



BATTERY POWERED WHEEL CRANE

MODEL

URW295WBE SERIES
URW095WBE SERIES

OPERATION & MAINTENANCE MANUAL

FURUKAWA UNIC CORPORATION

HEAD OFFICE : Nihonbashi nishikawa Bldg, 5-3, Nihonbashi
1-chome, Chuo-ku, Tokyo 103-0027, Japan



INTRODUCTION

Request to those who operate the crane

The operator's manual describes correct operation methods, simple inspection, and service for the UNIC crane.

Be sure to read this manual carefully to carry out correct and safe operation of the crane. Operate the crane after you have understood the contents of this manual.

Although we take all possible measures to ensure quality of the crane, you are requested to contact our business offices, UNIC sales agents, or authorized service stations whenever you have anything you do not understand.

◆ For making inquiries

When making inquiries, ordering spare parts, and requesting repairs, be sure to inform us of the crane model, specification, serial number, and cord number which are indicated on the name plate.

◆ Name plate of the machine is located at the rear side of column.

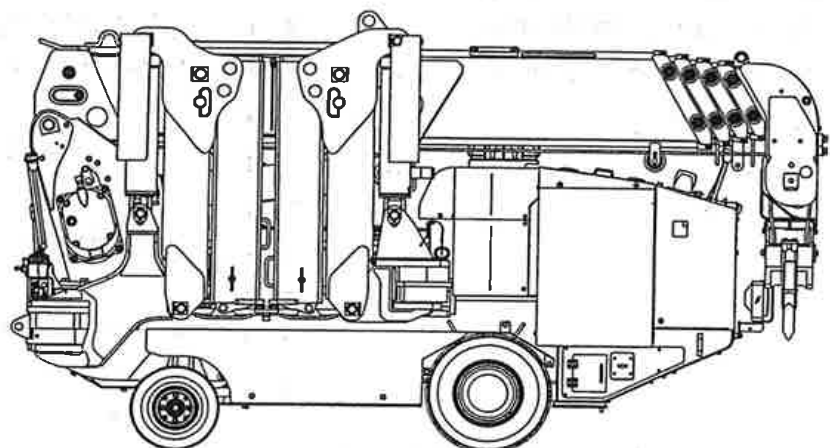
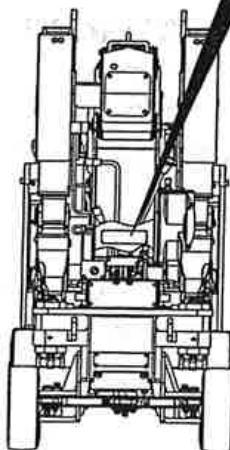
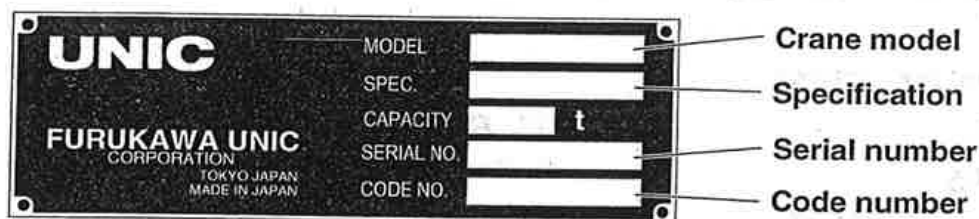



TABLE OF CONTENTS

13. U-WAVE, RADIO REMOTE CONTROL DEVICE

- ① Request to those who operate the crane 13- 1
- ② Safety precautions 13- 2
- ③ Designation of each equipment 13- 5
- ④ Inspection before crane operation 13- 8
- ⑤ How to switch crane operation mode 13-10
- ⑥ How to operate the crane through radio control operation 13-12
- ⑦ How to replace batteries of transmitter 13-34
- ⑧ Daily checks, trouble inspection 13-37
- ⑨ Mode indicator lamp (Control box) 13-43
- ⑩ Measures to be taken in an emergency..... 13-49

14. MAINTENANCE AND INSPECTION OF CARRIER

- ① Inspection before operation 14- 2
- ② Inspection and Maintenance which is to be carried out every 250 hours or 3 months 14- 9
- ③ Storage 14-10
- ④ Fitting safety covers 14-11

15. MAINTENANCE AND INSPECTION OF CRANE

- ① Inspection before operation 15- 2
- ② Cleaning 15- 3
- ③ Inspection of bolts mounting slewing bearings 15- 3
- ④ Replacement of wire rope (for winding-up)... 15- 4
- ⑤ Replacement of expendable parts 15- 8

16. LUBRICATION TO CARRIER

- ① Precaution when carrying out lubrication 16- 1
- ② List of recommended lubricant 16- 2
- ③ Filling oil and lubrication chart 16- 3

17. LUBRICATION TO CRANE

- ① Precaution when carrying out lubrication..... 17- 1
- ② List of recommended lubricant 17- 2
- ③ Lubrication chart 17- 3
- ④ Lubrication 17- 4

18. MAJOR SPECIFICATIONS

- ① URW295WEB (5-section boom) 18- 1
- ② URW095WBE (5-section boom) 18- 6
- ③ Major specification (Radio remote control device) 18-11



SETUP OF THIS MANUAL

SETUP OF THIS MANUAL

Crane covered in this manual have some difference in operation in accordance with the specifications of with or without radio remote controller.

Difference in operation due to crane specifications is separately illustrated in this manual for each specification.

Refer to separate "Instruction manual of radio controller" for operation and/or maintenance of the radio remote controller.

1. Designation of specification

Crane specifications covered in this manual are roughly divided into two, namely the standard and the moment limiter.

And each specification is sub-divided into two: crane with or without radio remote controller.

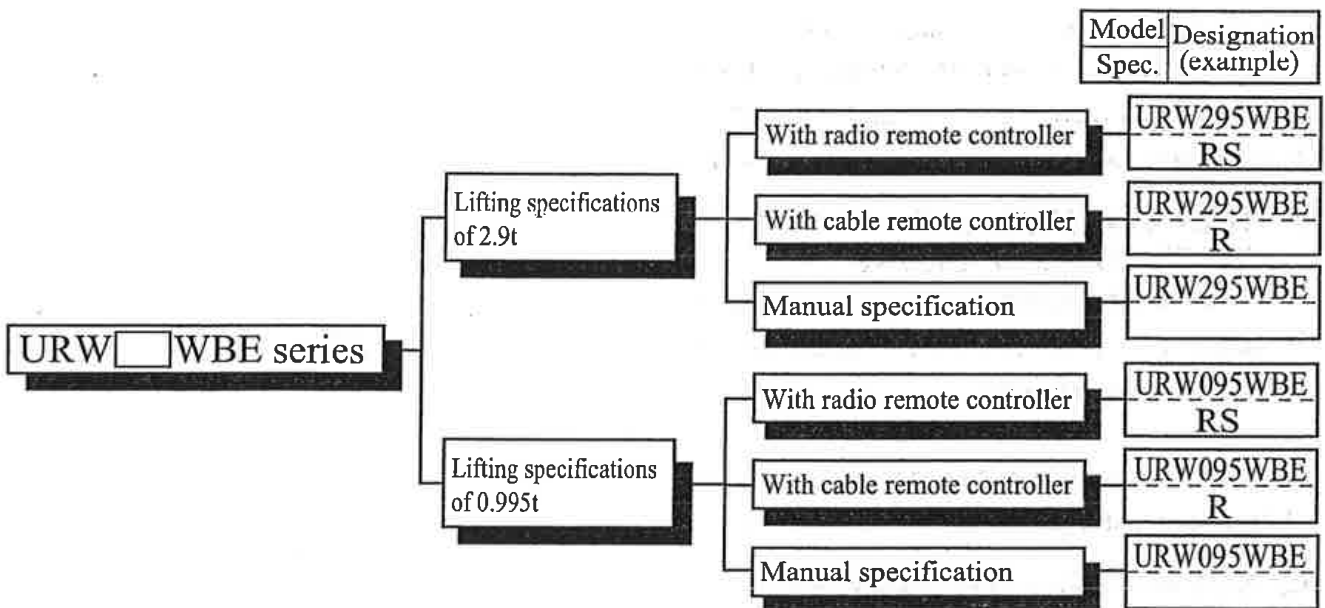

1. FOR SAFETY OPERATION

Observe all the safety regulations !



★ Read preventive measures against danger and cautions stated in this manual for proper understanding.

★ Most accidents related to the crane occur due to operation, maintenance, and inspection which have failed in observing basic safety regulations.

1 Request to customers

- ◆ Never failed to observe **⚠ WARNING** and **⚠ CAUTION** described in the manual as they are of great importance in safety and the crane operation.

⚠ WARNING ... Failure to observe this may invite an accident resulting in injury or death.

⚠ CAUTION ... Failure to observe this may cause damage to the crane.

- ◆ Store this manual where it is easily accessible to read it over and over again.
- ◆ Failure to observe the right operation and maintenance/inspection illustrated in this manual may cause trouble in the crane and may invite an accident, and this will not only shorten its service life but will impair safety in the crane operation. Please remember, in such cases, that no warranty will be given even if the crane is within valid warranty period.
- ◆ In order to prevent injury or death to crane operators and to those who stand close to crane operating area due to operational mistake, caution plates are stuck on the crane. You are requested to read them carefully.
- ◆ Do not alter the crane.
 - ★ If you want to make an alteration, contact with UNIC sales agent or an authorized service shop.
 - ★ UNIC does not bear any responsibility for troubles and/or accidents due to unauthorized alteration.

2. SAFETY PRECAUTIONS ON CARRIER OPERATION

! WARNING

★ Observe the cautions for securing safety.
Failure to observe the cautions may invite trouble or serious accident.

1 Before operation

1 Dress neatly and wear protectors such as helmet, safety shoes, and gloves without fail.

★ Do not wear baggy clothes and accessories which can be caught by control levers and fittings, and oil-stained working clothes which may catch fire.

2 Be sure to make inspection before operation and periodical voluntary inspection.

If found something wrong, repair it immediately.

3 The crane is prohibited to travel on a public road by the road traffic law.

4 Check that no safety covers have been left removed.

★ It is very dangerous to start the motor, to operate the crane with the safety cover removed as the driving mechanism is directly exposed.

5 Be sure to stop the motor before changing or supplying and changing lubricant.

A fire source such as smoking cigarette in mouth is strictly prohibited.

Failure to observe this may cause a fire.

6 Shift the crane-travel lever to "Travel" when traveling the crane

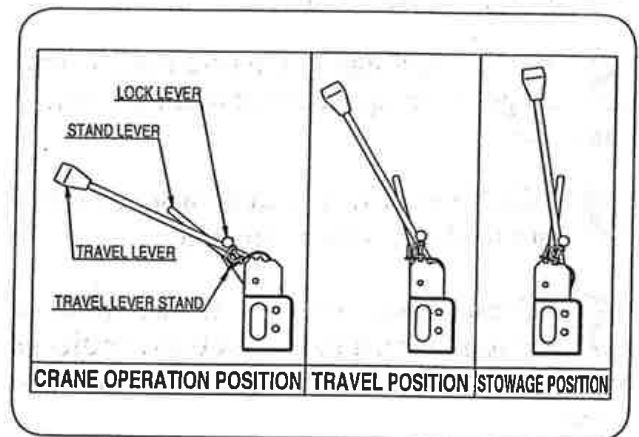

★ Crane will not work unless the crane-travel lever is shifted to "Crane" position.



SAFETY PRECAUTIONS ON CARRIER OPERATION

2 During Operation

1 This carrier is equipped with especially small mounting platform of narrow width for its size in order to be able to work in narrow spaces. A crane of high capability is mounted on the platform therefore, the position of the gravitational centre is high.

★ Pay special attention to the carrier in order to prevent roll-over when travelling.

2 Keep away from the periphery of the carrier for more than 2 m other than operators when travelling.

3 When travelling, make sure that the outrigger is being retracted and then retract the hook.

4 Never travel with lifted cargo or without the boom being retracted.

5 When abrupt turning is involved or travelling on a road of a bad condition, make sure to reduce the speed with utmost care.

6 When driven over an irregular road surface or going up and down the slopes, the carrier must get over the slope straight and try not to give any shocks to it.

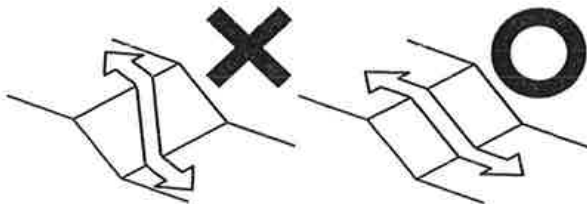

7 When the carrier gets over a gap of the step of 15 cm or more, always use scaffold boards.

8 Pay special attention to the surroundings when travelling.

9 If you have to park the carrier on a slope, make sure to block the wheels.

10 Make sure to travel at low speed on a slope. Avoid abrupt starts and stops as well as sudden route changes as it may cause slipping depending on the road condition.

11 When you drive up and down the slope, always operate at the upper side of the carrier.

12 Do not operate the carrier on the more steep slope than shows below, as there is a risk of roll-over. Refer to the chapter "3 Straight traveling on the steep slopes and upload/unload the carrier" for the details.

Move forwards and backwards (straight)

Left/Right gradients

Less than 5°
on the unstable road

Less than 10°

Drive over a gap of the step with either left or right side of the carrier

Less than 40 mm Less than 5°

When driving over a gap of the step, there is a risk of tipping over caused by vibration or a shock. Therefore, make sure the gradient of carrier is less than 5°, or the gap of the step is less than 40 mm. The driving speed should be "Very Low Speed" and sudden turning is strictly prohibited.

13 Never travel on the bedrock or sharp stones.

SAFETY PRECAUTIONS ON CARRIER OPERATION

Travelling on bumpy roads or sharp stones such as stony roads at a riverbed, solid rocks with deep concaves and convexes, macadamized ground, iron plate edges or, on the reinforcing bars, iron scraps, scrap materials will suffer a wear and a much shorter life than can usually be expected.

14 Never travel with materials or animals on the carrier.

★ There is a risk of injury in case of an abrupt turning or shift of gravity.

15 Do not park the carrier on the flammable materials such as grass or straws.

★ Combustible materials might be ignited by electric spark, etc. and can cause fire.

3 ***Straight traveling on the steep slopes and upload/unload the carrier***

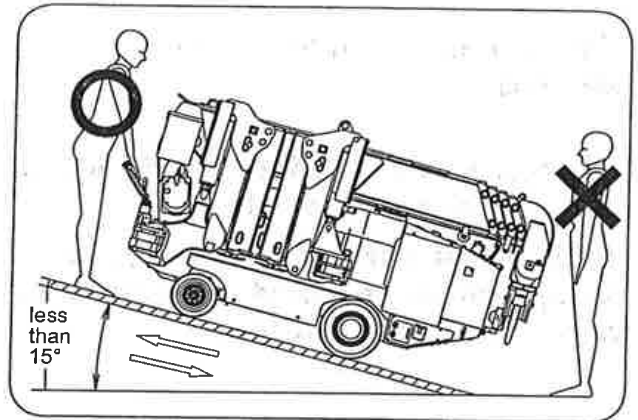

1 If you have no alternative but to drive up a steep slope or load/unload the carrier on the steep slope from the truck, make sure that the gradient is less than 15°, the road surface is stable and not slippery, and the scaffold board is securely installed.

Use the scaffold boards which satisfy the requirements of strength, width and length.

★ When driving up a steep slope, the operator must stand at the upper side of the carrier as it might slip off depending on the road condition.

★ The driving speed should be “Very Low Speed” and a turning movement is strictly prohibited.

★ Never stand at the lower side of the carrier.

★ When the carrier is going to slip off, never support it with human hands.

2 Stop the engine, apply the parking brake, and block the wheels of the truck.

★ Otherwise, the truck can start to roll when loading/unloading the carrier resulting a fall accident.

SAFETY PRECAUTIONS ON CARRIER OPERATION

4 After operation

1 Return the travel lever and run the motor at a low speed.

2 Shift the travel lever to "Crane" position.

3 Stop the motor and remove dirt and dust stuck on the crane body.

★ Since dust stuck on the battery, electric wiring, and motor related components may cause a fire, be sure to remove it.

4 Cover the crane or store it in a storage house to prevent it from being accessed by unrelated persons such as children.

★ Cover the crane after heated sections have been cooled off.

Putting a cover on while the crane body is still hot may cause a fire.

5 Remove the starter switch key to keep it securely.

6 Disconnect a battery connector before the crane is to be stored for a long period of time.

★ Failure to disconnect it may cause a fire as cables short-circuited by gnawing animals such as rat.

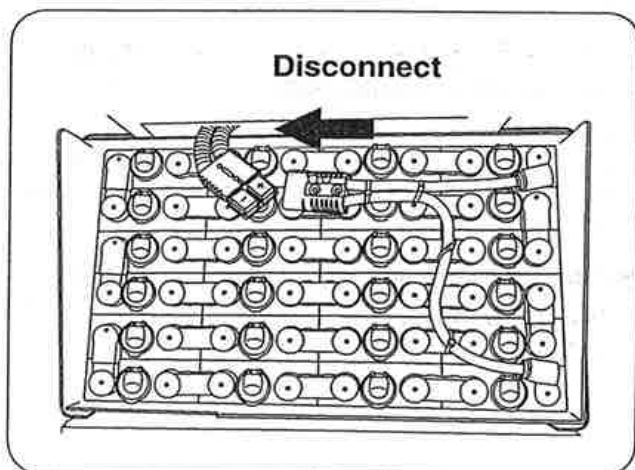



3. SAFETY PRECAUTIONS ON CRANE OPERATION

1 Before operation

1 Be sure to make inspection before operation and periodical inspection for slinging implements.

★ If a defective slinging implement is used, fall of lifted cargo may result.

2 Shift the travel lever to "Crane" position.

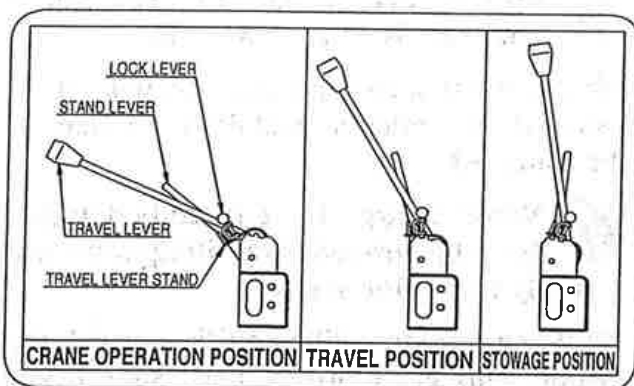

3 Turn ON the overwinding alarm switch.

4 Make sure that each safety device is always functioning properly.

★ Be sure to turn ON the overwinding alarm switch before starting crane operation.

5 Keep a safety distance away from the high-voltage power line to avoid an electric shock.

★ The crane is not electrically insulated.

6 Do not operate the crane when wind velocity exceeds 10m/sec. and/or while thundering.

★ Crane operation while strong wind is blowing can cause fall of a lifted cargo or overturn of the crane as the boom and/or a lifted cargo are hit by a gust of wind.

7 Pay attention that anyone except persons concerned will not enter within a working radius of the crane.

★ Take good care to carry out safety operation by keeping a close watch around the working area.

8 Make sure that the ground on which outriggers are to be set up is solid and firm.

★ When setting up the outriggers on an unlevelled ground or on a slope, be sure to place a support (such as plank, steel plate etc.) under the outrigger foot flanges to keep the crane level.

In addition, when the crane is to be operated on a soft ground, take the same measures to prevent the outrigger foot flanges from sinking into the ground when a cargo is lifted up.

9 Lift up the wheel by approx. 50mm from the ground.



10 Operation with the crane kept leaning makes it unstable when a cargo is lifted up.

Such operation can cause the crane to be overturned.

11 In normal crane operation, be sure to set up the crane level with the outriggers fully extended.

12 Do not stand under or in front of the hook when unhooking as it swings.

13 Do not try adjusting hydraulic equipment.

14 If the crane is equipped with the turnover prevention device, confirm that the crane makes an automatic stop when overloaded.



SAFETY PRECAUTIONS ON CRANE OPERATION

2 During operation

1 Pay attention that the hook will not be overwound.

Be sure to turn ON the "over-winding alarm switch".

★ Remember that the hook is wound up when boom is extending.

★ If the hook hits against the boom top due to being over-wound of the hook, it may cause damage to wire rope and the sheaves at the boom top and may cause the fall of lifted cargo.

2 Operate each lever slowly and smoothly.

★ An abrupt lever operation with a cargo lifted gives an excessive shock to the crane which may cause damage to the crane and/or overturn due to swing of a lifted cargo.

★ If a control lever will not make a smooth return to its neutral position, carry out lubrication and repair as soon as possible.

3 Slew the crane at low speed.

★ Swing of a lifted cargo increases working radius of the crane which may cause it to be overloaded.

4 Overloaded operation is strictly prohibited.

★ Crane operation with a load exceeding the rated load hoisted may cause damage or overturn to the crane.

★ For the crane equipped with turnover prevention device (be sure to check if it is mounted):

Do not put too much confidence on the device even if the crane is equipped with the device with warning and automatic stop.

It functions just as an auxiliary device.

It is the principle that you should persistently observe the operation within rated load.

If an alarm sounds due to decrease of ground reaction, lower the operating speed immediately to shift the crane to safer side.

★ If ground reaction decreases further, the crane stops following functions automatically when you should pay special attention to the crane because it may roll over due to swing of a lifted cargo.

⊙ Winding-up hook ⊙ extension of boom
⊙ lowering boom ⊙ Slewing

5 Pulling a cargo sideways, straight, or obliquely is strictly prohibited.

★ These operation may cause slewing members, booms, columns, and derrick cylinder to be damaged.

6 When a cargo to be lifted is detached from the ground, stop lifting it up temporarily to confirm safety.

★ When a cargo is lifted off the ground, stop lifting it up temporarily to make sure that the cargo is kept horizontally, the crane maintains its stability, and the rope slinging up the cargo is positioned properly.

Then lift it up again after making sure of the safety.

★ For lowering a cargo, stop lowering it immediately before it touches the ground then lower it again gradually.

7 Do not leave from operating position with a cargo hoisted.

★ Lower a hoisted cargo onto the ground before leaving the operation site.

8 Do not get up on a cargo being hoisted.

★ This may cause a fall from the cargo being hoisted.

9 Do not stay under a hoisted cargo.



SAFETY PRECAUTIONS ON CRANE OPERATION

10 Pay attention that wire ropes will not be paid out unnecessarily to prevent ropes from being wound around the drum irregularly

★ Operation such as paying out wire ropes further with a cargo placed on the ground, retraction and/or lowering boom which loosen the ropes to cause them irregular winding which results in remarkable shortening service life of the ropes.

★ Wind the first layer of rope firmly and regularly around the drum.

★ Correct kinks of rope immediately with a mallet.

11 Pay extra attention to underground crane work in which the hook must be lowered further than the work on the ground.

★ When paying out wire ropes, be sure that more than 3 turns of rope must always be left on the drum.

12 Stop the crane operation when temperature of hydraulic oil exceeds 80°C.

★ Oil temperature is apt to rise easily if repeated operation of winding up and down the hook, especially in a high lift, is required.

★ Excessive high temperature of hydraulic oil damages high-pressure hoses and gaskets being employed to cause the oil to spout out so that a scald may result.

13 Do not touch the motor, pump and the hood in the side with a bare finger as they become too hot.

3 After operation

1 Make sure that the booms, the outriggers, and the hook have been stored before traveling the crane.

2 Do not carry out maintenance and inspection while temperature of either hydraulic oil or gear oil is still high.

★ Temperature of both hydraulic and gear oil is high immediately after crane operation so that accumulated high pressure still remains. Removing filling cap, draining oil, or replacing oil filter while temperature is still high allows hydraulic and/or gear oil to spout out and a scald may result.

3 Since temperature on the motor, inverter, pumps and the hood in the side is too high immediately after crane work, touch them after they have been cooled down.

4. DESCRIPTION OF CARRIER EQUIPMENT

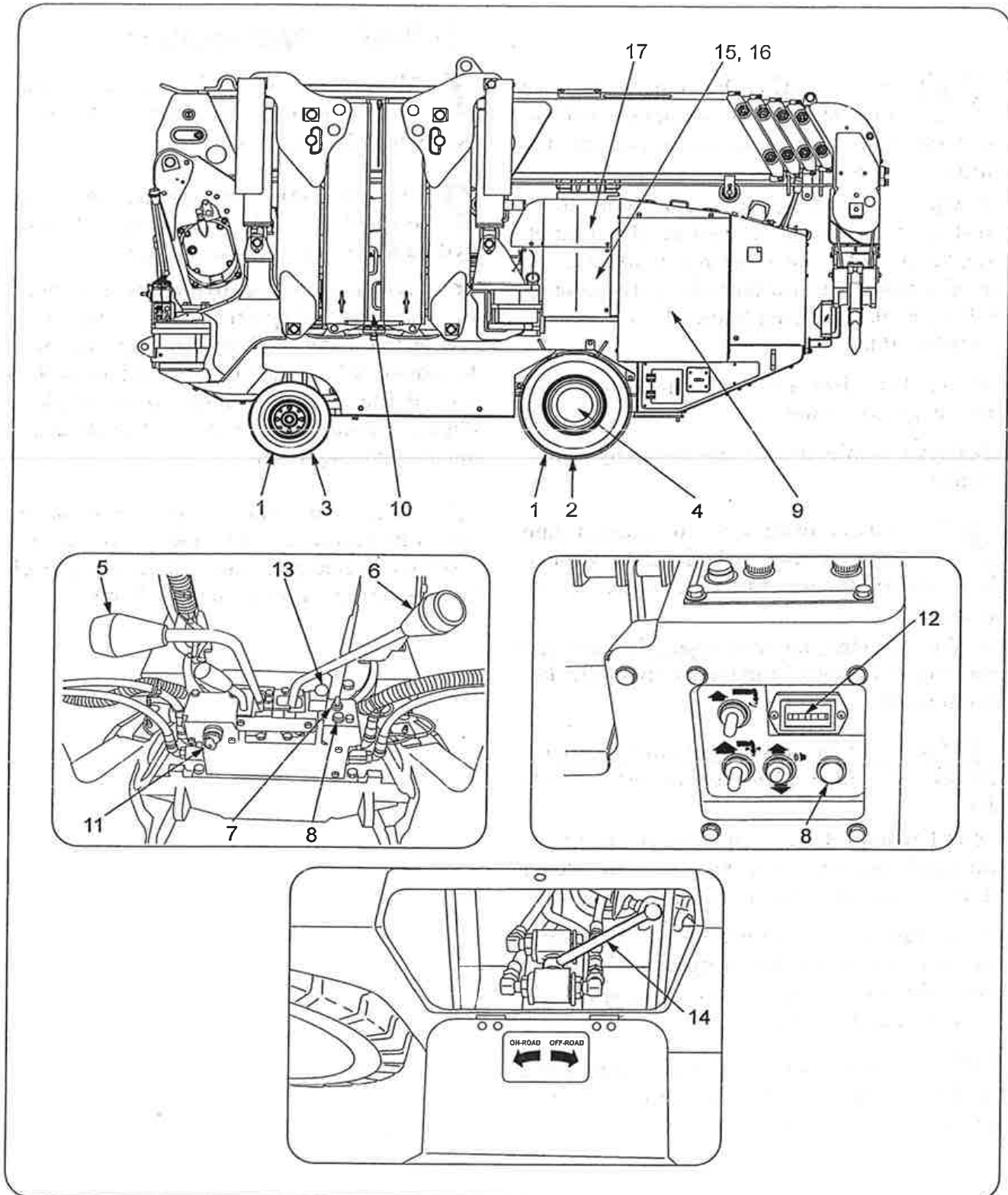

*DESCRIPTION OF CARRIER EQUIPMENT*

- 1. Solid rubber tire**
- 2. Drive wheel**
Power transmission from the motor
- 3. Steering wheel**
Direction switch in the steering linkage
- 4. Traveling motor**
Hydraulic motor with reduction gears which transmits driving power to the wheel tire is built inside.
- 5. Travel lever**
This is to change traveling speed and traveling forward.(backward)
- 6. Steering lever**
This is to change direction.
- 7. Accelerator switch**
This is to control motor speed.
- 8. Horn switch**
- 9. Liquid type lead acid battery**
- 10. Hydraulic oil tank**
This is filled with hydraulic oil which commonly supplies both to the carrier and to the crane.
- 11. Starter switch**
This is a switch to start and stop the motor.
- 12. Hour meter**
This indicates total motor running time.
- 13. Lock lever**
- 14. Travel mode select lever**
This is to change the traveling mode on road/off road.
- 15. Motor**
- 16. Inverter**
- 17. Charger**

5. DESCRIPTION OF CRANE EQUIPMENT

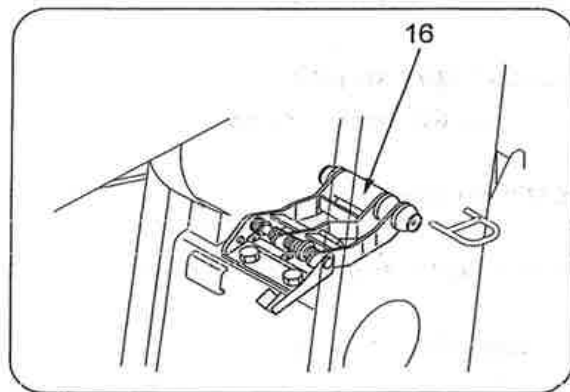
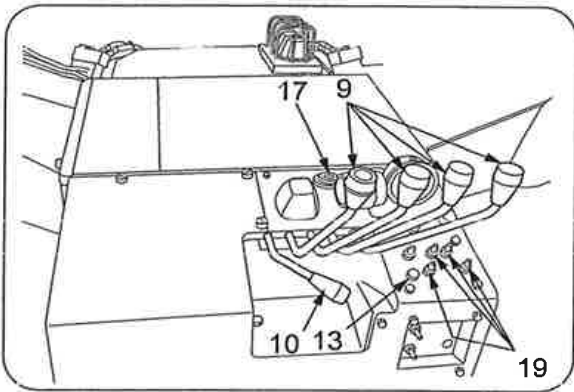
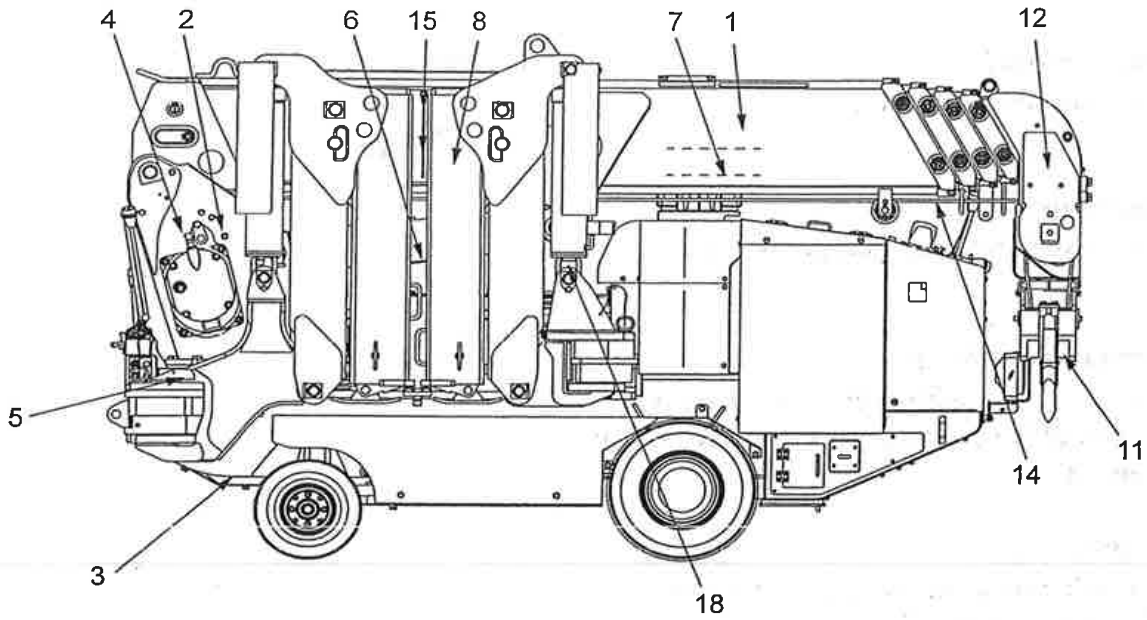



DESCRIPTION OF CRANE EQUIPMENT

1. Boom

It extends and retracts by hydraulic cylinder and the hook is suspended from its top.

2. Column

This is a vertically mounted member on the crane in which boom, winch, and derrick cylinders are installed.

The column can be turned by slewing device.

3. Frame

This is fixed on the vehicle to support the column and outriggers.

4. Hoist winch

This is a device which rotates the wire drum by hydraulic motor to hoist up and down a cargo via wire ropes.

5. Slewing device

This turns the column by hydraulic motor.

6. Derrick cylinder

This raises and lowers the boom.

7. Telescoping cylinder

This extends and retracts sections of boom.

8. Outrigger

This supports the crane to maintain its stability while it is operated.

9. Crane operating levers

Respective levers control raising and lowering boom, hoisting a cargo up and down, telescoping boom, and slewing boom.

10. Outrigger control levers

Respective levers control raising/lowering and extending/retracting outriggers.

11. Hook

12. Overwinding alarm

When the hook comes close to the boom top, this makes an alarm to warn that wire ropes are to be over-wound.

13. Warning horn

Depression of warning switch sounds the horn for warning.

This is to warn co-workers and others in the operation site.

14. Wire rope

15. Load indicator

This can read the rated load value corresponding to extended length of the boom and its raised angle.

16. Automatic stop for leaving minimum wire rope (with wire rope retaining roller)

This is a device to restrict slackening of wire rope on the drum which allows to stop unwinding automatically when remaining wire rope on the drum comes close to 3 turns.

17. Level

This is an instrument for checking horizontal plane of the crane body.

18. Turnover prevention device (only crane equipped with device)

This detects load against ground from outriggers.

19. Outrigger selection switch

This selects active outrigger and operating direction.



MEMO



A series of horizontal lines for writing, starting with a solid line and followed by a dashed line, repeating down the page.



6. NAME PLATES

1 Description of name plates (Stickers)

The machine is provided with stickers indicating caution (framed in box) and specifications as shown in the figure below, and in addition to that there are stickers showing control levers, switches, and instructions for lubrication.

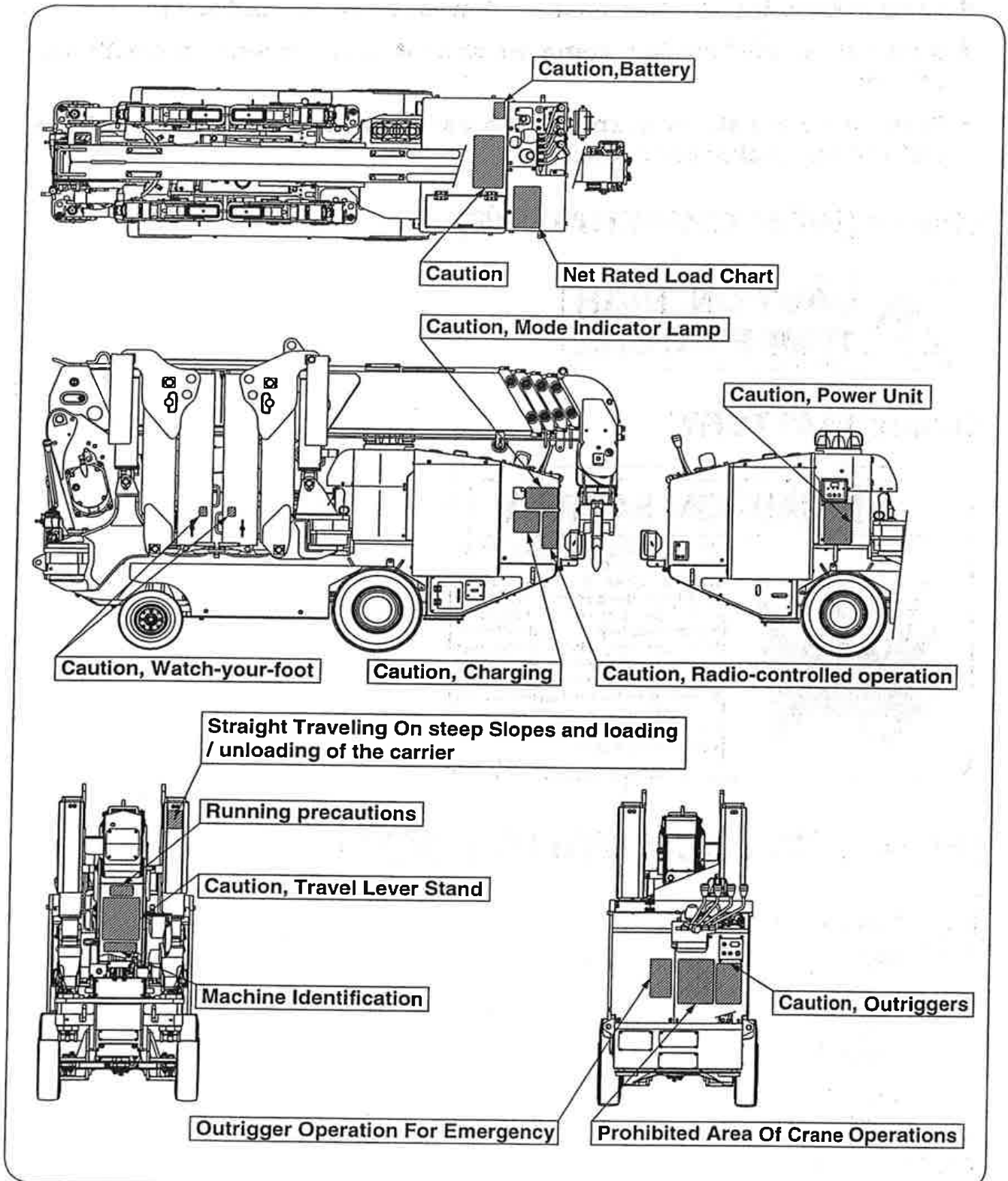



NAME PLATES

2 Stickers in detail



- ★ Always keep the stickers clean so that they can be read easily.
- ★ If any of the stickers has come off, stick it again or replace it with new sticker.
- ★ When ordering stickers, specify the part number shown at the bottom-right of the sticker concerned.

Sticker [HIGH TEMPERATURE]



Sticker [BATTERY]



Sticker [WATCH-YOUR-FOOT]



Sticker [OUTRIGGERS]



CAUTION

OUTRIGGERS

- Place the crane on a firm and level surface and use the outriggers in principle in a fully extended condition.
- Do not extend the outrigger cylinders with the outriggers stowed.
- Swing the outriggers with the outrigger cylinders retracted.
- For extension of the outriggers, be sure to support the outriggers on the ground with the outrigger cylinders after the inner boxes are extended.
- For stowage of the outriggers, be sure to stow the inner boxes after the outriggers are fully retracted, and swing the outriggers to the stowage position after the outer boxes are folded.
- When extending and retracting the outriggers, be sure to insert swing lock pins to prevent the outriggers from swinging.
- When travelling, be sure to stow the outriggers.

FULLY EXTENDED CONDITION OF OUTRIGGERS

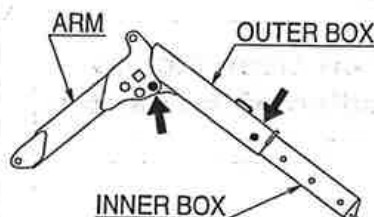
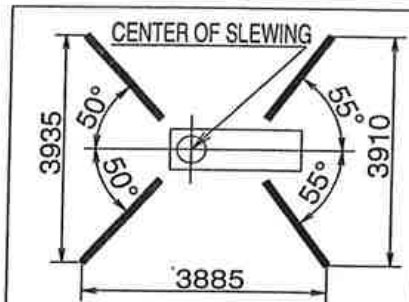

Condition in which the inner box is fully extended and the outer box securing pin is placed in the "fully extended" position.

- If either of the inner box or outer box is positioned at other than maximum extension, operate with performance of other than maximum extension.
- In case of swing with a load lifted, fore-and-aft stability of the main body is different from right-and-left stability. Shorten an operating radius as much as possible and perform operations using caution in turnover.
- When operating the crane, be sure to keep the crane level using the outriggers.
- If placement of each outrigger is changed from the above illustration, operate according to a different plate "Prohibited area of crane operation."

09R886080-W295CR

NAME PLATES

Sticker [Running precautions]

⚠ Running precautions

Move forwards and backwards(straight)

Always operate at the upper side of the carrier

Left/right gradients

Less than 5° on a stable road

Less than 10°

■ Travel at low speeds near the shoulder of roads and on hills, and avoid abrupt starts and stops as well as sharp turns as it may cause the carrier to slip.

Slope of step(lateral)

Less than 5°

Less or than 40mm

■ On a slope of a step, the carrier may roll over due to recoil so operate it as shown in the illustration and at a very low speed.

30F486310-W095WBE

Sticker [Straight traveling on steep slopes and loading/unloading of the carrier]

⚠ Straight traveling on steep slopes and loading/unloading of the carrier

Less than 15°

- If you have no choice but to drive up a steep slope or load/unload the carrier on a steep slope using removable ramps from a truck, make sure that the gradient is less than 15°, the road surface is not slippery, and the scaffold board is securely installed. Use scaffold boards of sufficient strength, width and length.
- When driving up a steep slope, the operator must always stand on the upper side of the carrier and must never stand below it in case it slips.
- The carrier should be driven at a very low and turning is strictly prohibited.
- When it appears that the carrier is slipping, never prop it up with a worker.

30F486290-W095WBE



NAME PLATES

Sticker [CAUTION]

⚠ CAUTION

- Read the instruction manual carefully before use.
- When operating this crane, check the surrounding area for safety.
- Be sure to perform inspection and maintenance before starting operation.
- Be sure to stop power (battery, power source) before inspection and maintenance.
- Be sure to reinstall covers removed for inspection and maintenance.
- Place the crane level using a level.
- A load indicator shows performance of the crane placed on a firm and level surface.
Never perform overload operation by combined use with a load meter.
- If hoisting the load exceeding the rated load, the crane may turn over. Observe the rated load for operation.
- Never allow travel with a load lifted and crane operation with no outriggers extended.
Doing so is very dangerous.
- Extend the outriggers and float the carriage by approx. 50 mm for crane operations.
The carriage, if not floated, may be damaged. Never perform operations with the carriage floated high, which is very dangerous.
- High-speed slewing may cause the crane to turn over by slewing of load.
Slewing at such a speed as does not cause slewing of load.
- When extending the boom, allow room between the boom top and the hook.
- The weight of a lifted load can be measured with a load meter only during hoisting of the hook. Adjust the motor speed so that the needle points to 0 while operating hoist work under no load and measure the weight of the lifted load at the motor speed.
- When travelling, be sure to store the hook completely.
- After completing the work, be sure to turn OFF the key switch.

WORKING RANGE CHART

WORKING RADIUS (m)

Note: The chart shows the data when the crane is operated with no-load and shift due to deflection of boom is not considered.

⚠ CAUTION SLEWING BOOM

30F466070-URW095WBE



NAME PLATES

Sticker [NET RATED LOAD CHART](Example for URW295WBE)

NET RATED LOAD CHART		Net rated load is the lifting capacities excepted for the mass of the hook.											
BOOM SECTION		1		1+2									
WORKING RADIUS(m)		1.0	1.4	1.5	1.8	2.0	2.5	3.0	3.5	3.835	<p>CAUTION NET RATED LOAD</p> <ul style="list-style-type: none"> The net rated load is performance when the crane is placed level and is based on an actual working radius including boom deflection under load. The net rated load is also based on strength and stability of the crane. Maximum extension of an outrigger is a condition in which the inner box is extended to the maximum extension position and a swing lock pin of the outrigger arm is inserted into the normal position. In other conditions than the above, operate with performance of not maximum extension. If any one of the four outriggers is not fully extended, operate with performance of not maximum extension. Improper set-up of the outriggers may cause the crane to turn over. Place the outriggers on a firm and level surface with maximum extension. Make sure, then that lock pins are securely inserted. The boom [1+2+3+4] is a condition in which the boom [4] is extended to the mark. Operate with performance of [1+2+3] when the boom [3] is extended even if only a little, performance of [1+2+3+4] when the boom [4] is extended even if only a little; and performance of [1+2+3+4+5] when the mark on the side plate of the boom [4] moves away from the boom [3] even if only a little. 		
NET RATED	OUTRIGGER MAX EXT.	2.9	2.9	2.65	2.25	2.05	1.65	1.3	1.0	0.9			
LOAD(t)	OUTRIGGER NOT MAX EXT.	2.0	2.0	2.0	1.45	1.1	0.65	0.49	0.35	0.25			
BOOM SECTION		1+2+3											
WORKING RADIUS(m)		2.2	2.5	2.9	3.0	3.5	4.0	4.5	5.0	5.37			
NET RATED	OUTRIGGER MAX EXT.	1.35	1.35	1.35	1.25	1.0	0.8	0.65	0.52	0.43			
LOAD(t)	OUTRIGGER NOT MAX EXT.	0.8	0.65	0.53	0.5	0.38	0.28	0.22	0.16	0.12			
BOOM SECTION		1+2+3+4											
WORKING RADIUS(m)		3.4	3.8	4.0	4.5	5.0	5.5	6.0	6.5	6.89			
NET RATED	OUTRIGGER MAX EXT.	0.85	0.85	0.75	0.6	0.5	0.42	0.36	0.32	0.27			
LOAD(t)	OUTRIGGER NOT MAX EXT.	0.42	0.34	0.3	0.25	0.19	0.14	0.1	0.08	0.06			
BOOM SECTION		1+2+3+4+5											
WORKING RADIUS(m)		3.8	4.1	4.5	5.0	5.5	6.0	6.5	7.0	8.0	8.41		
NET RATED	OUTRIGGER MAX EXT.	0.55	0.55	0.45	0.37	0.31	0.27	0.23	0.2	0.15	0.13		
LOAD(t)	OUTRIGGER NOT MAX EXT.	0.35	0.29	0.25	0.2	0.16	0.13	0.1	0.07	0.04	0.03		

30D786050-W295CP2E

Sticker [MODE INDICATION LAMP]

CAUTION		MODE INDICATOR LAMP	
INDICATOR (LIT)	OPERATION MODE (STATUS)	RADIO CONTROL SELECTOR SWITCH	POSSIBLE OPERATION
00	CRANE MODE	RADIO CONTROL ON	MANUAL AND RADIO CONTROL
01		RADIO CONTROL OFF	MANUAL
04	OUTRIGGER RADIO CONTROLLED MODE	RADIO CONTROL ON	MANUAL AND RADIO CONTROL
05		RADIO CONTROL OFF	RADIO CONTROL
10	OVERWINDING	---	---
13	STORAGE OF HOOK	---	---
14	CANCELLATION OF AUTO-STOP	---	---
15	AUTOMATIC STOP	---	---
0F	TRAVEL MODE	---	---

- The above table shows the main mode indication. For details, see the instructions.
- The radio control selector switch opposite to the mode indicator lamp allows selection of ON and OFF of radio-controlled operation.
- When radio control is ON, both manual and radio-controlled operation can be performed.
- When radio control is OFF, radio-controlled operation cannot be performed (except for outrigger radio-controlled operation).
- Flashing of the mode indicator shows abnormality of operation or the equipment. Follow instructions of the instruction manual.

09R886160-W295CR



Sticker [OUTRIGGER OPERATION FOR EMERGENCY]

⚠ OUTRIGGER OPERATION FOR EMERGENCY

When the outriggers do not operate normally with normal operation methods, operate them in a make-shift manner in the following procedures. When the specific work is complete, have the outriggers inspected and repaired at your nearest service shop of our products as soon as possible.

1. Remove this cover of the outrigger valves.
2. Push the solenoid valve button of the following outriggers to be operated with a narrow rod such as a screwdriver.
3. Operate the outrigger control lever while pushing the solenoid valve button.

OPERATION	OPERATION METHOD	
OUTRIGGER ①	RET.	Push 1 and operate the lever.
	EXT.	Push 2 and operate the lever.
OUTRIGGER ②	RET.	Push 5 and operate the lever.
	EXT.	Push 6 and operate the lever.
OUTRIGGER ③	RET.	Push 7 and operate the lever.
	EXT.	Push 8 and operate the lever.
OUTRIGGER ④	RET.	Push 3 and operate the lever.
	EXT.	Push 4 and operate the lever.

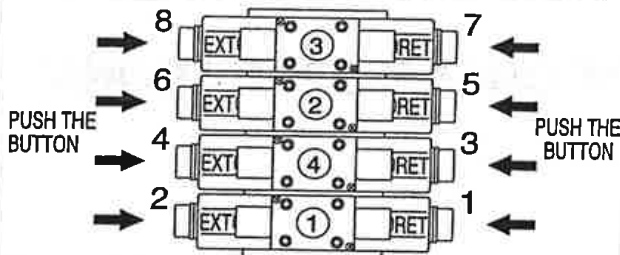

VALVES FOR OPERATING OUTRIGGERS

Note: When removing the cover or pushing the solenoid valve switch, be careful not to damage the wiring.

09R886190-W295CR

Sticker [Radio-controlled operation]

⚠ CAUTION Radio-controlled operation

- For approx. two seconds after the key is switched ON, the system is analyzed. Do not operate the crane during this period. If the crane is operated during system analysis, a voice urging "inspection and maintenance" is announced. In this case, switch the key ON again.
- When the emergency stop switch in the switch panel is turned to "STOP", all crane movements make an emergency stop.
- If the crane does not operate in spite of an announced voice saying "Remote control ready." after the key is switched ON, it is possible that the emergency stop switch is turned to "STOP." In this case, the crane can be operated if the emergency stop switch is turned to "RESET."
- Be careful that in case of performing hook storage operation with the switch panel of the crane, the manual operating lever also moves with the switch turned to "STORE."
- Be careful that in case of operating the crane with a radio control transmitter, the manual operating lever moves simultaneously.
- If the manual operating lever is moved during radio-controlled operation, the crane stops automatically.
- Operation with a radio control transmitter cannot be performed during crane operation with the manual lever.

09R886150-W295CR



NAME PLATES

Sticker [TRAVEL LEVER STAND]

CAUTION TRAVEL LEVER STAND

CRANE OPERATION POSITION	TRAVEL POSITION	STOWAGE POSITION
--------------------------	-----------------	------------------

- When changing the position of the travel lever stand, be sure to change the position by holding the stand lever instead of the travel lever.

CRANE OPERATION POSITION

- When operating a crane, pull up the lock lever and tilt the travel lever stand toward you.
- Tilt the travel lever stand until it contacts the stopper. If the crane is operated without the travel lever stand tilted to the end, the travel lever may contact the main body of the crane while the crane is swung, resulting in breakage.
- Be careful not to contact the travel lever while operating the crane. The contact activates the wheel, which is dangerous.

TRAVEL POSITION

- When travelling, set the travel lever stand to the travel position. Be sure to secure the stand with the lock lever.
- When the travel lever stand is set to the travel position, the crane does not operate at all except for travelling.
- When changing to the travel position, be sure to slow the boom and outriggers and position the crane to the travel position. Travelling without positioning the crane to the travel position may cause a serious accident such as turnover.

STOWAGE POSITION

- When transporting a crane, pull up the lock lever and tilt the travel lever stand toward the column.
- Even when the travel lever stand is in the stowage position, operation of the travel lever activates the carriage if the hydraulic pump operates. Use due care when changing the position.

30F48600-URW095WIDE

Sticker [PROHIBITED AREA OF CRANE OPERATIONS]

PROHIBITED AREA OF CRANE OPERATIONS

Orange areas in each outrigger placement shows prohibited areas of crane operations.

- Perform operations with outriggers extended in each illustration so that the position of a lifted load does not go beyond white areas.
- Never perform operations in orange areas, because the crane may turn over.
- Be sure to set any two adjacent outriggers of the four outriggers to normal extension (front 55 degrees, rear 50 degrees) as shown in the above illustrations. If any one of the four outriggers is not fully extended, operate with performance of not maximum extension.
- Be sure to insert the swing lock pins to prevent the outriggers from rotating.

05 18A0279-1025C01



NAME PLATES

Sticker [POWER UNIT]

	CAUTION	POWER UNIT
<ul style="list-style-type: none"> ■ Read the manual carefully before starting operation. ■ Immediately after the power is ON, battery level may not be displayed correctly. ■ Displays a warning when the battery level drops, the operating speed is reduced. ■ Power will automatically stop if don't operate 30 minutes. (Flashing SLP) Restart the power if used again. ■ Do not high-pressure washing. ■ The table below displays the main message. Please refer to the instruction manual for more information. ■ Operation mode select 		
Std	Standard	This is the normal mode of operation.
H I	High speed	This mode, power consumption will increase, but you can do the operation at high speed.
<ul style="list-style-type: none"> ■ Battery level warning 		
↓ ↓ ↓	Slowdown	The battery level became less than 10%.
End	Stop	Unit was stopped because the battery power was exhausted. Charge the battery. If you need to operation urgently, please press and hold for more than 5 seconds (reserve) button.
RES	Reserve mode (Significant slowdown)	This mode will provide the power needed to withdraw from the work site. Power supply is only a little time. Therefore please charge as soon as possible.
End.	Complete Stop	Unit was stopped because the battery power was completely exhausted. Charge the battery.
<ul style="list-style-type: none"> ■ Error message 		
E07	An error has occurred in the CAN-bus communication of the inverter. Please restart the power.	
E. 13	Emergency stop switch has been pressed. If you want to restart, please release the switch.	
E94	Crane has been in operation during the initial check. 3 seconds after start-up, please do not operate the crane. Please restart the power.	
E95	Voltage of the battery is too low. Turn off the power, please charge.	
30F486230-W095WBE		

Sticker [CHARGING]

	CAUTION	CHARGING
<ul style="list-style-type: none"> ■ Read the manual carefully before charging the battery. ■ Charge after OFF the power to the electric unit. ■ Hold the plug when disconnecting the plug, do not pull on the cord. ■ Disconnect the plug after OFF the power to the charger. ■ The charging time depends on the remaining battery power. ■ Don't place objects on the power cord. ■ The mode lamp of charger ■ The mode lamp of charger 		
	Charger LED	
Charger power off	Extinction	
Charging	Lighting(RED)	
80% charge	Lighting(YELLOW)	
100% charge	Lighting(GREEN)	
30F486240-W095WBE		



MEMO



A series of horizontal lines for writing, starting below the decorative line and extending to the bottom of the page.

7. DEFINITION OF TERMS

1 Extension and spread of outriggers

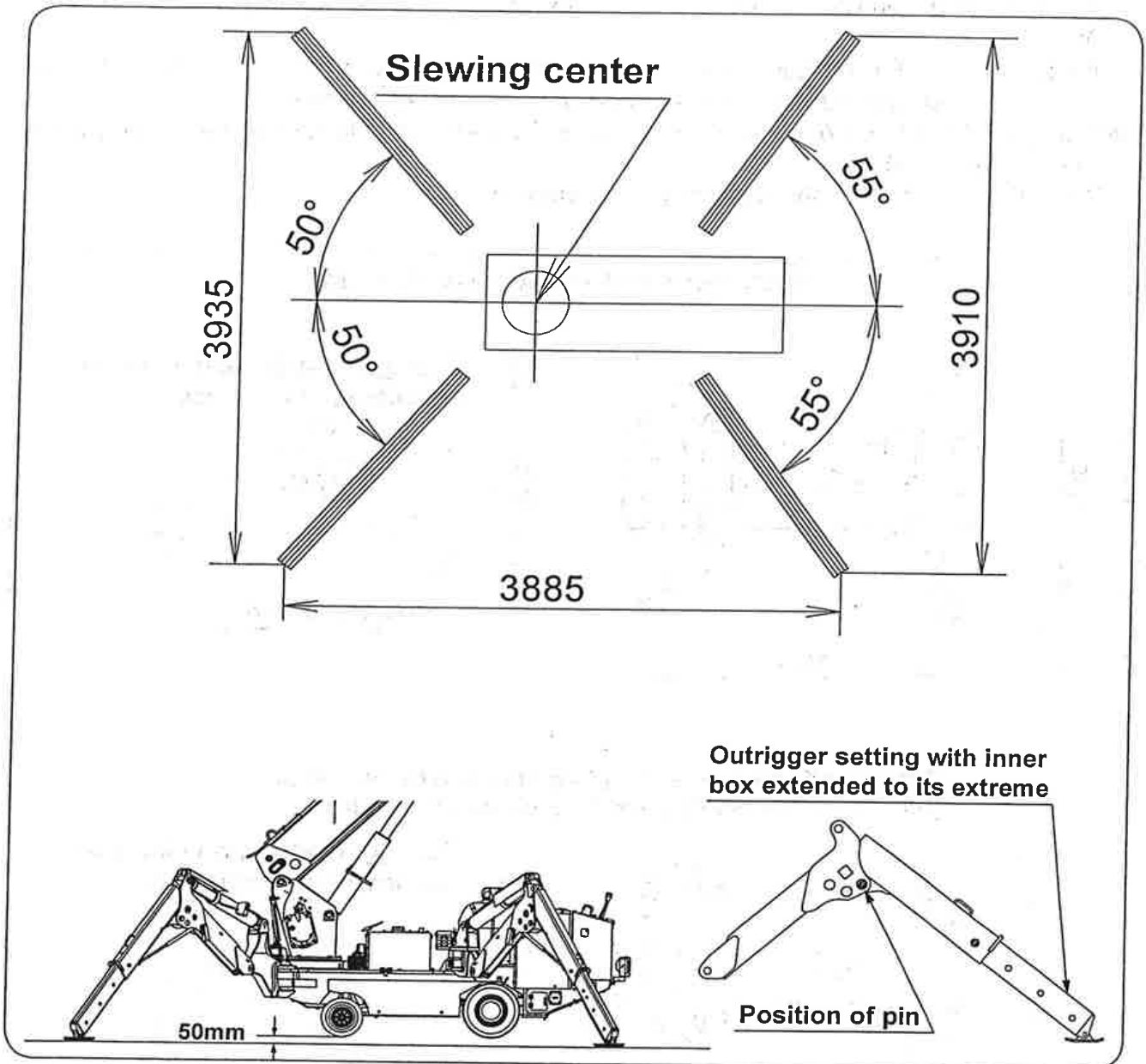

The figure above shows that outriggers are extended to their extremes. Carry out operation by making the crane level on a flat and solid ground with the outriggers extended to their extremes, and with the crane body raised by approx. 50mm above the ground.

DEFINITION OF TERMS

- ◆ Rated load is expressed when the outriggers are extended to maximum and to a distance below maximum with their spread angle set the same.
As a rule, set the outriggers extended to their extremes and with the spread angle of each 55° and 50° .
When any one of 4 outriggers has not been set to the maximum extension, the rated load other than maximum extension is to be applied which must be observed.
- ◆ Since prohibited range of crane operation is specified according to spread angle of outriggers, confirm it on the sticker.
If it is failed to observe, the crane may be overturned.

Outriggers extended to maximum

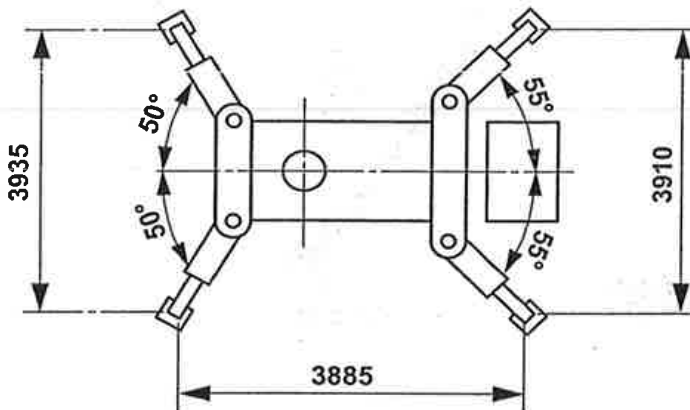

Outrigger setting with inner box extended to its maximum

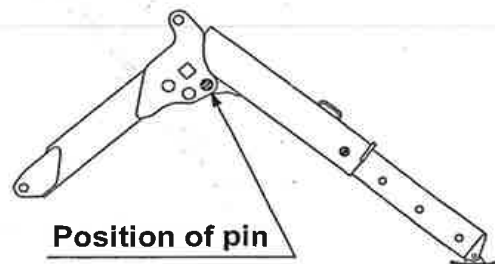

Example: Outrigger setting to a distance below maximum
(Figure shows they are set to minimum extension).

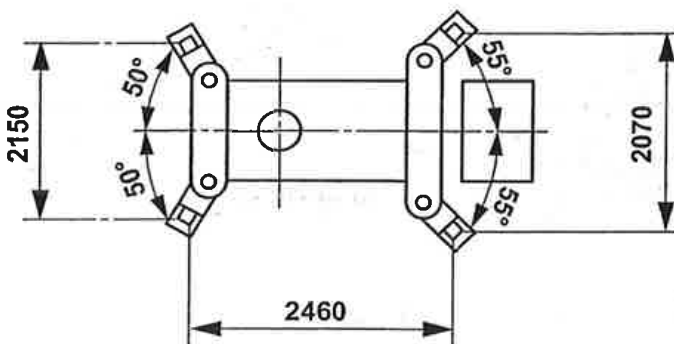

Outrigger setting with inner box pushed in to its minimum

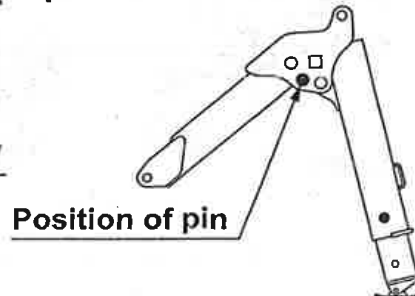

DEFINITION OF TERMS

2 *How boom-sections are extended*

5-section boom

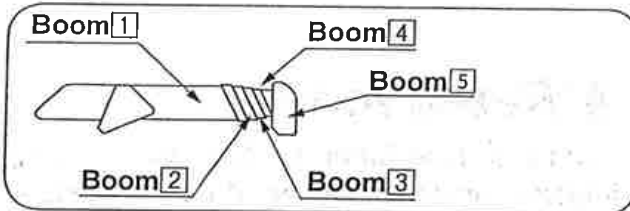

● **How boom-sections are extended**

Boom **1** :
All boom sections are retracted.

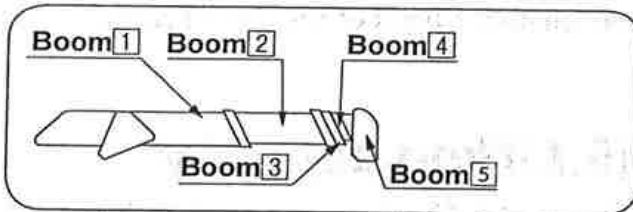

Boom **1+2** or **2** :
Boom section(2) only is extended.

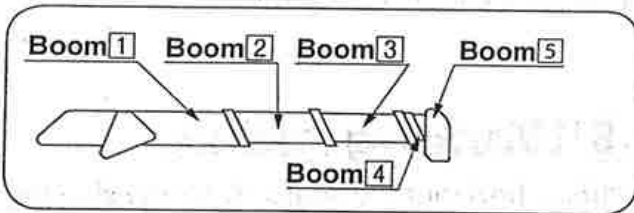

Boom **1+2+3** or **3** :
Boom sections(2) and (3) are extended.

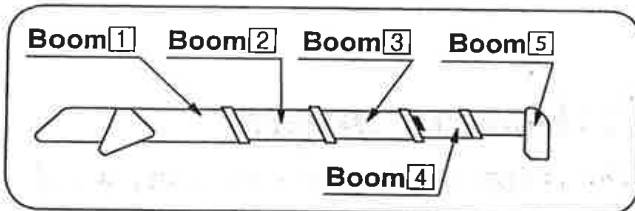

Boom **1+2+3+4** or **4** :
Boom section(4) is extended to the mark **▲** .

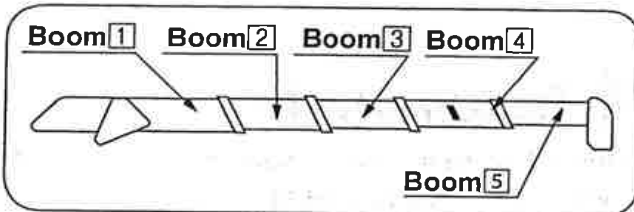

Boom **1+2+3+4+5** or **5** :
Boom-sections(2), (3), (4), and (5) are fully extended.

DEFINITION OF TERMS

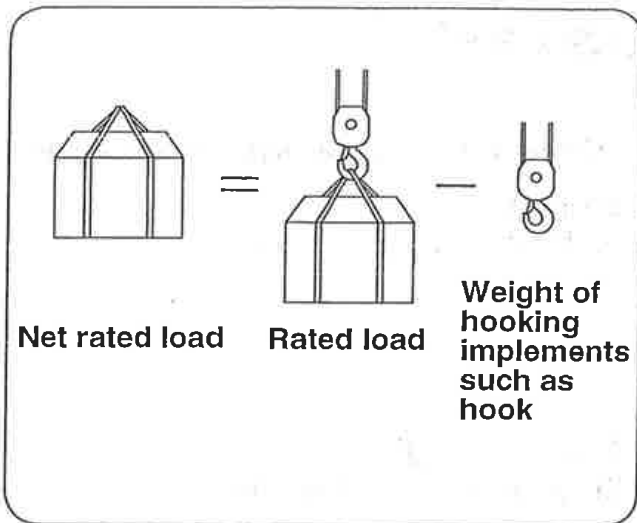

3 Net rated load

Net load which can be lifted by hook determined on the basis of stability of crane.

4 Rated load

Maximum load including hook and hooking implements which can be lifted according to the boom angle and/or the boom length determined on the basis of stability of crane.

5 Lifting capacity

This refers to maximum load of the rated load described section 4 above.

6 Working radius

This is horizontal distance from the slewing center to the hook center.

7 Boom length

This is distance from the boom foot pin to the sheave pin on the boom top.

8 Boom angle

This refers to an angle made by axis line of boom and the horizontal line.

9 Lift above ground

This refers to maximum vertical distance between bottom end of the hook to the ground surface with the hook wound up to touch the over-winding alarm detector.

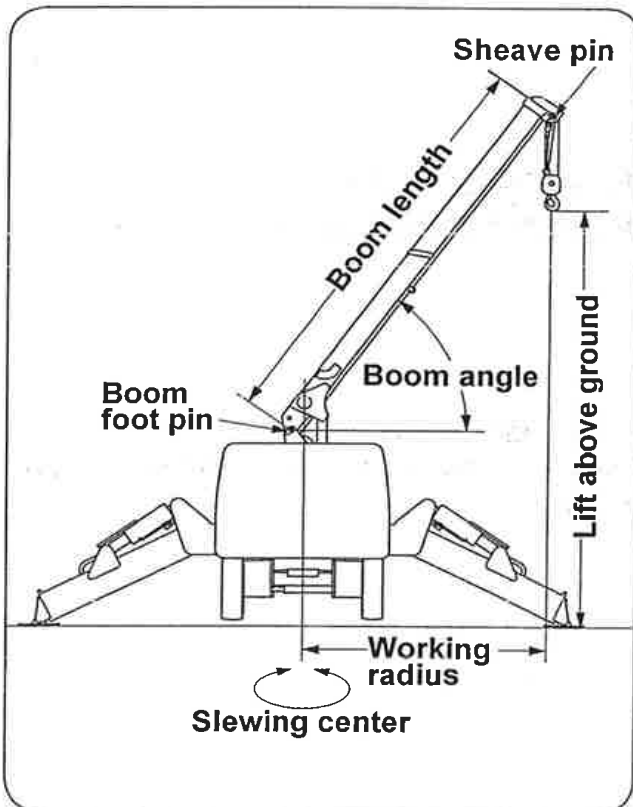

8. HOW TO REFER TO WORKING RANGE CHART AND RATED LOAD CHART

These charts are stuck in front of crane operation levers and how to refer to charts is illustrated as follows:

1 Working range chart

The chart shows the relation among boom length and working radius, boom angle, and lift above ground.

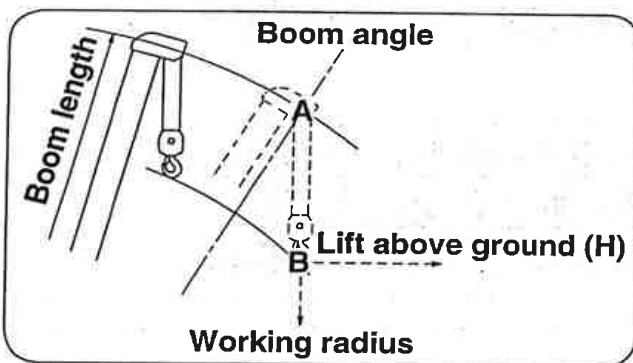
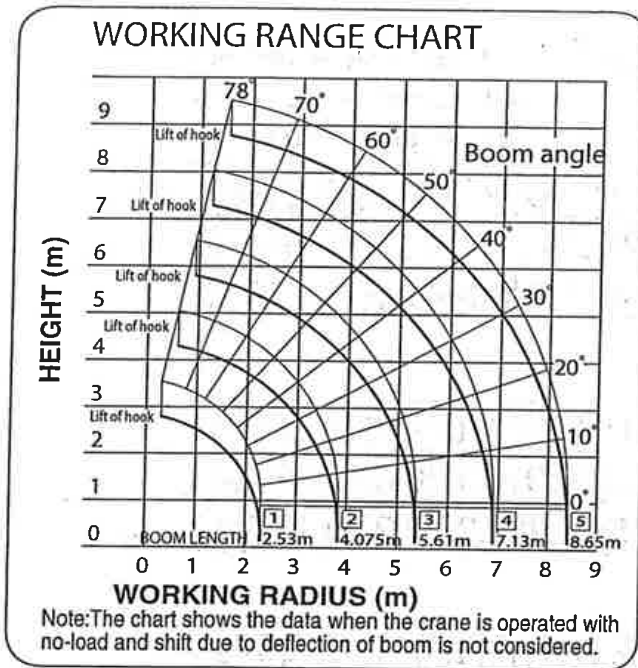

Although the point-A and the point-B follow the tracks along the same working radius, the point-A refers to the boom angle and the point-B the lift above ground.

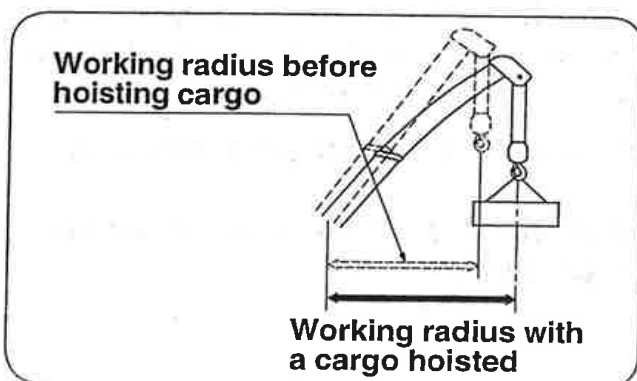

The working range chart does not incorporate any shift due to deflection of boom. Keep in mind that the actual working radius is somewhat extended due to boom deflection when a cargo is being hoisted.



HOW TO REFER TO WORKING RANGE CHART AND RATED LOAD CHART

2 Rated load chart

The chart shows maximum load which can be hoisted up for every combination of boom-sections to be extended for each working radius.

(The following chart shows an example for URW295WBE series)

NET RATED LOAD CHART

Net rated load is the lifting capacities excepted for the weight of the hook.

BOOM SECTION	1 • 1+2								
WORKING RADIUS (m)	1.0	1.4	1.5	1.8	2.0	2.5	3.0	3.5	3.835
NET RATED LOAD (t) <small>OUTRIGGER MAX EXT.</small>	2.9	2.9	2.65	2.25	2.05	1.65	1.3	1.0	0.9
LOAD (t) <small>OUTRIGGER NOT MAX EXT.</small>	2.0	2.0	2.0	1.45	1.1	0.65	0.49	0.35	0.25

BOOM SECTION	1+2+3								
WORKING RADIUS (m)	2.2	2.5	2.9	3.0	3.5	4.0	4.5	5.0	5.37
NET RATED LOAD (t) <small>OUTRIGGER MAX EXT.</small>	1.35	1.35	1.35	1.25	1.0	0.8	0.65	0.52	0.43
LOAD (t) <small>OUTRIGGER NOT MAX EXT.</small>	0.8	0.65	0.53	0.5	0.38	0.28	0.22	0.16	0.12

BOOM SECTION	1+2+3+4								
WORKING RADIUS (m)	3.4	3.8	4.0	4.5	5.0	5.5	6.0	6.5	6.89
NET RATED LOAD (t) <small>OUTRIGGER MAX EXT.</small>	0.85	0.85	0.75	0.6	0.5	0.42	0.36	0.32	0.27
LOAD (t) <small>OUTRIGGER NOT MAX EXT.</small>	0.42	0.34	0.3	0.25	0.19	0.14	0.1	0.08	0.06

BOOM SECTION	1+2+3+4+5									
WORKING RADIUS (m)	3.8	4.1	4.5	5.0	5.5	6.0	6.5	7.0	8.0	8.41
NET RATED LOAD (t) <small>OUTRIGGER MAX EXT.</small>	0.55	0.55	0.45	0.37	0.31	0.27	0.23	0.2	0.15	0.13
LOAD (t) <small>OUTRIGGER NOT MAX EXT.</small>	0.35	0.29	0.25	0.2	0.16	0.13	0.1	0.07	0.04	0.03

 **CAUTION**

★ The chart shows hoisting capacity when the crane is set up level with the outriggers extended and the data are based on actual working radius by incorporating shift due to deflection of the boom under loaded.

★ The rated loads specified above are based on strength of the crane and stability of the crane.

Be sure to check the chart for the rated load as it is to be changed according to how far the outriggers are extended.

9. DESCRIPTION OF EACH CONTROL DEVICE

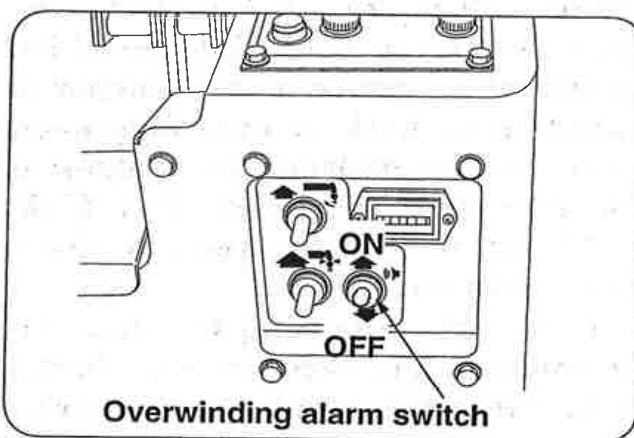
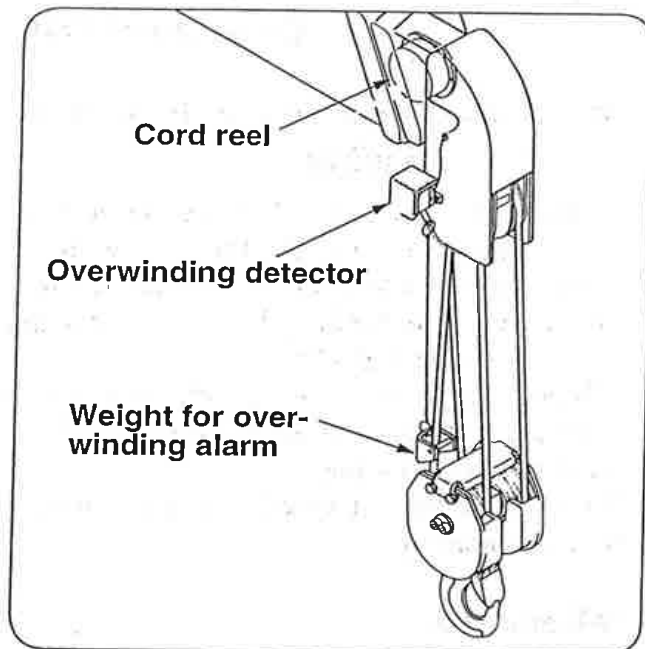

1 Overwinding alarm

◆ 1. Function of overwinding alarm

The device automatically makes an alarm sound to warn that the wire ropes are being over-wound when the hook comes close to the boom top.

◆ 2. Operating procedures

1 Turn ON the over-winding alarm switch before starting crane operation.

If the alarm sounds while the hook is being hoisted or the boom is being extended, stop the crane operation immediately and lower the hook or retract the boom.

2 Turn the alarm switch OFF after the crane work has been completed.

CAUTION

★ When the over-winding alarm switch is turned OFF, over-winding alarm will not function even if the hook is being overwound.

Be sure to turn the switch ON before starting crane work and check that the alarm sounds every time when the weight for over-winding alarm is lifted up to the detector.

★ Since the length of wire rope hanging the weight is specified by laws and regulations concerned, do not make it short at random.

★ The alarm sounds even if any of electric wires connected to the over-winding detector at the boom top is broken.

Ask an authorized UNIC service station for repair.

DESCRIPTION OF EACH CONTROL DEVICE

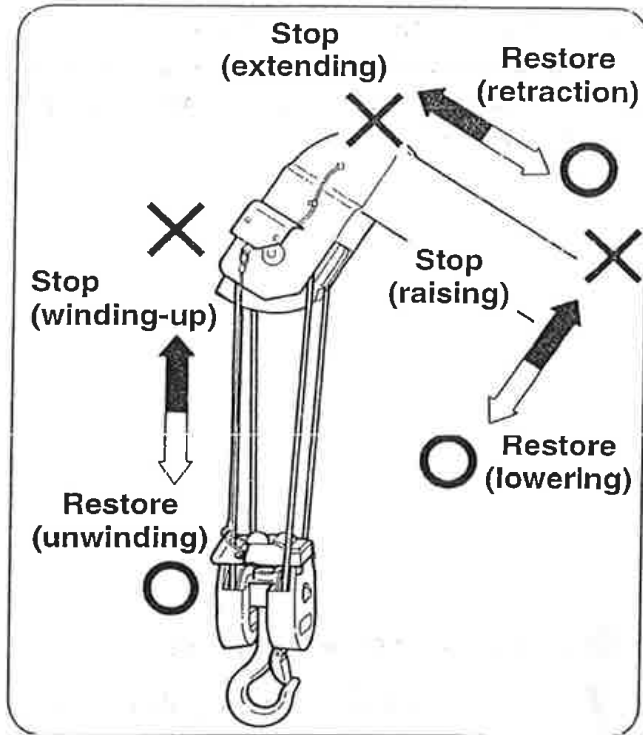

2 Automatic stop for overwinding

◆ 1. Function of automatic stop for over-winding

If the hook comes close to the boom top and it hits against the weight for over-winding alarm, buzzer sounds and functions of winding-up hook, extending boom, and raising boom stop automatically.

When the automatic stop is activated, lower the hook, retract or lower the boom until the buzzer stops sounding.

This allows the activated automatic stop to return to normal.

● **Remarks**

Since viscosity of hydraulic oil increases during cold winter or in low temperature environment, function of winding-up hook or extending boom may not stop perfectly but it allows to make a slight movement even if the hook hits against the weight which is not a disorder.

Carry out warming-up and the automatic stop recovers functioning when temperature of hydraulic oil rises to a certain level.

◆ 2. How to reset when automatic stop for over-winding is found out of order

If crane can not be operated due to failure in the automatic stop, reset the automatic stop and store the crane.

● **Step 1**

Turn the reset switch for the automatic stop to "Reset" to reset the automatic stop.

Then wind up the hook, extend or raise the boom by controlling operation lever.

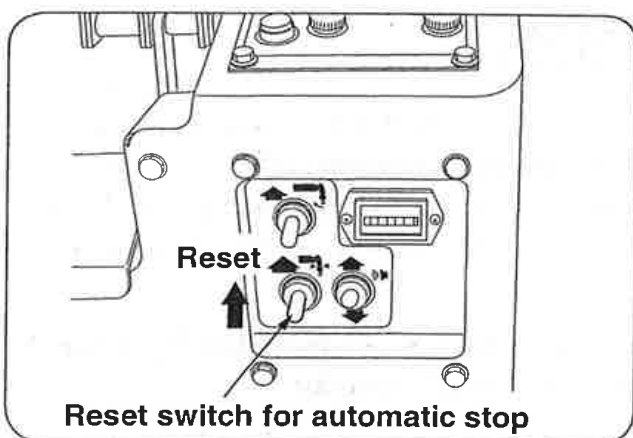

DESCRIPTION OF EACH CONTROL DEVICE

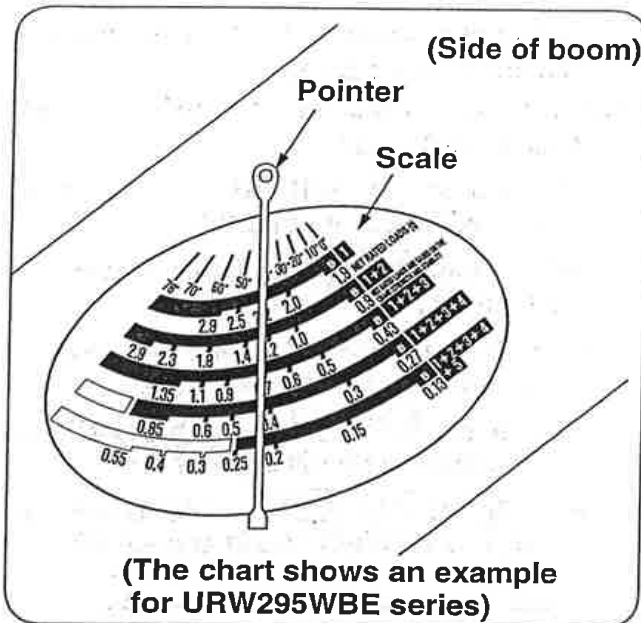

3 Load indicator (With angle meter)

The indicator reads the rated load corresponding to extended length of boom and its angle to show the maximum weight of cargo which can be hoisted at this point.

◆ 1. Net rated load

The value to which the needle points on the scale of meter is the rated load in each combination of boom-sections being extended.

◆ 2. Boom angle

Deflection of the needle on the angle scale reads the boom angle.

⚠ CAUTION

- ★ The load indicator reads the rated load when the outriggers are fully extended.
- ★ The load indicator can not be used when the outriggers are extended to a halfway or to minimum.
- ★ Use a proper scale band according to boom-sections being extended.



DESCRIPTION OF EACH CONTROL DEVICE

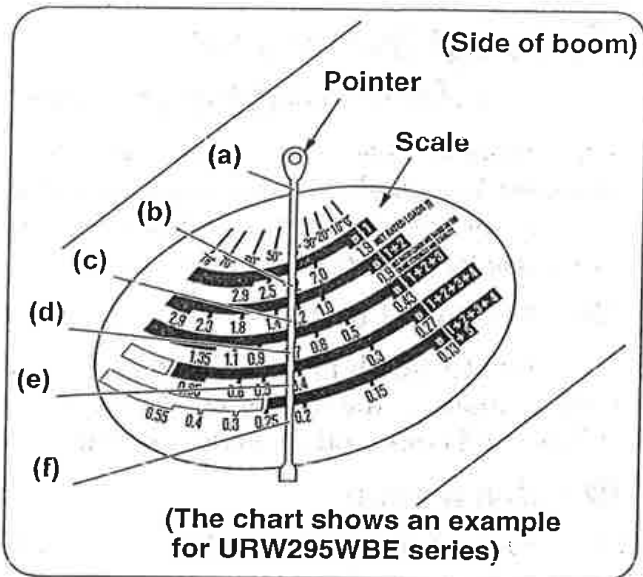

[Example]

How to read when the needle deflects as shown in the figure.

- (1) Boom angle reads 41° at the point (a) on the boom angle scale.
- (2) Maximum load which can be hoisted (rated load) reads:
 - For boom [1] (With all boom sections retracted) : 2.2t at point (b).
 - For boom [1+2] (With boom section [2] extended) : 1.2t at point (c).
 - For boom [1+2+3] (With boom-section [3] extended) : 0.7t at point (d).
 - For boom [1+2+3+4] (With boom-section [4] extended) : 0.42t at point (e).
 - For boom [1+2+3+4+5] (With boom-section [5] extended) : 0.22t at point (f).

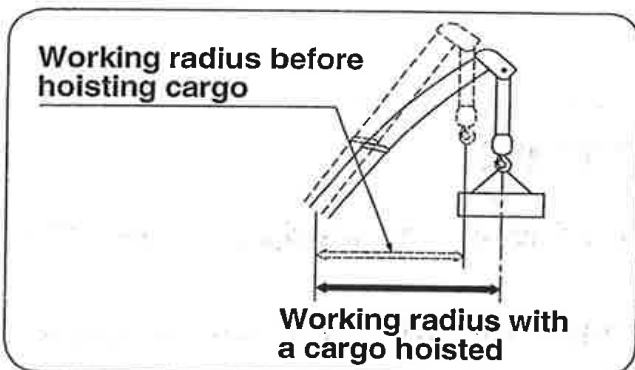

CAUTION

★ When a boom is extended to halfway, use the rated load with the boom concerned fully extended in order to secure safety.

- When boom-section [2] is extended from boom-section [1], take the net rated load for boom [1+2] (1.2t in the example shown above).
- When boom-section [3] is extended from boom-section [2], take the net rated load for boom [1+2+3] (0.7t in the example shown above).

★ Since the working radius increases due to deflection of the boom when a cargo starts to be lifted up, set the boom angle so that the hook comes to somewhat inner side.



DESCRIPTION OF EACH CONTROL DEVICE

◆ How to refer to hoisting capacity when outriggers are extended to minimum or to halfway.

As a general rule, the outriggers are to be extended to their extremes.

If it is forced to operate the crane with the outriggers extended to minimum or to halfway, operate the crane in accordance with instructions shown below.

1. Find the working radius.
2. The rated load is to be obtained from the data shown in the "outriggers extended to minimum on the chart of rated load" according to how boom-sections are extended.
 - When operated with the working radius of 3.5m, with the extended boom configuration of **1+2**, and with outriggers extended to halfway or to minimum, take 0.35t.
 - When operated with the working radius of 3m, with the extended boom configuration of **1+2+3**, and with outriggers extended to halfway or to minimum, take 0.5t.

NET RATED LOAD CHART

Net rated load is the lifting capacities excepted for the mass of the hook.

BOOM SECTION		1 • 1+2								
WORKING RADIUS(m)		1.0	1.4	1.5	1.8	2.0	2.5	3.0	3.5	3.835
NET RATED LOAD(t)	OUTRIGGER MAX EXT.	2.9	2.9	2.65	2.25	2.05	1.65	1.3	1.0	0.9
	OUTRIGGER NOT MAX EXT.	2.0	2.0	2.0	1.45	1.1	0.65	0.49	0.35	0.25

BOOM SECTION		1+2+3								
WORKING RADIUS(m)		2.2	2.5	2.9	3.0	3.5	4.0	4.5	5.0	5.37
NET RATED LOAD(t)	OUTRIGGER MAX EXT.	1.35	1.35	1.35	1.25	1.0	0.8	0.65	0.52	0.43
	OUTRIGGER NOT MAX EXT.	0.8	0.65	0.53	0.5	0.38	0.28	0.22	0.16	0.12

(The chart shows an example for URW295WBE series)

 **CAUTION**

★ When the outriggers are extended to minimum or to halfway, operate the crane according to capacity obtained from the "outriggers extended to minimum or to halfway accordingly on the chart of rated load".

★ The load indicator can not be used when the outriggers are extended to minimum or to halfway.

DESCRIPTION OF EACH CONTROL DEVICE

4 Load meter

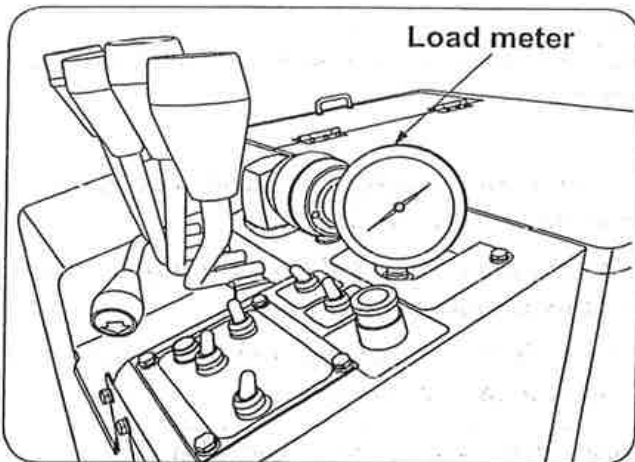

The meter shows weight of a cargo being hoisted. Read the scale band corresponding to the wire-rope hooking system (number of wire ropes being hooked).

● **Remarks**

The load meter is fixed on the panel.

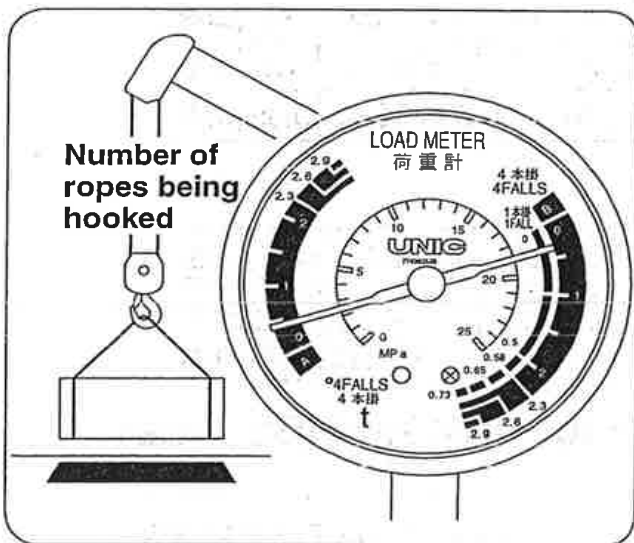

◆ **Dial of load meter has:**

- Scale bands corresponding to A and B for 4-rope hooking system,
- Scale band for single-rope hooking system.



CAUTION

★ "Load meter" indicates the weight of a hoisted cargo only while the hook is being lifted up and it will not show the weight while other operations, such as when stopping winding up and lowering a cargo, are being carried out.



DESCRIPTION OF EACH CONTROL DEVICE

◆ Follow the steps illustrated below when measuring weight of a hoisted cargo with the load meter.

Compare the reading on the load meter with the reading on the load indicator.

① Allow the motor to run at a low speed.

② Adjust the lifting-up speed of hook so that the needle may point at 0 (zero) on the load meter scale by lifting up hook with no-load.

Measure the weight of a cargo at the lifting-up speed adjusted.

- Shift the lever for winding-up hook to the position just before the motor starts increasing its speed by auto-acceleration.

This will not be measured by a slight control of the lever for winding-up hook.

- For radio-remote control types, when it is measured by winding-up hook control using the manual control lever after the speed mode has been switched to a very slow speed mode by the radio-remote controller, the measurement can easily be done as the motor speed will not be increased.

- Weight measurement through radio-remote controller can only be done in the fastest speed mode. It cannot be measured in the mode of medium or slow speed.

③ Taking an example of the case where a cargo is hoisted up by using 4-rope hooking system and with the extended boom configuration of $1+2+3$.

The load indicator shows at point (a) that the crane can lift up the load up to "0.7t" (Fig. 1).

④ Read the load meter for the point (b) on the scale band of "B" while a cargo hooked is being lifted up to approximately 30cm above the ground (Fig. 2).

The meter shows "0.5t" for the actual weight of the cargo.

This means that the crane can be operated with a margin of 0.2t in the example.

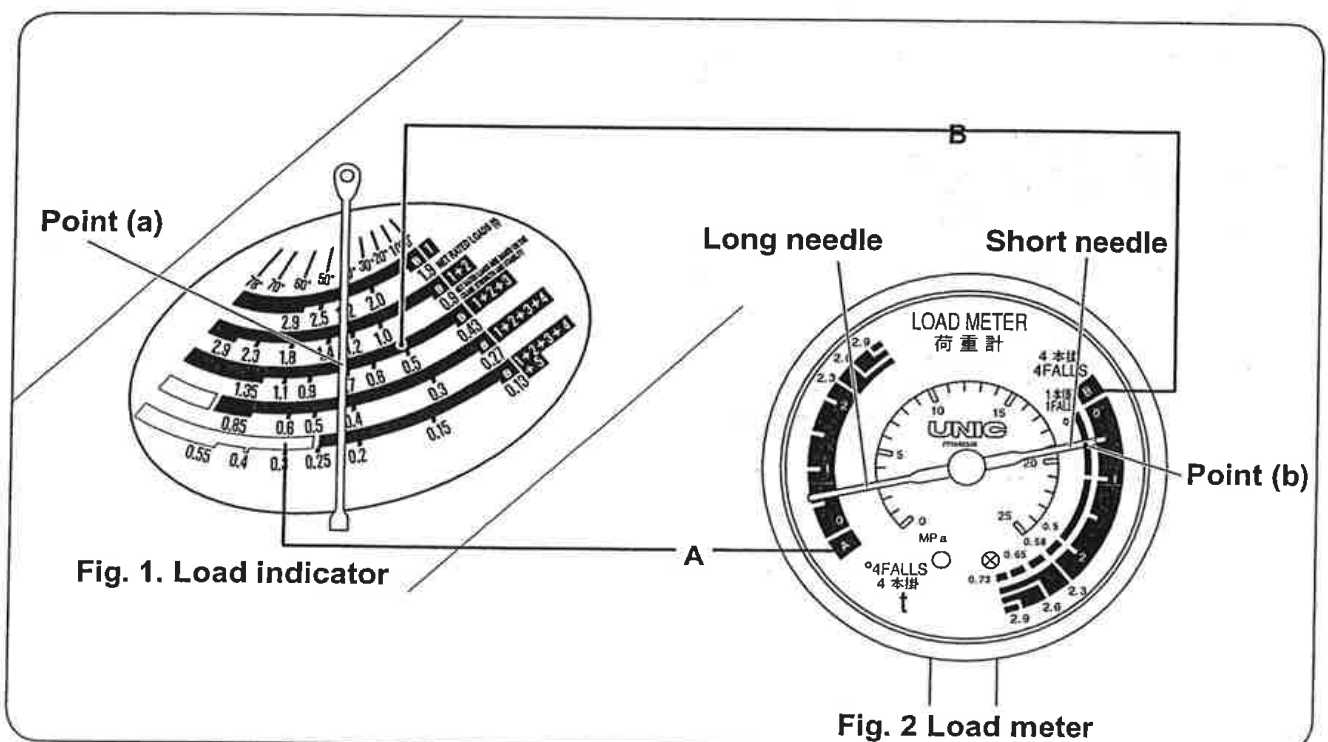

DESCRIPTION OF EACH CONTROL DEVICE

◆ Check for safety operation

① If a crane is loaded so much that readings on the load meter exceeds the rated load, the crane can be damaged or overturned.

In such case, move the wheel crane closer to the cargo to be hoisted to decrease the working radius, then operate the crane again within the rated load.

② When the load meter reads less than the specified rated load in the chart, the cargo can be lifted up safely.

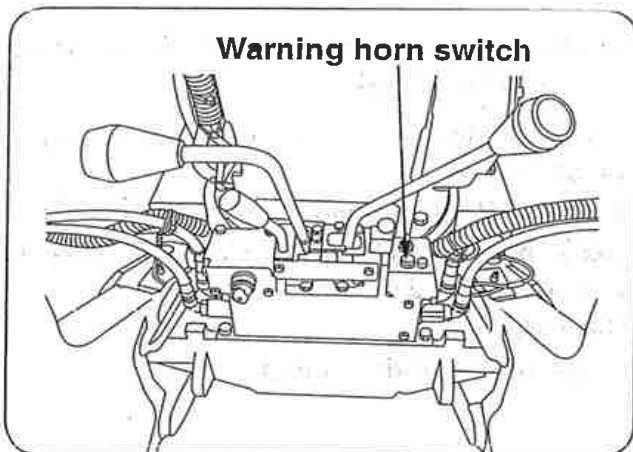

5 **Warning horn**

Before lifting up the cargo, depress the warning horn switch on the travel panel to give warning sound to those who have entered within slewing range during crane operation, or to workers in charge of slinging work near the cargo or in a course where the cargo may pass along.

Depress the switch button to give warning sound.

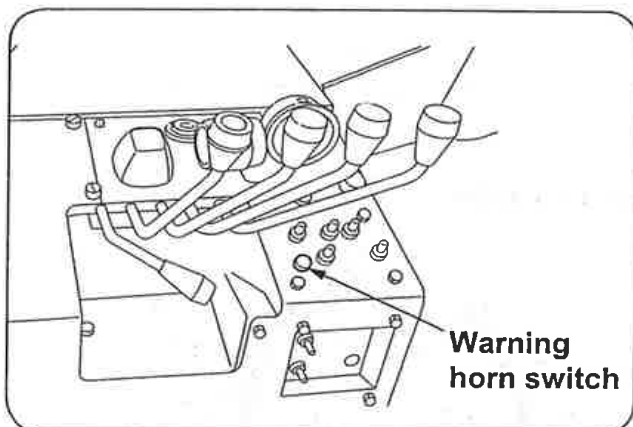

DESCRIPTION OF EACH CONTROL DEVICE

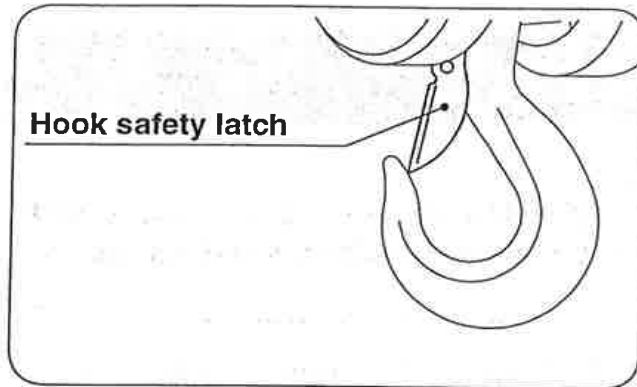

6 *Hook safety latch*

The mechanism is to prevent slinging wire rope from being disengaged out of the hook.



7 *Automatic stop for leaving minimum wire rope (with wire rope retaining roller)*

This is a device to restrict slackening of wire rope on the drum.

The device prevents the rope on the drum from slackening when winding up and down the hook or making it an abrupt stop and when the hook is lowered to the ground.

In addition, it allows to stop unwinding automatically when remaining wire ropes on the drum come close to 3 turns so that the rope can not be unwound further.

DESCRIPTION OF EACH CONTROL DEVICE

8 Specifications on turnover prevention device (URW095WBE)

! WARNING

★ Observe the caution to secure safety.
Failure to observe the cautions may invite trouble or serious accident.
Be sure to carry out the inspection in particular before starting operation.

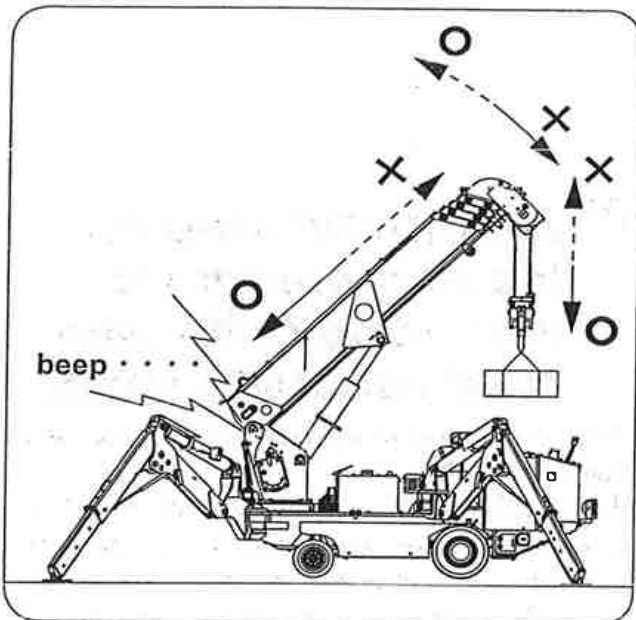

1 Carry out careful inspection before operation, and daily and periodical inspection to confirm that the turnover prevention device functions properly.

2 The turnover prevention device is a safety device that allows to slow down operating speed gradually while making an intermittent warning sound when the ground reaction against the outrigger located on opposite side of the boom decreases to the specified level due to increase of crane moment.

If the reaction force of the outrigger decreases further, the warning changes to continuous sound and the crane makes an automatic stop. Crane functions to be stopped are : winding up hook, extending boom, and lowering boom.

Check the turnover prevention device for proper operation before starting the crane operation.

3 If the crane is operated via radio-controller, operate it within the range where the alarm sound can be heard.

4 Over-loaded operation is strictly prohibited.

The turnover prevention device is not a device for preventing overload.

It is the principle that you should persistently observe the operation within rated load.

Do not put too much confidence on the device.

Leaning of the crane due to swing of a lifted cargo or parking on unlevelled ground may allow the crane to be overturned.



DESCRIPTION OF EACH CONTROL DEVICE

5 If an alarm sounds intermittently due to decrease of ground reaction against outriggers, operating the crane to safer side.

If the reaction force of the outrigger decreases further, the crane makes an automatic stop. In this case, faster operating speed can make the crane to be overturned to which must pay attention.

6 Observe that the crane shall not be operated within the prohibited range in extending outriggers.

The turnover prevention device will not function safely when the crane is operated within the prohibited range.

7 Keep the "ON-OFF" switch for alarm buzzer turning ON unless there is any special reason.

8 As a rule, set up the crane on a flat and solid ground to operate it with the outriggers extended to their extremes, with the truck kept level, and with the rubber tire lifted up by approx. 50mm above the ground.

DESCRIPTION OF EACH CONTROL DEVICE

◆ 1. Structure of turnover prevention device

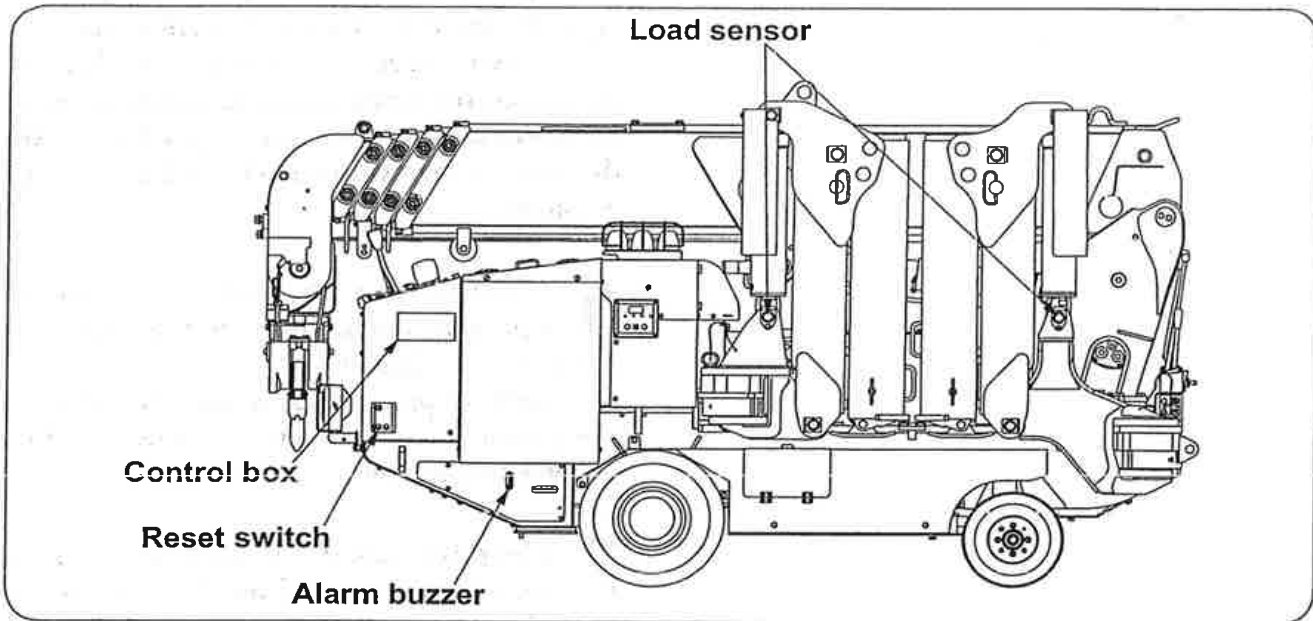

◆ 2. Inspection before starting crane operation

WARNING

★ Be sure to carry out inspection of turnover prevention device before starting the crane operation to check that the device functions normally.

If found something wrong with the device, ask a UNIC authorized service shop for repair as soon as possible.

★ Turn "ON" the turnover prevention alarm buzzer switch while carrying out preparation of the crane operation to check that continuous alarm sound is heard until the outriggers are set up on the ground. If the alarm fails to sound, ask a UNIC authorized service shop for repair immediately as something is wrong with the turnover prevention device.

★ The crane might be overturned even if the system has been actuated when a lifted cargo is swinging and/or operation speed is too fast because the load is increased by inertia.

Do not rely too much on the system but try always carrying out safe operation of the crane carefully by observing that the load is kept within the rated load.

DESCRIPTION OF EACH CONTROL DEVICE

Check the following before starting crane operation,

If found something wrong with the turnover prevention device, contact with a UNIC authorized service shop as soon as possible because it will not function as a safety device.

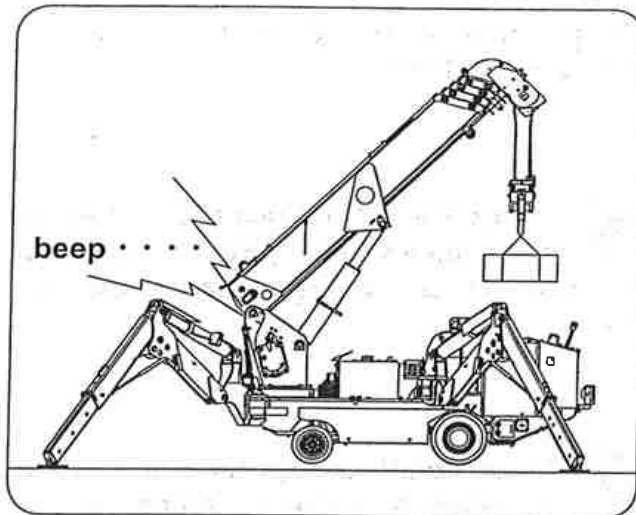

1 Check that the continuous alarm sound (bee ee) of the turnover prevention device is issued before setting up outriggers.
(Keep always the "ON-OFF" switch for alarm buzzer turning ON.)

2 By following procedures for setting up the outriggers on the ground, rotate the outriggers to secure them with the lock pins at this time, allow the outriggers to be fully retracted without setting them up on the ground.

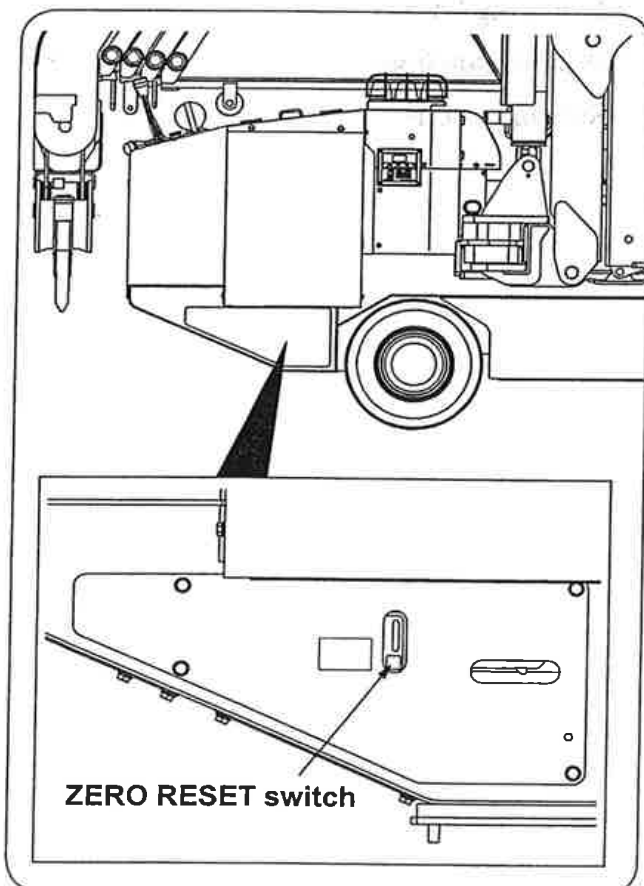

3 Through the hole on the side of operation panel, depress the "ZERO RESET" switch in the control box of turnover prevention device mounted inside for 1 second.

★ When the zero-point adjustment has successfully been completed, all the lamps for self-diagnosis light for 2 seconds and the overturn alarm buzzer will stop sounding for 2 seconds.

After that, "RUN" lamp (green) lights and lamps of "ch. A" through "ch. D" blink. In addition, the overturn alarm buzzer makes a continuous sound.

4 Confirm that the alarm buzzer stops sounding when the outriggers have been set up on a solid and level ground.

(Set them up so that the crane body can be positioned at 50mm off the ground.) Check at this time that lamps of "RUN" and "ch. A" through "ch. D" among the self-diagnosis lamps in the control box of turnover prevention device lights or blinks.

DESCRIPTION OF EACH CONTROL DEVICE

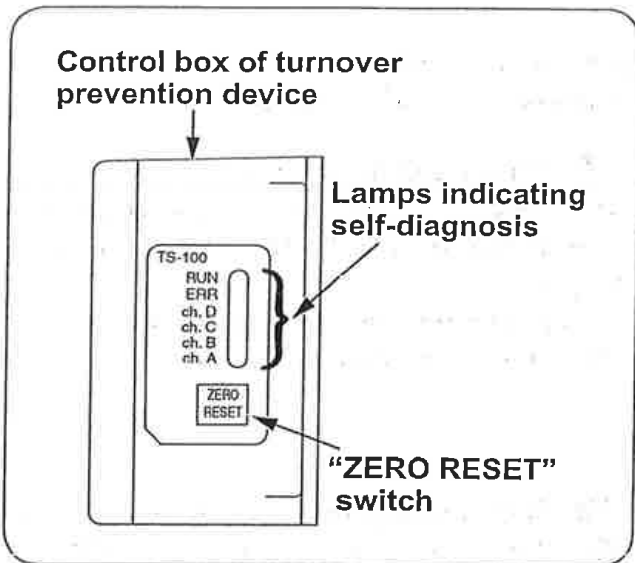

5 After the outriggers have been set up properly and the buzzer is making no alarm sound, check that the alarm buzzer starts to make an intermittent sound (beep, beep) when the two adjacent outriggers are retracted gradually.

6 Check also that the alarm buzzer makes a continuous sound (bee . . . ee) when the two adjacent outriggers are retracted further.

7 In the condition that the alarm buzzer is making a continuous sound (bee . . . : ee), following crane operation will become impossible

- Extension of boom
- Lowering boom
- Winding-up hook
- Slewing boom

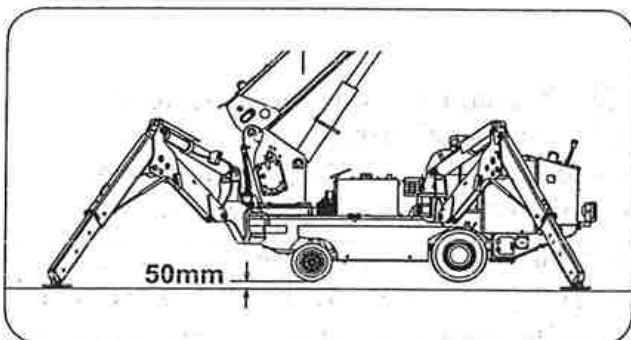



DESCRIPTION OF EACH CONTROL DEVICE

 **CAUTION**

★ Do not carry out “zero point adjustment” for turnover prevention device after the outriggers have been set up.

Depression of “ZERO RESET” switch in this condition, the “zero point adjustment” does not complete successfully which in turn the turnover prevention device will be in failure so that crane operation of winding-up hook, extension of boom, lowering boom, and slewing boom cannot be possible.

In this case, store the crane by following the step 1 illustrated on page 9-19, “How to release when turnover prevention device” is found to be out of order, then store the outriggers to depress the “ZERO RESET” switch again.

★ Although in case where the “zero point adjustment” has been completed, the “RUN” lamp fails to be lit, or if lamps of “ch. A” through “ch. D” are blinking even after the outriggers have been set up right, ask a UNIC authorized service shop immediately for inspection and repair as the reaction force detector may be out of order.

★ After the “zero point adjustment” has been completed right, if the “ERR” lamp blinks for only 5 seconds and the alarm buzzer makes an intermittent sound (Beep, Beep) at the same time when the “RUN” lamp lights, it indicates that the reaction force detector should be replaced. Although the reaction force detector can be used for some time, ask a UNIC authorized service shop as early as possible for repair.

★ In case where the “ERR” lamp in the control box of turnover prevention device is blinking, the alarm buzzer makes a brief intermittent sound (Pi, Pi, Pi . . .).

Since this indicates that the turnover prevention device is in trouble, ask a UNIC authorized service shop immediately for inspection and repair.

DESCRIPTION OF EACH CONTROL DEVICE

◆3. Function of turnover prevention device

Carry out normal crane operation after completion of inspection before starting crane operation. The turnover prevention device is a safety device that prevents the crane from being overturned by stopping crane functions automatically while issuing alarm sound when the average setting-up reaction force of the ground against two (2) adjacent outriggers on the opposite side of the boom reaches the specified set value.

The setting-up reaction force of the ground against each outrigger is always detected by load cell.

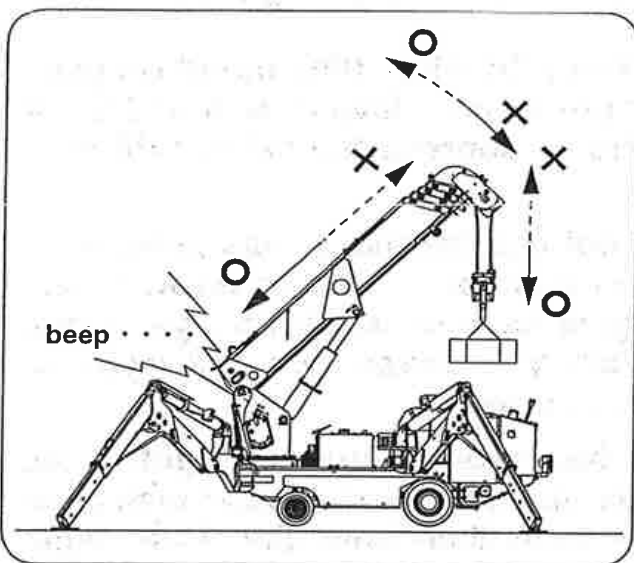

1 Advance alarm for overturn

When the average of setting-up reaction force of the ground against two (2) adjacent outriggers on the opposite side of the boom decreases, the alarm buzzer makes an intermittent alarm sound (beep, beep) of advance alarm to give a warning.

If the alarm is heard, slow down operation speed of the crane to operate it for safer side immediately.

2 Threshold alarm for overturn

When the average of setting-up reaction force of the ground against two (2) adjacent outriggers on the opposite side of the boom decreases further and it becomes dangerous conditions, the alarm buzzer makes a continuous threshold alarm sound (bee ee) to give a warning and following functions of the crane are to be stopped automatically:

- Hoisting hook
- Extending boom
- Lowering boom
- Slewing boom

★ The crane may be overturned due to swing of a lifted cargo such as by an abrupt stop when the crane is operated in high speed to which special attention must be paid.

★ If sound of alarm buzzer should be avoided such as in working at night or working in residential areas, turn OFF the alarm buzzer switch to stop the buzzer.

Turn it ON when in normal crane operation.

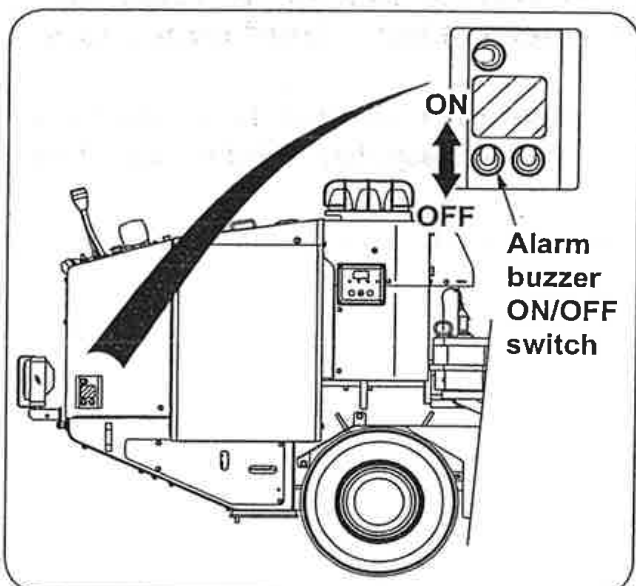

DESCRIPTION OF EACH CONTROL DEVICE

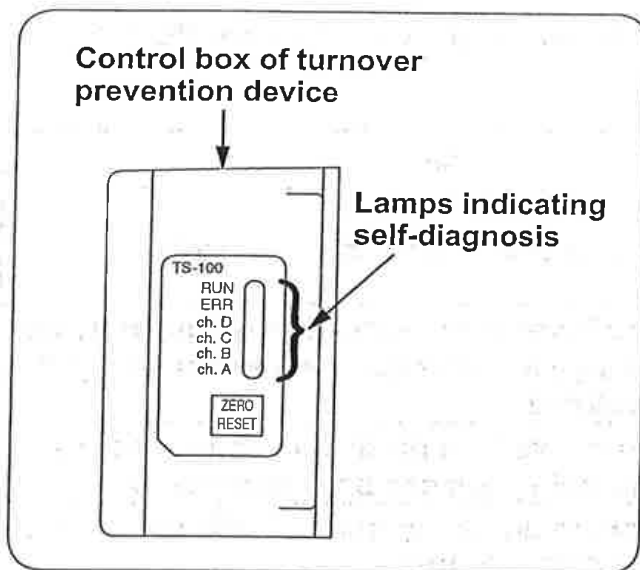

◆ 4. Self-diagnosis functions

"Lamps indicating self-diagnosis" are mounted in the control box of turnover prevention device to show such as operation, detailed faults of the device.

"RUN" lamp (green)

It lights when the turnover prevention device is functioning right.

"ERR" lamp (red)

It lights when the reaction force detector is in trouble.

"ch. D" lamp (orange)

It lights or blinks according to outriggers on the rear-right side of the crane body.

"ch. C" lamp (orange)

It lights or blinks according to outriggers on the front-right side of the crane body.

"ch. B" lamp (orange)

It lights or blinks according to outriggers on the front-left side of the crane body.

"ch. A" lamp (orange)

It lights or blinks according to outriggers on the rear-left side of the crane body.

★ The lamps of "ch. A" through "ch. D" indicate condition of each outrigger separately how it touches the ground and the alarm of the turnover prevention device is to be determined by combination of two (2) adjacent outriggers with smaller reaction force against combination of outriggers than other combination.

★ All the self-diagnosis lamps light up for approximately 2 seconds after the crane traveling lever interlock has been switched to the crane. Self-diagnosis for the turnover prevention device is being carried out while the lamps for self-diagnosis are being lit.

★ In case of URW295WBE type, remove the set pins out of outriggers to rotate them to their specified positions, the self-diagnosis lamps light up for approximately 2 seconds when 4 pieces of set pins have fully been inserted.



DESCRIPTION OF EACH CONTROL DEVICE

● **Indication of lamps for self-diagnosis when turnover prevention device functions normally**

Lamps	Indication	State
RUN	Lighting	Turnover prevention device is functioning right.
ERR	Lighting off	
ch.D	Quick blinking	It is in condition of overturn threshold as ground reaction force against outriggers has been decreased, or outriggers have been stored.
ch.C	2 blinks at a time	It is in condition of overturn prediction as ground reaction force against outriggers has been decreased.
ch.B		
ch.A	Lighting or slow blinking	Crane can be operated safely due to sufficient ground reaction force against outriggers.

● **Indication of lamps for self-diagnosis when turnover prevention device is in trouble**

◆ **When reaction force detector is in trouble**

Lamps	Indication	State
RUN	Lighting off	Reaction force detector is in trouble.
ERR	Quick blinking	
ch.D	Quick blinking	Reaction force detector is in trouble.
ch.C	Lighting	Reaction force detector is working right.
ch.B		
ch.A		

◆ **When control box of turnover prevention device is in trouble**

All the lamps for self-diagnosis do not light.

 **CAUTION**

In case where the crane cannot be operated because a trouble has been occurred to the turnover prevention device while the crane is being operated, turn OFF the motor key once then start the motor again.

If the trouble fails to be solved, store the crane by following the steps illustrated on page 9-19, "How to release when turnover prevention device" is found to be out of order, then ask a UNIC authorized service shop for repair.

DESCRIPTION OF EACH CONTROL DEVICE

◆ **5. How to release when turnover prevention device is found to be out of order**

If the crane cannot be operated due to trouble in the turnover prevention device, store the crane in accordance with steps as follows:

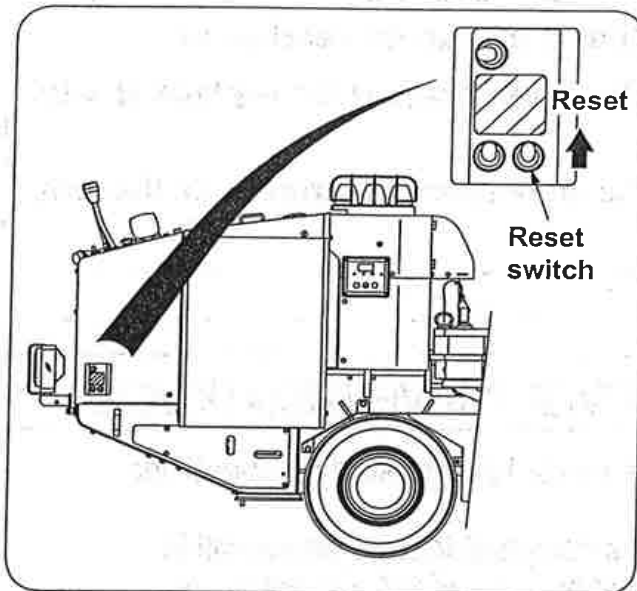

● **Step 1**

The release switch for turnover prevention device is located inside of the cover near the left front of the crane.

Operate the crane while the release switch is being pushed up.

If the crane is operated with the release switch pushed up, the device loses the functions as the safety device.

Operate the crane by paying special attention that the crane will not be overturned.

If any of outriggers is raised before the boom and the hook have been stored, the turnover prevention device is to be actuated so that the crane turns to be inoperable.

Store the crane while the release switch is being pushed up.

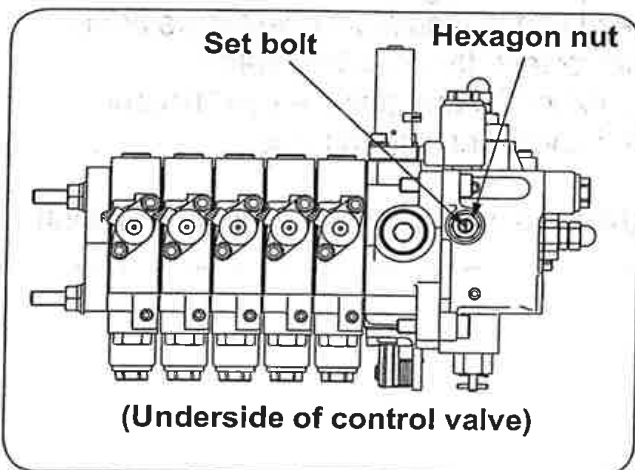

● **Step 2**

If the crane cannot be operated (it will not function) by taking measures in "step 1" above, operate the crane by following procedures below.

Unfasten the hexagon nut on the side of unload valve attached to underside of the control valves to tighten up the set bolt being locked until it comes to a stop.

Since this allows the crane to be operated, store the crane by controlling levers.

CAUTION

★ Since this is a temporary measures in an emergency, be sure to repair it at a UNIC service shop after the crane has been stored.

DESCRIPTION OF EACH CONTROL DEVICE

◆ 6. Caution plates in detail

 **CAUTION**

- ★ Always keep the stickers clean so that they can be read easily.
- ★ If any of the stickers has come off, stick it again or replace it with new sticker.
- ★ When ordering stickers, specify the part number shown at the bottom-right of the sticker concerned.

 **CAUTIONS TURN OVER PREVENTION DEVICE**

- Be sure to perform inspection (pre-start inspection) before starting operations to make sure that this device works.
- Overload is strictly prohibited. This device is designed for operations within the rated load in principle and not for prevention of overload. Do not have too much confidence in this device. If the crane inclines due to swing of load or grounding on rough terrain, it could turnover.
- As ground reaction force is lowering, a warning indicating that turnover is close is given. Slow down the operating speed and immediately operate the crane to a safe side. If ground reaction force further lowers, the following crane movements stop automatically. In this case, extreme care must be used because the crane may turnover due to swing of load if the crane speed is fast.
 - Hoisting of hook
 - Extension of boom
 - Lowering of boom
 - Swing to right and left



10. DESCRIPTION OF EQUIPMENT FOR BATTERY DRIVE

WARNING

- ★ Use the electric power unit properly. Improper use may cause electrical shock, high temperatures, fire or injury.
- ★ Do not connect or disconnect the plug while the power unit is running.
- ★ Do not charge the battery while the power unit is running.
- ★ Do not disassemble the power unit.
- ★ Do not perform high pressure cleaning.

CAUTION

- ★ The unit will become hot when the electric power unit is used continuously. Be careful not to burn yourself.
- ★ There is a charge that the battery level may not be indicated immediately after the power for the power unit is turned on.
- ★ To prevent the crane from being tampered with, remove the power supply key whenever the power unit is not in use.
- ★ After the power is turned on the crane runs a system diagnostic for around three seconds. Do not operate the crane during this time. If the crane is operated during the system diagnostic, "E.94" lights and crane operation becomes inexecutable.
In this instance, turn on the power once more. System diagnostics will be performed again.

DESCRIPTION OF EQUIPMENT FOR BATTERY DRIVE

1 Operation panel

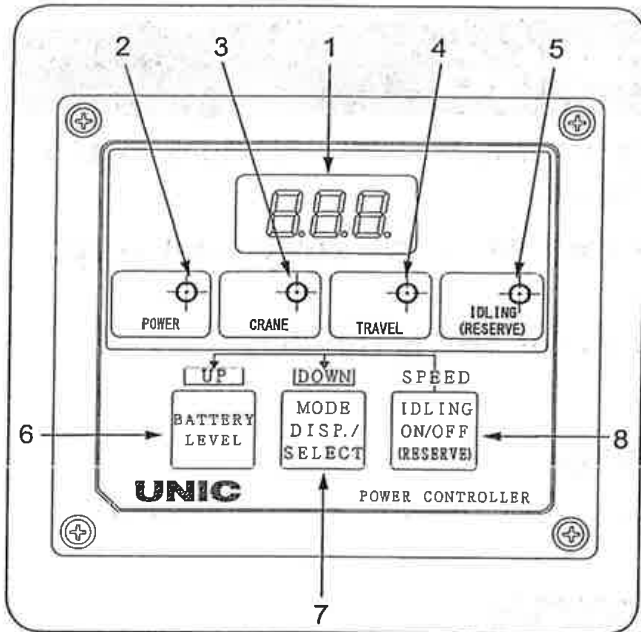

1 Mode indicator

Displays the operation mode according to the operation and battery level.

2 Power LED lamp

Lights when the power unit is activated.
Blinks when the battery level is at 10% or less.

3 Crane mode LED lamp

Lights when the crane mode is activated.

4 Travel mode LED lamp

Lights when the travel mode is activated.

5 Idling mode LED lamp/reserve mode LED lamp

Lights when the idling mode is activated.
Blinks when the reserve mode is activated.

6 Battery level check button

A button to check the battery level.
Press once and the battery level (0-100%) is displayed.

Three seconds after pressing the button, the screen returns to the normal.

7 Operation mode display /select button

When pressed once, the current operating mode is displayed.

If the button is pressed again when the mode is being displayed, the operation mode switches.

8 Idling ON/OFF button

If the button is pressed, idling starts.

If pressed during idling, idling stops and normal screen returns.

DESCRIPTION OF EQUIPMENT FOR BATTERY DRIVE

2 Charging port

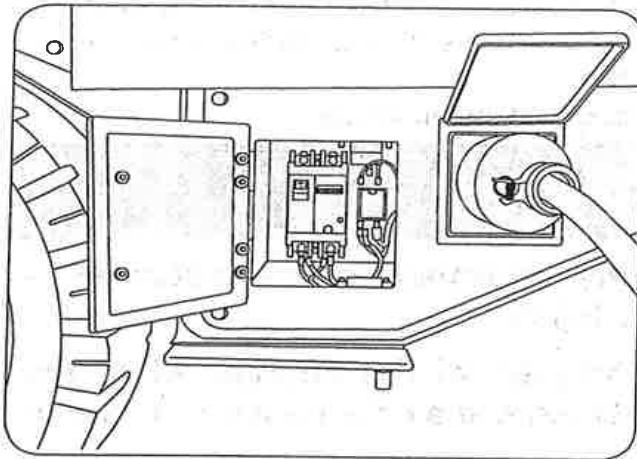

When charging connect the plug from the wall outlet.
Keep the cover closed except when charging.

CAUTION

★ When charging always keep the ventilation cover at the top of the battery open.

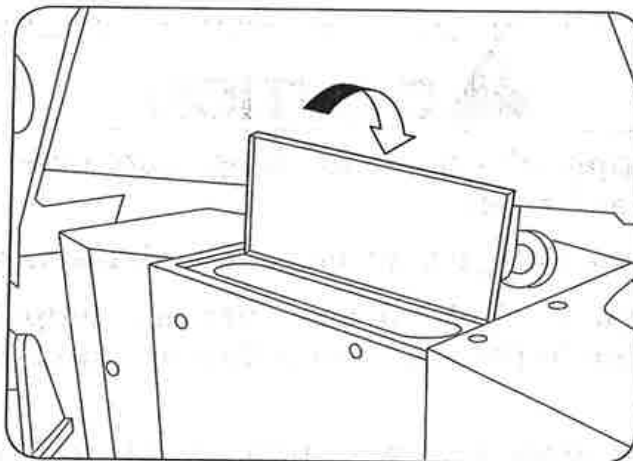

DESCRIPTION OF EQUIPMENT FOR BATTERY DRIVE

3 How to charge the battery

Use single-phase 200 V power supply to charge the battery. Be sure to install one dedicated electromagnetic switch per unit in the power supply system based on the instructions of a chief electrical engineer or have an expert installer install it.

Use an electromagnetic switch outfitted with a short circuit circuit breaker.

! WARNING

- ★ Use the charger and battery correctly. Improper use can cause electrical shock, high temperatures, fire or injury.
- ★ Do not connect and disconnect the plug of the charger while the power switch of the charger is ON. Sparks may fly causing a fire or explosion.
- ★ Do not use the charger for any purpose other than the charging of specified batteries. Using the charger outside its intended purpose might damage the charger.
- ★ Do not disassemble the charger and battery. Do not insert or connect metal with the body of the charger, and with the connection parts of the power cord and output cord.

! CAUTION

- ★ Use a power supply of a specified range (commercial) for the power supply input for the charger.
- ★ When inserting the plug, firmly insert it in all the way.
- ★ Do not place objects on the power cord and output cord. Check for cracks and corrosion in the core wires. Cracks and corrosion can cause electric shock.
- ★ Charge in a well ventilated area unexposed to fire. Do not use the charger in highly humid areas or in an area exposed to rain and snow moisture or other kinds of moisture.
- ★ Use in an ambient temperature range of 0 to 40°C. Do not store the charger in an especially hot area.
- ★ If the plug is loose it might get hot and cause a fire.
- ★ Before charging, check whether the battery fluid is within the proper fluid level range. If the fuel is low, be sure replenish it. (14-4 page)
- ★ When charging hang a tag that reads "Open flame prohibited".
- ★ Charge the battery with the battery cap tightened to prevent the top of the battery from being contaminated.

DESCRIPTION OF EQUIPMENT FOR BATTERY DRIVE

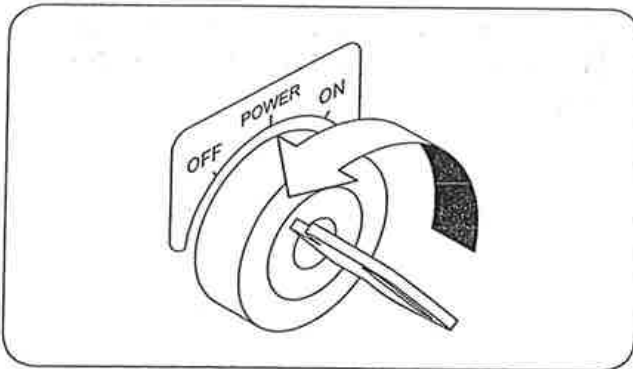

◆ **Charging procedure**

1 Check that the power switch on the electric power unit is turned OFF.

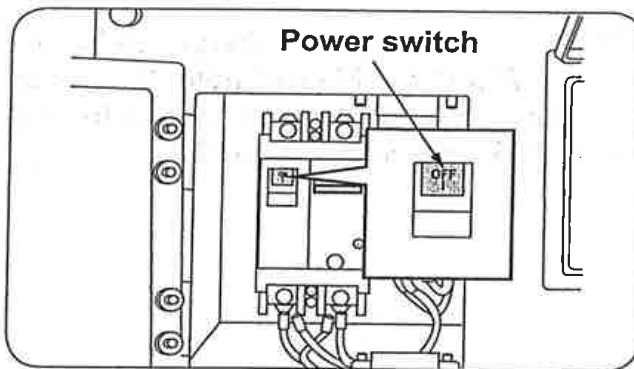

2 Check that the power switch on the charger is turned OFF.

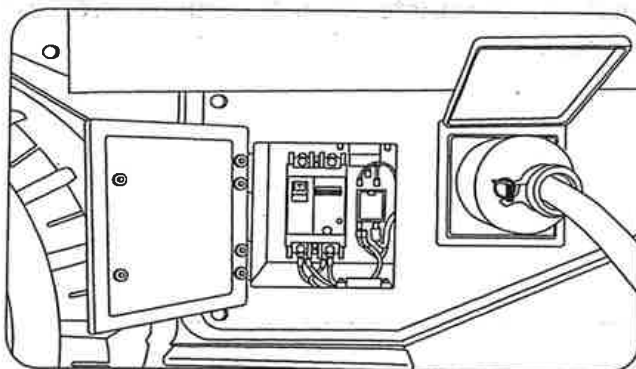

3 Connect to the power plug for the charger in the wall outlet.

4 Open the charging port cover of the electric power unit and connect the charging plug to the charging port.

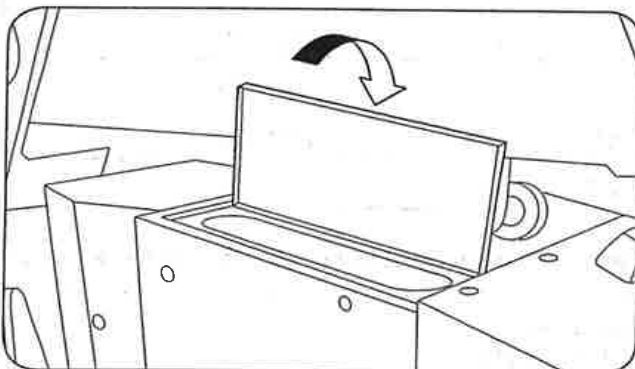

5 Open the ventilation window on the cover on top of the battery.

DESCRIPTION OF EQUIPMENT FOR BATTERY DRIVE

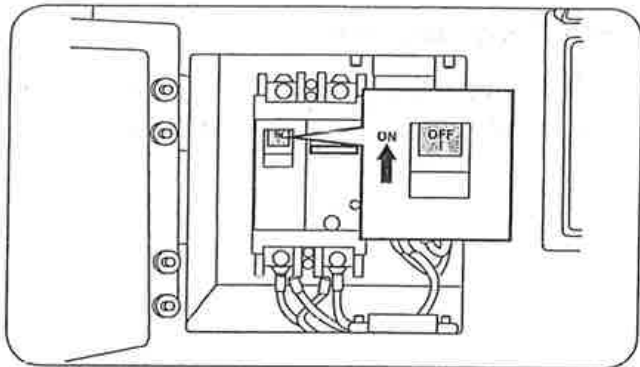

6 Turn the power switch for the charger ON. The LED lights and charging begins.

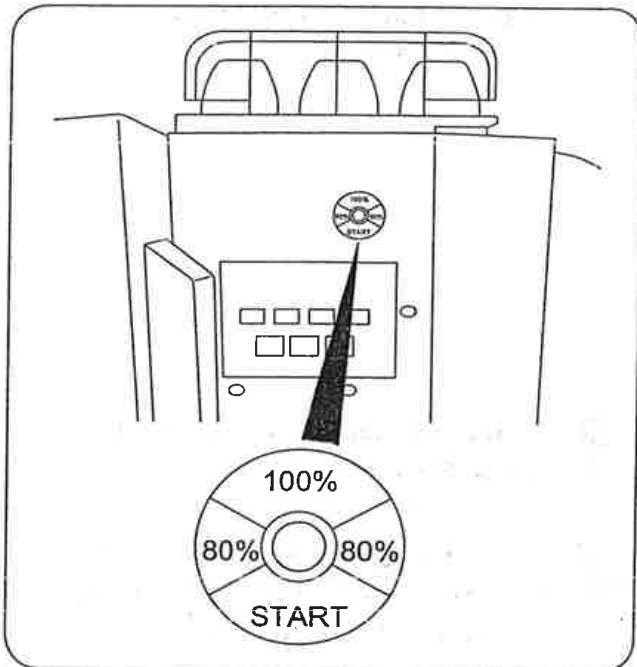

7 When a normal charge ends, the YELLOW LED will light. When performing a normal charge, charging finishes roughly 5 hours after it starts.*1

8 A full charge takes a further 5 hours to complete from the end of normal charge.*1

Charger status	LED color
Charger power OFF	Extinguished
Charging	RED
Normal charge complete (80%)	YELLOW
Full charge complete (100%)	GREEN

***1 The charge time depends on the battery level.**

⚠ CAUTION

★ If you want to stop in the middle of charging, Turn OFF the power switch for the charger and check that the LED is off. Then, unplug the charging plug.



DESCRIPTION OF EQUIPMENT FOR BATTERY DRIVE

9 Once the charge is complete, turn the power switch for the charger OFF.

10 Unplug the charging plug for the charger and shut the charge port cover and ventilation window.

11 Unplug the power plug for the charger.

If you want to terminate charging in the middle of charging, perform steps 9 through 11. Perform a full charge once a week. In addition, if the battery is left unused for a long period of time, its voltage drops due to self-discharge. Fully charge the battery about once a month even if you do not use it.

 **CAUTION**

★ Open and shut the inspection port on top of the battery several times after charging (before starting work) to allow the hydrogen gas to diffuse as there is a risk of explosion of the hydrogen gas emitted during charging. Also, if charging indoors open a window or door to allow air to circulate.

★ Remove the charger from the wall outlet when you are not using the charger.

★ Should a failure or abnormality occurs, stop using the charger immediately and call your designated Unic service facility. Talk with your designated Unic service facility for inspection, adjustment, and repair matters as well.

DESCRIPTION OF EQUIPMENT FOR BATTERY DRIVE

4 Operating Instructions

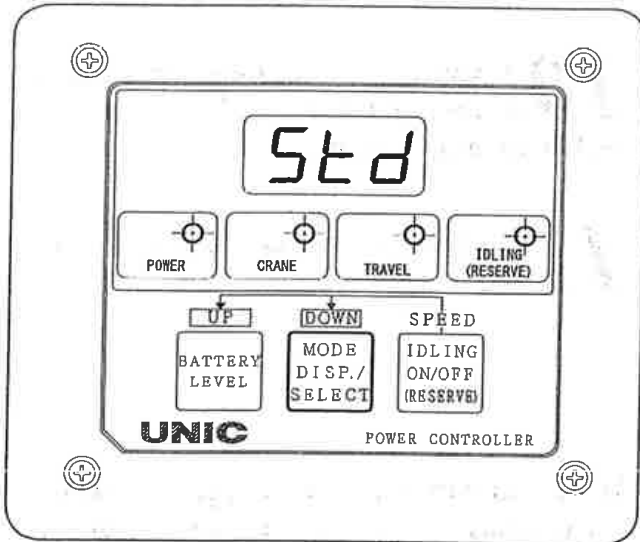

◆ 1. Switching operation modes

The main unit can be switched between two operation modes enabling it to be used properly for a certain task.

When the operation mode display/select button is pressed, the current operation mode is displayed. If you press it again while the operation mode is being displayed, the mode changes. Two seconds after pressing the button, the screen returns to the normal screen.

- Standard operation mode

An operation mode for standard settings. It displays the rated performance. The display is "Std".

- High-speed operation mode

This mode is used when you want to operate at a higher speed than the standard mode. The display is "H!".

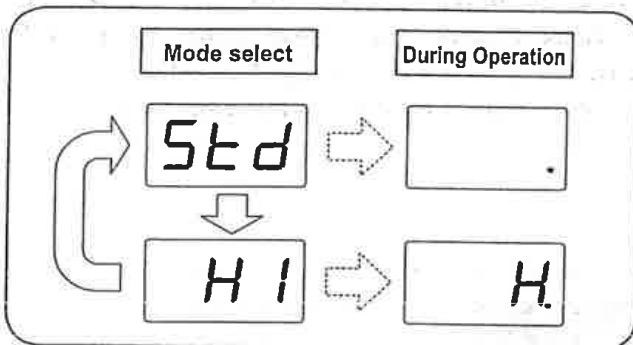

⚠ CAUTION

★ In the high-speed operation mode, the battery will be depleted faster than when in the standard operation mode.

★ When the battery voltage drops, the mode is forcibly switched to the standard operation mode to protect the battery and then, the high-speed mode becomes inoperable.

Charge the battery when you use the high-speed specification mode again.

DESCRIPTION OF EQUIPMENT FOR BATTERY DRIVE

◆ 2. Idling mode

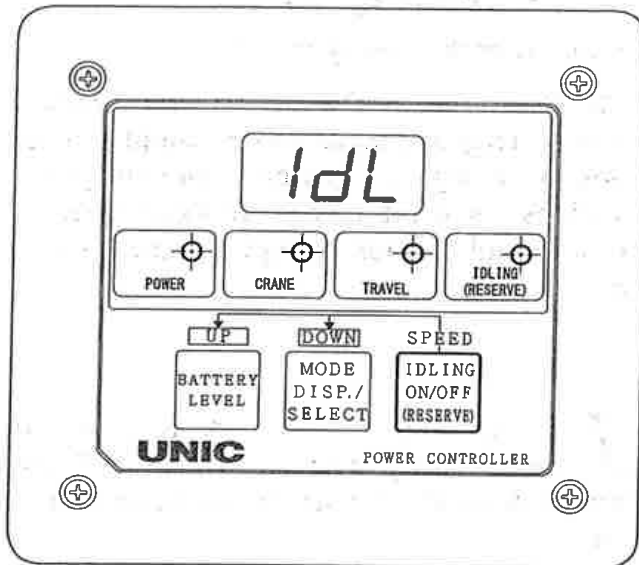

In this mode the motor runs at a fixed rpm. It is used when the motor is required to be run such as when doing maintenance.

When the idling ON/OFF button is pressed "IdL" appears, a set speed is then displayed and the motor begins to run.

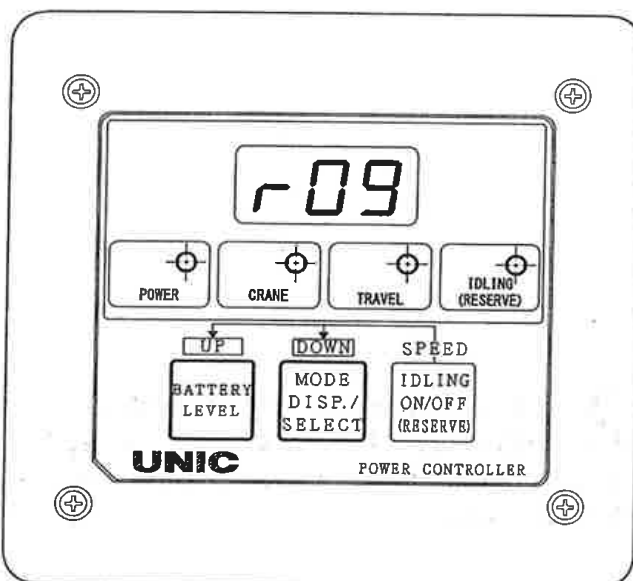

• Rotation speed adjusting

The rotation speed can be adjusted by pressing UP (Battery level button) or DOWN (Operation mode button).

The "Std" and "Hi" settable speeds range from 700 rpm to max. 2200 rpm respectively. The display is "r07~r16, r18, r20, r22".

If the idling ON/OFF button is pressed again while in the idling mode, the idling mode ends.

• Battery level check

When BATTERY LEVEL is pressed, the battery level is displayed.

The display appears for 3 seconds.

CAUTION

★ When the battery level is displays "End" or is at "End." idling mode is unavailable.

DESCRIPTION OF EQUIPMENT FOR BATTERY DRIVE

◆ 3. Reserve mode (Emergency use)

- Run when the battery is depleted

The "Reserve mode" provided with the crane is an emergency measure that supplies temporary emergency power in an emergency such as when the power runs out during a task at a job site rendering the crane immovable.

1 If the battery level drops and the remaining power is less than 10%, the battery level flashes across the mode indicator.

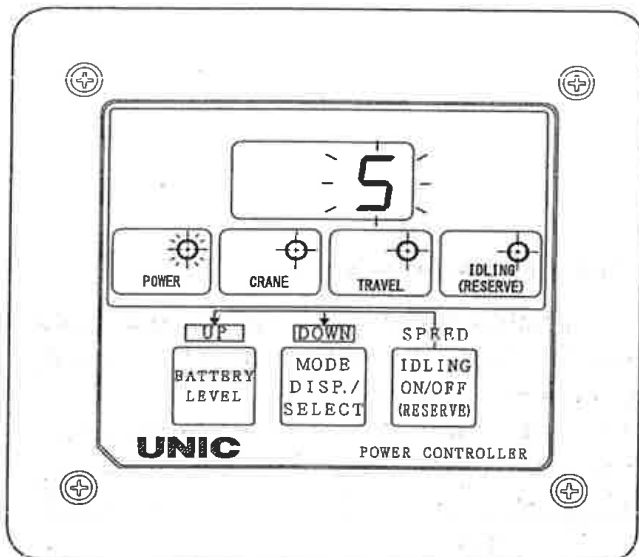

2 If crane continues to be used and the battery level reaches 0, "End." appears and blinks on the mode indicator and the crane stops.

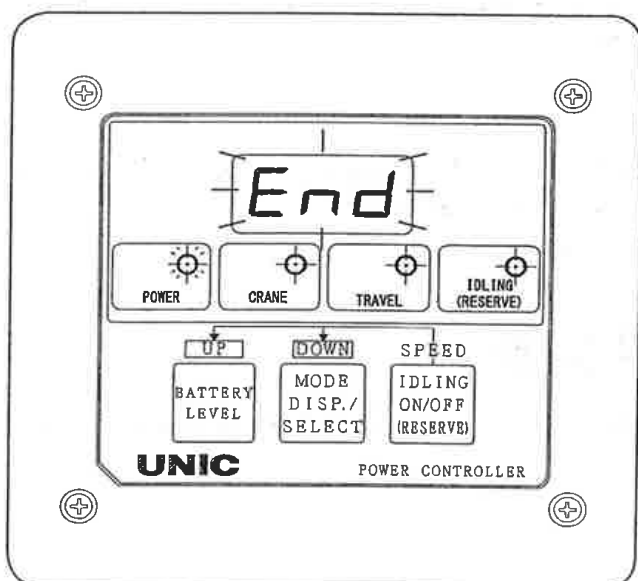

DESCRIPTION OF EQUIPMENT FOR BATTERY DRIVE

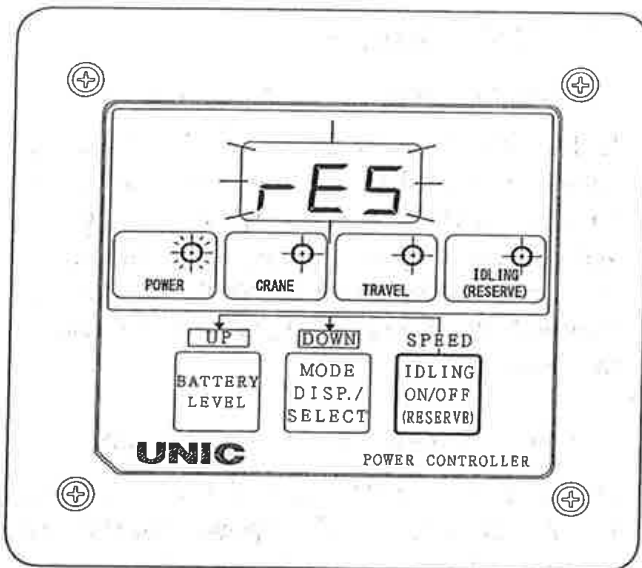

3 When transitioning to the reserve mode, hold down "Idling ON/OFF/reserve mode" for 5 seconds.

"RES" will appear and blink on the mode indicator indicating that the reserve mode is active.

● Remarks

- In the reserve mode the speed will be significantly reduced.
- The standard duration time for the reserve mode is about 30 minutes.

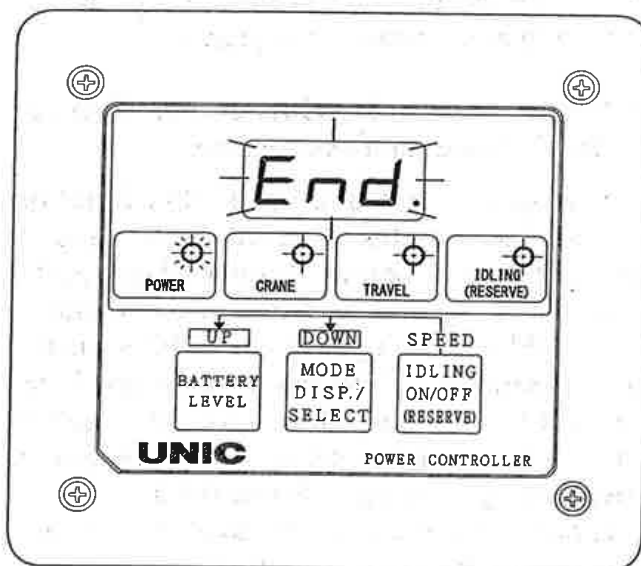

4 If the amount of power in the reserve mode runs out, "End." lights up on the screen and the crane goes into an all-stop state. To use the crane again turn the power off and charge it.



CAUTION

★ Excessive discharging places a heavy burden on the battery and may have an adverse effect on the life of the battery. Keep the battery level above 10% as much as possible.

★ The reserve mode is a temporary power supply mode used for emergencies. Charge the battery immediately after all necessary work is complete.



DESCRIPTION OF EQUIPMENT FOR BATTERY DRIVE

◆ 4. Other functions

- Contactor automatic stop function

If the crane is not operated for 2 minutes, this function stops the contactor (the main power for the motor control circuit) in order to conserve power. If you operate radio remote control or operation lever while the contactor is stopped, the contactor activates and you can move the crane.

- Crane automatic power stop function

If the crane is not operated for 30 minutes, this function shuts off the power for the crane to prevent operation mistakes. During crane automatic power stop "SLP" appears and blinks on the mode indicator. The crane is incapable of being moved even if operated with the radio remote control or operation lever. Restart the power of the electric power unit so that the crane moves again.

- Automatic speed reduction function for electric power unit overheating

If the power unit overheats, this function lowers the operational speed of the crane so the power unit can cool down. During the automatic speed reduction due to overheating, "Hot" appears and blinks on the mode indicator. If the temperature continues to climb, the crane shuts down as a safety measure. When the crane is stopped due to overheating, "Hot" is displayed.

When the temperature of the electric power unit drops, the speed reduction is cancelled.



DESCRIPTION OF EQUIPMENT FOR BATTERY DRIVE

- Automatic speed reduction when the battery charge drops.

The remaining battery capacity of the power unit is reduced, the operating speed of the crane will be reduced because of the warning. During the automatic speed reduction due to reduced battery level, the battery level appears and blinks on the mode indicator.

Display	Action	Description
10~1	Speed reduction	The battery level has reached 10% or less.
End	Unit shuts down	The unit is stopped due to the battery depletion. Charge the battery.
rES	Reserve mode (Significantly slower speed)	If you press and hold the idling button for 5 seconds when "End" is being displayed, emergency power will be supplied.
End.	Unit completely shuts down	The power level for the unit is completely depleted. Charge the battery.

- Warm up function

This mode raises the temperature of the internal substrate to preserve the circuits when in low temperature operating conditions.

In this mode, the radio remote control and operation lever cannot be used.

During warm up "d+remaining warm up time" is displayed on the mode display screen.

* Warm-up function operating temperature reference: -35°C



DESCRIPTION OF EQUIPMENT FOR BATTERY DRIVE

**◆5. Mode display when there is an equipment emergency
(sub-control box)**

Error number	How to reset	Radio remote control operation	Manual operation
E 13	The emergency stop button is pressed or the voltage of the battery is low. If the emergency stop button is pressed, release it and turn the power on again. If the emergency stop is not pressed, turn off the power and charge the battery.	×	×
E00 E 16 ~ E 17	The internal temperature is abnormally hot. Turn off the power, wait for a while and then turn it back on.	×	×
E07~E09 E 12 E20~E23 E32 E38 E47~E48 E52	Error signals are output from the inverter. Turn off the power and then turn it back on. If there is no improvement, check with your service center.	×	×
E 39	The capacitor is hot. Wait for a while and then turn the power back on.	×	×
E 93	There a possibility that an authentic inverter is not installed. Check with service center.	×	×
E 94	The lever was operated during the 3-second initial check. Turn the power off and then turn it back on.	×	×
E 95	The voltage of the battery is low. Turn off the power and charge the battery.	×	×
E 96	Crane power is turned ON during charging. Turn off the charger and disconnect the cable for the charger.	×	×

11. HOW TO OPERATE CARRIER

1 Designation of each control lever and its location

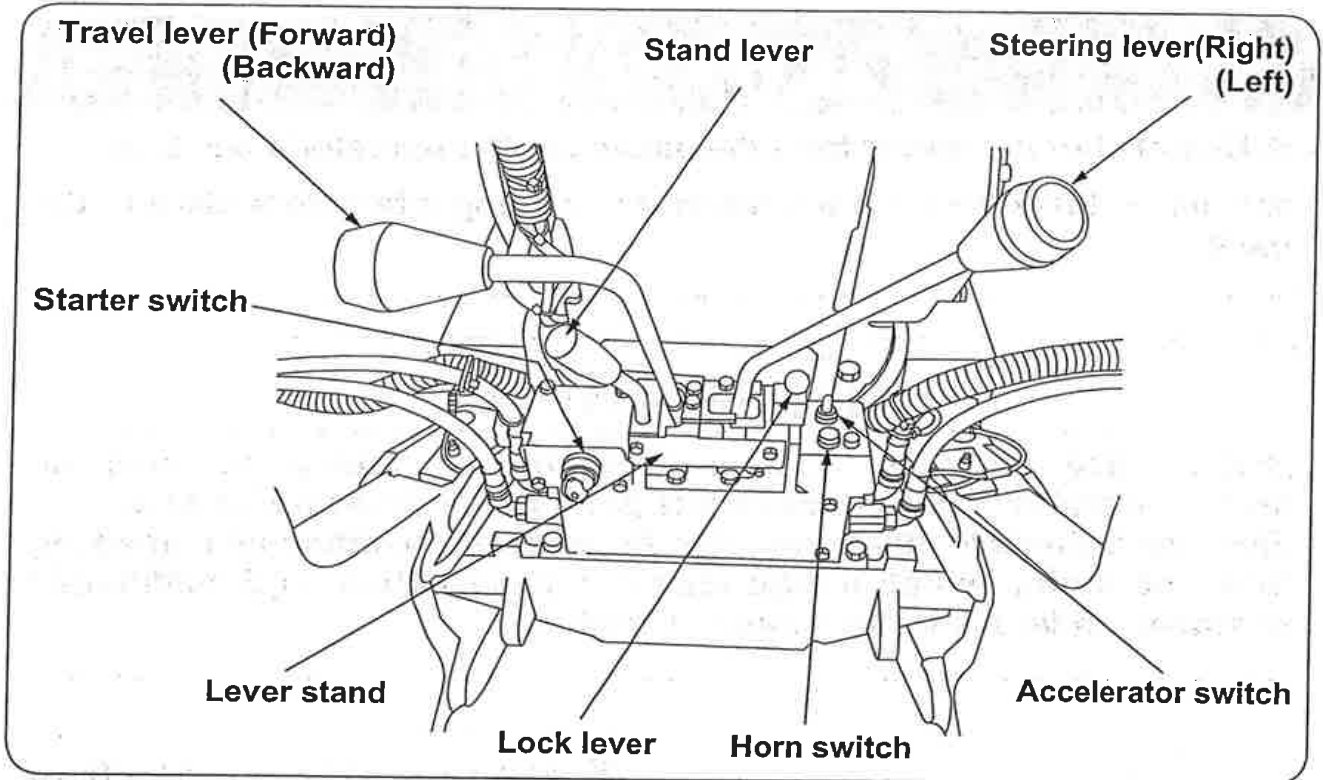

HOW TO OPERATE CARRIER

2 Preparation before operation

WARNING

- ★ Do not start the motor from the outside of the operator's position.
- ★ Confirm the safety around the crane working site before starting the motor.

CAUTION

- ★ Heavy-duty operation of the crane during an initial period after the start of operation may deteriorate its performance in a shorter time. Take approximately 100 hours after the start of operation as a breaking in period during which abrupt start and acceleration, and continuous operation under heavy load must be avoided.

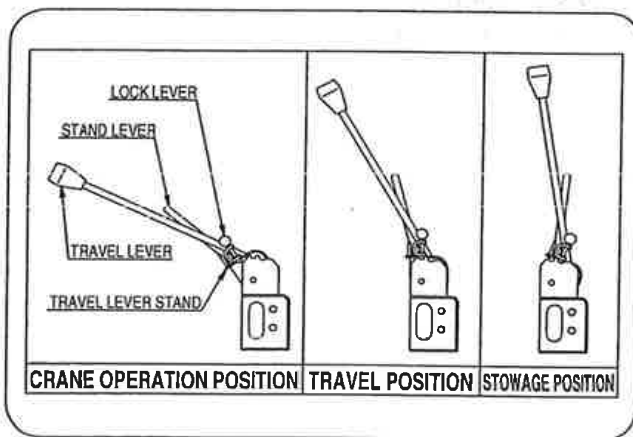

- 1** Shift the travel lever stand to "Travel" position.
- 2** Make sure that travel lever and steering lever are at their neutral positions.
- 3** Confirm that the machine is at travel posture.

- Boom is lowered to its extreme.
- Outriggers are stored.
- Hook is stored.

HOW TO OPERATE CARRIER

3 How to operate

! WARNING

- ★ Be sure to repair whenever found anything unusual.
- ★ Be sure to stop the motor before charging.

◆ 1. Starting power unit

- Starting in normal condition

1 Insert the key into the starter switch and turn it to ON position.

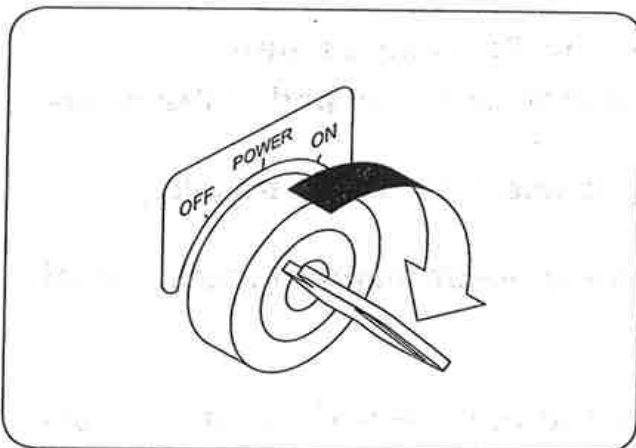

! CAUTION

★ After the power is turned on the crane runs a system diagnostic for around three seconds. Do not operate the crane during this time. If the crane is operated during the system diagnostic, "E.54" lights and crane operation becomes inexecutable.

In this instance, turn on the power once more. System diagnostics will be performed again.

★ If used in cold climates, it is best to enter into warm mode immediately after the power is turned on.

Do not operate the crane until after it is warmed up.



HOW TO OPERATE CARRIER

4 *How to Travel*

! WARNING

- ★ Start the crane traveling after the safety around the crane has been confirmed and make a sign when starting the crane traveling.
- ★ Carry out traveling operation by standing in front of the travel lever.
- ★ Keep anyone away from the crane.
- ★ Do not travel the crane with someone or an object mounted on the crane.
- ★ Arrange those who guide at a place where it may be unsafe and you have a blind spot.
- ★ Travel the crane as slowly as possible while making a turn.
- ★ If traveling backward, watch where it is to be travel and restrain traveling speed.
- ★ Run the crane slowly when making a sharp turn and traveling on a rough road.
- ★ Before leaving the crane, shift the travel lever stand to storing position and stop the motor.
- ★ Avoid running over obstacles.
- ★ If it is unavoidable, travel at low speed and keep the crane to lean less than 10° to the side.
- ★ When parking the crane on the street is unavoidable, set up safety devices such as a sign, a barricade, and a blinking light so that passing of other vehicles and pedestrians may not be disturbed.
- ★ Put a pallet against the rubber tire when parking the crane for a long period of time.
- ★ Do not park the crane over a place where withered grass or straw, which is flammable.
This many cause a fire by heat of exhaust pipe or exhaust fume.
- ★ When traveling the crane on a water filled area, observe to travel it within allowable depth of water.
Allowable depth: Up to the center of traveling motor or of tire.

HOW TO OPERATE CARRIER

◆ 3. Travel mode switching

• On road mode

This mode is used when traveling on a smooth road surface such as a paved road or indoors.

The crane is furnished with hydraulics to balance the speed differences of the inner and outer wheels during turns allowing the crane to travel smoothly.

• Off-road mode

The crane is furnished with independent hydraulics for the left and right wheels allowing the crane to travel with stability even on rugged roads.

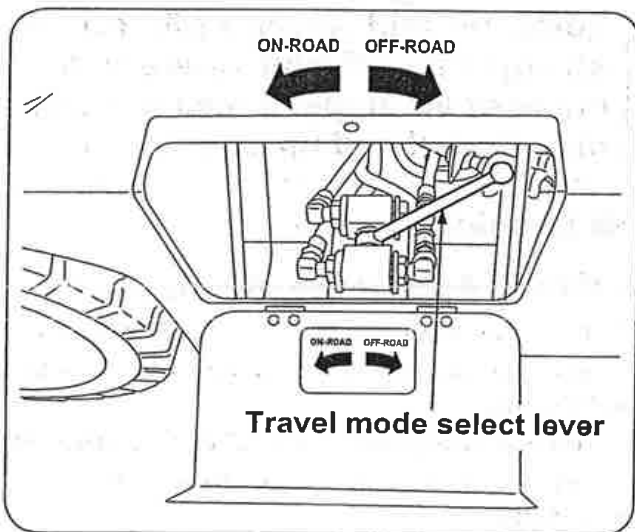

◆ 4. Switchover procedure

1 On the vehicle's left side, remove the thumbscrew of the travel mode select lever containing the tire guard to open the cover.

2 Move the select lever to the right to turn off the OFF ROAD mode. Move it to the left to select to the ON ROAD mode.

3 Close the cover and screw the thumbscrew back in place.

⚠ WARNING

★ To switch to the travel mode, check that the motor has stopped and then place the travel lever stand in the stowed position.

12. HOW TO OPERATE CRANE

1 Designation of each control lever and location

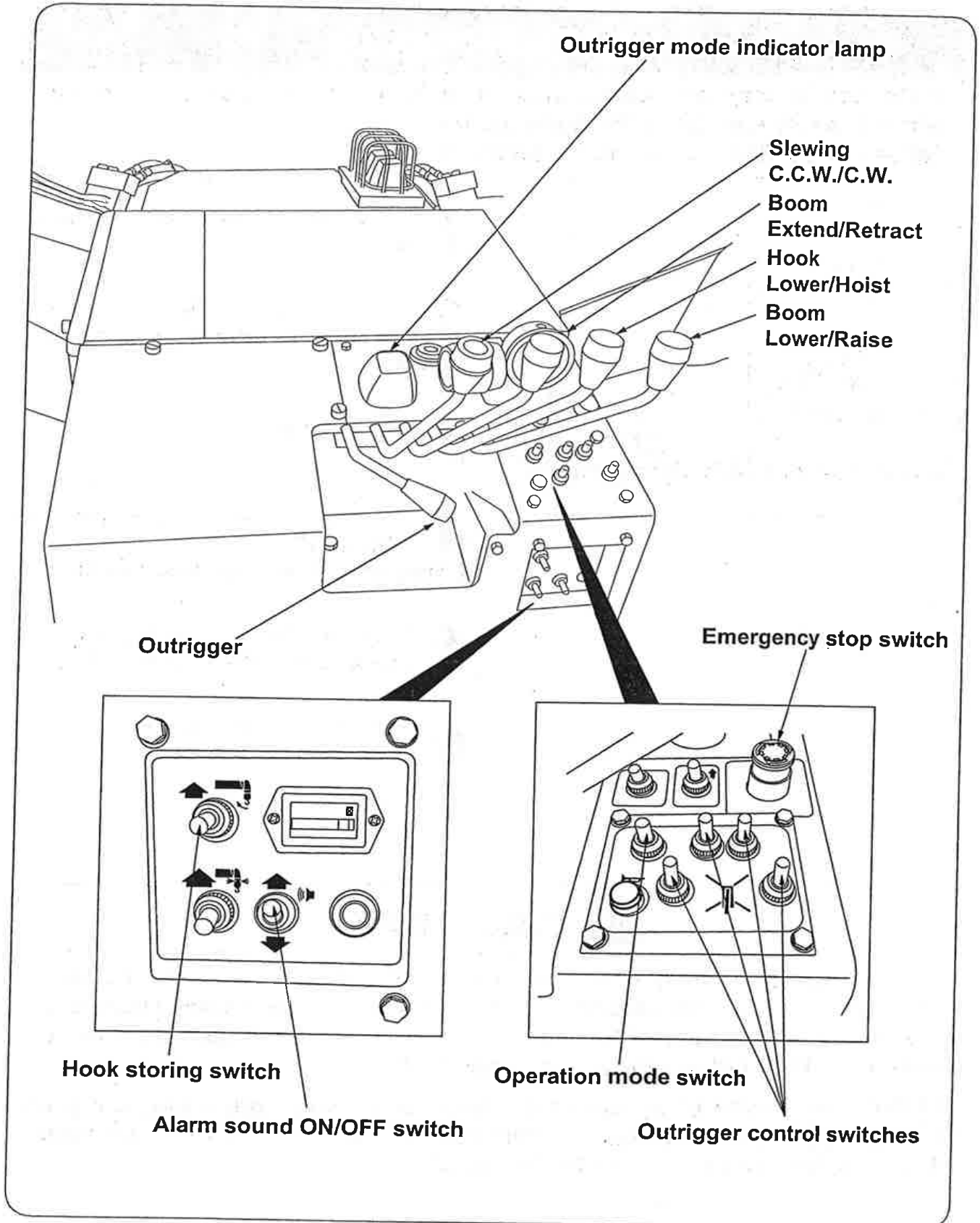

HOW TO OPERATE CRANE

2 Preparation before operation

WARNING

★ Do not let anyone stand under or in front of the hook as it swings when it is released from the hook holder. Failure to do this may invite an accident.

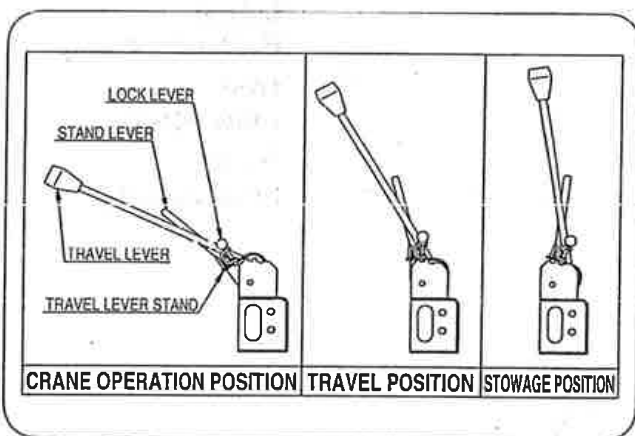

- 1** Set the travel lever stand to "Crane" position.
- 2** Make sure that each lever for controlling crane and outriggers is at its neutral position.
- 3** Turn on the power.
- 4** Turn the operation mode switch to "Outrigger".
(Outrigger mode indicator lamp lights.)
- 5** If the turnover prevention device is equipped, turn ON the alarm switch.
- 6** Turn ON the alarm sound switch.

CAUTION

★ In winter time, do not rush to operate the crane even after the steps illustrated above, preparation before operation, have been completed. Run the hydraulic pump for a while to warm it up. Execute the warm up operation in the idling mode. (on page 10-9)

★ Since viscosity of hydraulic oil is too high when the oil temperature is low, high-speed running of hydraulic pump fails the oil to be circulated so that the pump may be damaged.

3 Procedures to set up outriggers

WARNING

- ★ Crane operation without setting up the outriggers is strictly prohibited.
- ★ Do not operate the crane and extend the vertical cylinders and inner boxes while outriggers have been stored.
- ★ When setting up the outriggers on a rough ground or on a slope, be sure to place a support (such as plank, steel plate etc.) under the outrigger foot flanges to keep the crane level.
In addition, when the crane is to be operated on a soft ground, take the same measures to prevent the outrigger foot flanges from sinking into the ground when a cargo is lifted up.
Setting up the crane on a ground where it is not solid and firm enough may cause it to be overturned.
- ★ Do not put your foot under the outrigger foot flange while outriggers are being extended.
It may invite such accident as that the foot may be crushed by the outrigger.
- ★ Operation with the crane kept leaning makes it unstable when a cargo is lifted up.
Such operation can cause the outriggers to be damaged and the crane to be overturned.
- ★ The rated load is to be changed according to how far (maximum, half-way, minimum) the outriggers are extended.
Be sure to consult the “sticker concerning PROHIBITED AREA OF CRANE OPERATIONS” for the rated load corresponding to each extension.
- ★ In normal crane operation, set up the crane level on a solid and firm ground with the outriggers fully extended and lift up the crane body by approx. 50mm above the ground.
- ★ When outriggers are extended or being stored, be sure to insert the set pins so that the outriggers may not be rotated unexpectedly.
- ★ When extending outriggers, extend the inner boxes and allow them to touch the ground by using the vertical cylinders.
- ★ Be sure to touch the outriggers to the ground, as the crane may sink into the ground naturally if they are detached away from the ground.

HOW TO OPERATE CRANE

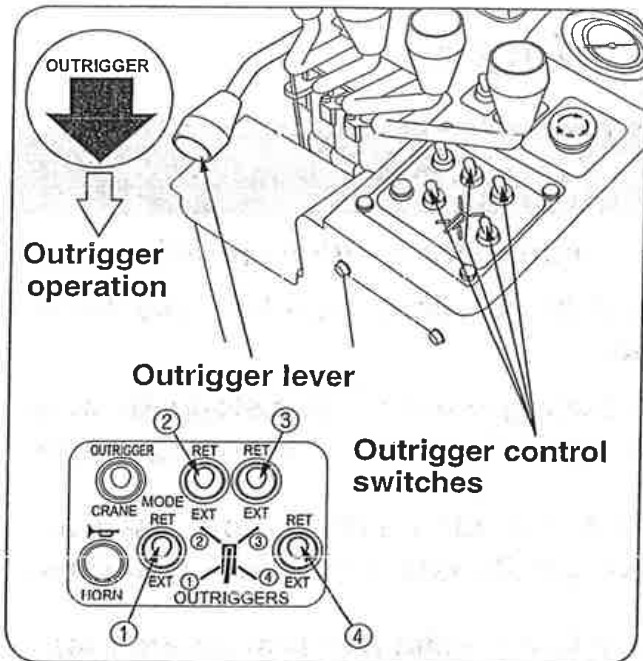

There are four (4) outrigger control switches and each switch is numbered. Select an outrigger control switch to throw it to desired function and operate the outrigger lever accordingly.

Set up the outriggers as follows:

1 Extract the outrigger set pin and insert it in appropriate place while referring to the sticker "PROHIBITED RANGE OF CRANE OPERATION".

2 Remove the lock pin (1) in the arm and hold the knob of outer box firmly to lift it up. Insert the lock pin and retain it with a stopper pin.

3 Remove the lock pin (2) to pull out the inner box. Insert the lock pin (2) and retain it with a stopper pin.

4 Control each outrigger control lever to adjust that the crane body is raised by approx. 50mm above the ground and it keeps level by referring to a level.

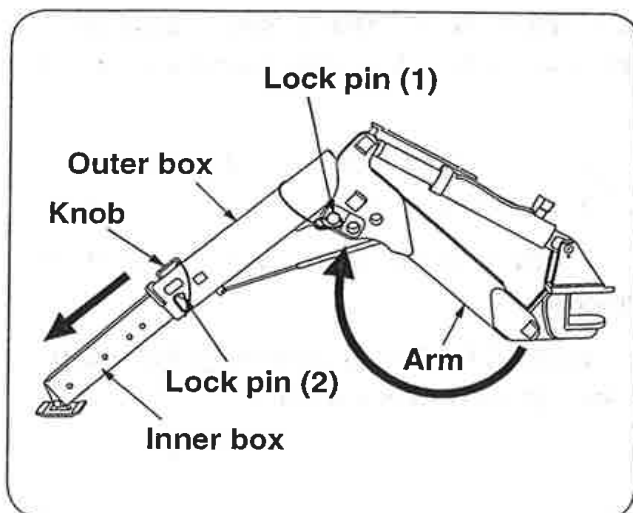
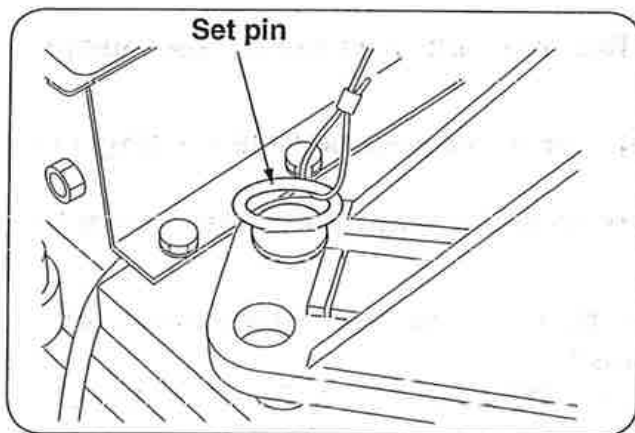

HOW TO OPERATE CRANE

! WARNING

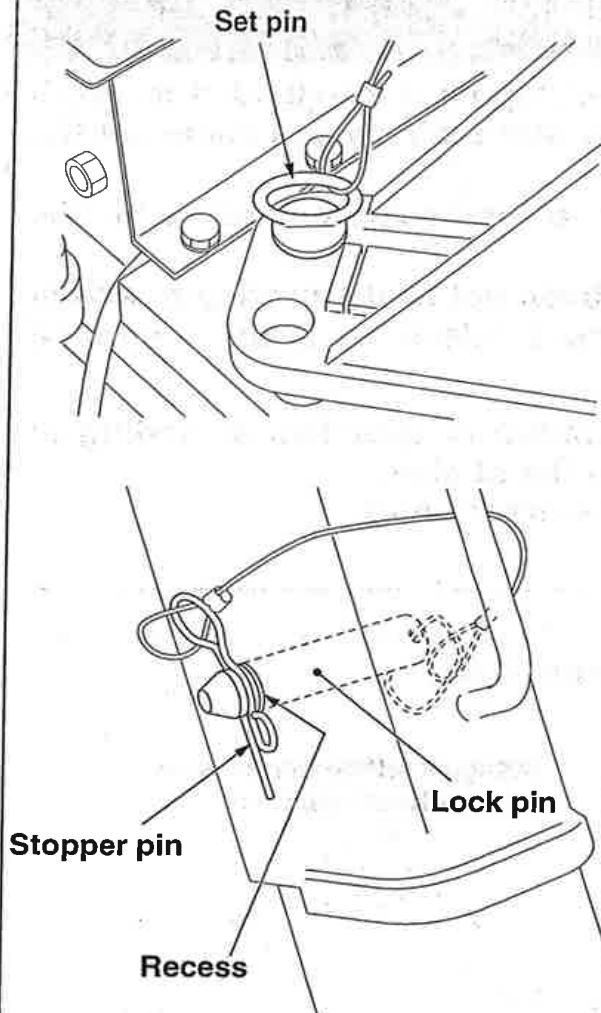

★ Insert each set pin securely when the outriggers are being stored and set up on the ground.

★ Insufficient insertion of the set pins allows them to come off which in turn may make the crane to lose balance causing the crane to be overturned.

★ After the lock pin has been inserted, be sure to put the stopper pin in the recess to retain it securely.

If neglected, the lock pin gradually escapes during crane operation which in turn causes overturn.

! DANGER

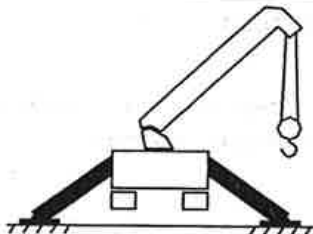

★ Before operating the crane it is mandatory to set up all the outriggers.

HOW TO OPERATE CRANE

◆ Extension of outriggers and rated load

! WARNING

★ Rated load is expressed when the outriggers are extended to maximum and to a distance below maximum with their spread angle set the same.

As a rule, set the outriggers extended to their extremes and with the spread angle of each 55° and 50°.

When any one of 4 outriggers has not been set to the maximum extension, the rated load other than maximum extension is to be applied which must be observed.

★ Since prohibited range of crane operation is specified according to spread angle of outriggers, confirm it on the sticker. If it is failed to observe, the crane may be overturned.

Outriggers extended to maximum

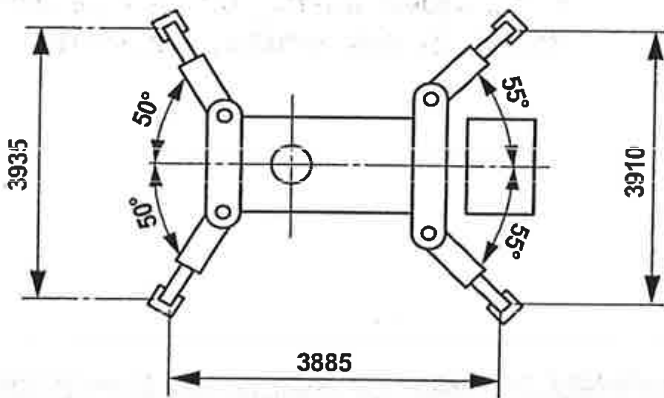

Outrigger setting with inner box extended to its maximum

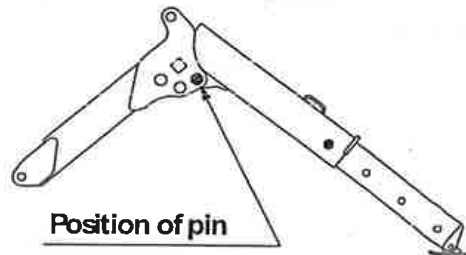

Example: Outrigger setting to a distance below maximum (Figure shows they are set to minimum extension).

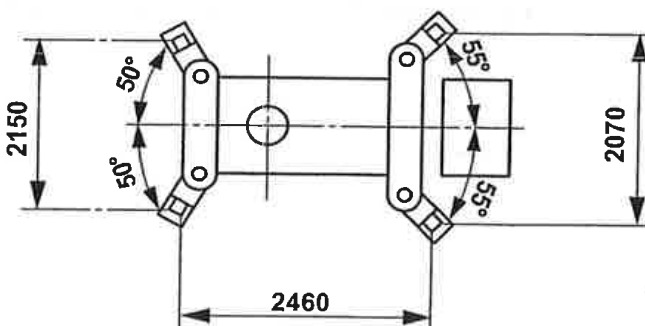

Outrigger setting with inner box pushed in to its minimum

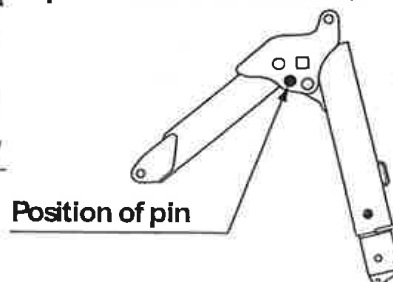

HOW TO OPERATE CRANE

4 How to operate boom for derricking
(raising and lowering)

! WARNING

★ An abrupt crane operation while a cargo is being lifted up gives an excessive shock to the crane which may cause the crane to be damaged or the crane to be overturned.

Be sure to control levers slowly.

★ The longer the boom is extended, the faster a cargo is lifted up and down by boom derricking operation.

Operate the boom so that a cargo can be lifted up slowly.

★ When lowering boom with a cargo hoisted, the working radius increases which in turn decreases the capacity specified in the rated load chart.

Check the readings of load indicator to confirm the safety before the boom is lowered.

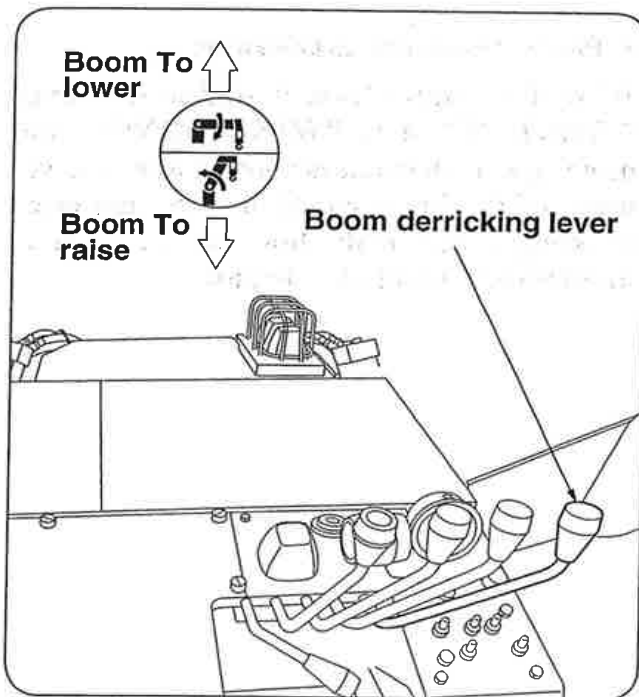

To raise

Shift the lever to "RAISE" to raise the boom.

To lower

Shift the lever to "LOWER" to lower the boom.

To stop

Return the lever to neutral position to stop the boom derricking.

◆ **Power automatic accelerator**

When the control lever is shifted further to "RAISE" or "LOWER", the motor speed increases according to the movement of the lever which in turn increases derricking speed of the boom as the lever is interlocked with the accelerator.

HOW TO OPERATE CRANE

5 *How to hoist and lower the hook*

! WARNING

★ Pay attention that the hook will not be over-wound. Be sure to turn ON the “alarm sound ON/OFF switch”.

★ If the hook hits against the boom top due to being over-wound of the hook, it may cause damage to the wire rope and the sheaves at the boom top and may cause the lifted cargo to fall.

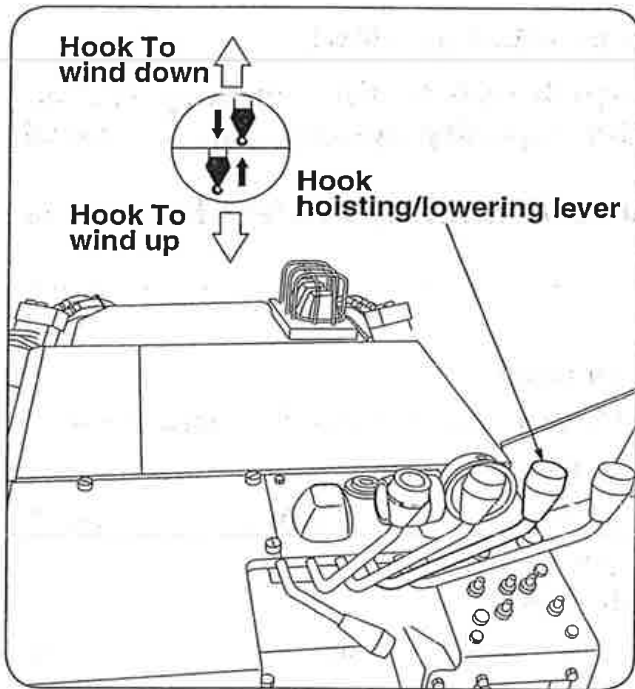

To wind up(raise)

Shift the lever to "UP" to raise the hook.

To wind down(lower)

Shift the lever to "DOWN" to lower the hook.

To stop

Return the lever to neutral position to stop the hook being wound up/down.

◆ **Power automatic accelerator**

When the control lever is shifted further to "WIND UP" or to "WIND DOWN", the motor speed increases according to the movement of the lever which in turn increases hoisting speed of the hook as the lever is interlocked with the accelerator.



HOW TO OPERATE CRANE

 **CAUTION**

★ Further paying out of the wire rope after the hook has reached the ground causes the rope to be irregularly wound around the drum. Lifting up a cargo with the rope irregularly wound on the drum damages the rope which results in remarkable shortening of its service life.

★ When paying out wire rope longer such as down to underground work site, make sure that more than 3 turns of wire rope shall always be left on the drum.

★ When the first layer of wire rope fails to be wound around the drum firmly and regularly, ropes wound over the first layer may dig into the inner layers to cause an irregular winding, When the wire rope is unwound to or wound up from the first layer of rope, wind it up/down slowly so that the first layer of rope can be wound around the drum firmly and regularly.

★ Stop the crane operation when hydraulic oil temperature exceeds 80°C.

Oil temperature is apt to rise easily if repeated operation of winding up/down of the hook, especially in a high lift, is carried out.

■ To know approximate oil temperature by sense of touch:

70°C	You can touch the oil tank (Lower part) with the palm of your hand for 3~4 seconds.
80°C	You can touch the oil tank (Lower part) with your finger tip for 1~2 seconds.
90°C	The moment you touch the oil tank (Lower part), you will let the hand off by reflex action.

HOW TO OPERATE CRANE

6 *How to telescope boom*

! WARNING

★ If the boom is extended further with the hook come close to the boom top, the hook may hit against the boom top causing the wire rope and the sheaves at the boom top to be damaged, and the fall of lifted cargo may result.

★ Be sure to turn ON the "alarm sound ON/OFF switch".

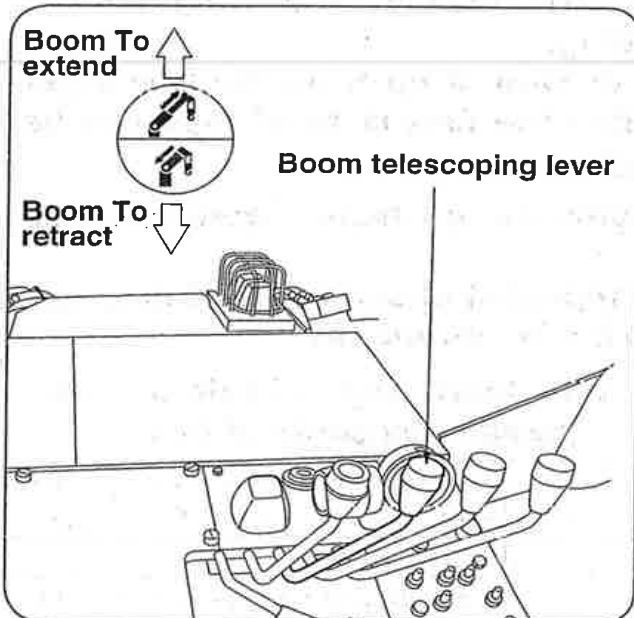

To extend

Shift the lever to "EXTend" to extend the boom.

To retract

Shift the lever to "RETract" to retract the boom.

To stop

Return the lever to neutral position to stop the boom telescoping.

◆ Power automatic accelerator

When the control lever is shifted further to "EXT" or "RET", the motor speed increases according to the movement of the lever which in turn increases telescoping speed of the boom as the lever is interlocked with the accelerator.

! CAUTION

★ The hook is lifted up as the boom extends and is lowered as it retracts.

When telescoping the boom, pay attention to where the hook is.

HOW TO OPERATE CRANE

7 How to slew boom

! WARNING

- ★ Carry out slewing operation slowly without raising the motor speed.
 - ★ Slewing without outriggers set up is strictly prohibited.
 - ★ Control levers slowly to allow the boom to make a smooth start and stop slewing.
- An abrupt lever control with a cargo hoisted allow it to swing which may cause hitting against the other objects and overturn of the crane.
- ★ The longer the boom is extended and the smaller the derricking angle becomes, the lifted cargo moves faster.
- Perform slewing operation slowly with the above in mind.

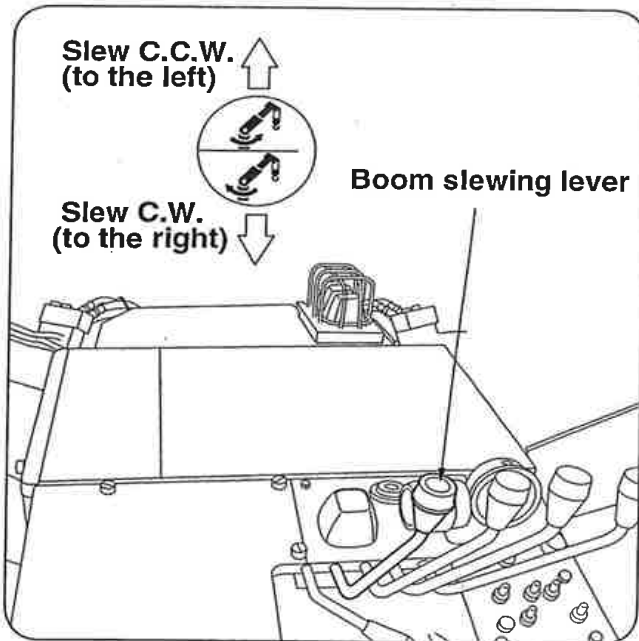

To slew to the right(C.W.)

Shift the lever to "↻" to slew it C.W..

To slew to the left(C.C.W.)

Shift the lever to "↺" to slew it C.C.W..

To stop

Return the lever to neutral position to stop the boom slewing.

◆ **Power automatic accelerator**

When the control lever is shifted further to "↻" or "↺" direction, the motor speed increases according to the movement of the lever which in turn increases slewing speed of the boom as the lever is interlocked with the accelerator.

HOW TO OPERATE CRANE

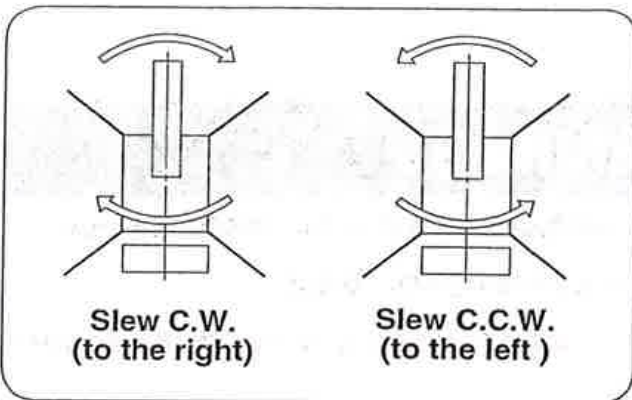

For slewing direction of boom, "slew to the right" means slewing in the direction as the hands of a clock rotate (C.W.) and "slew to the left" means slewing in the opposite direction of clock hands rotate (C.C.W.) when viewed over the crane.

CAUTION

★ Before starting the boom to slew, sound the warning horn to those who are attending or in the working site.

HOW TO OPERATE CRANE

8 How to store crane

! WARNING

★ Be sure to store the boom from the left hand side of the operator's position.

★ Be careful about the storing the crane and slow down operating speed as the distance between the boom and each control lever becomes close.

In addition, be sure to store the crane to observe the procedures as follows:

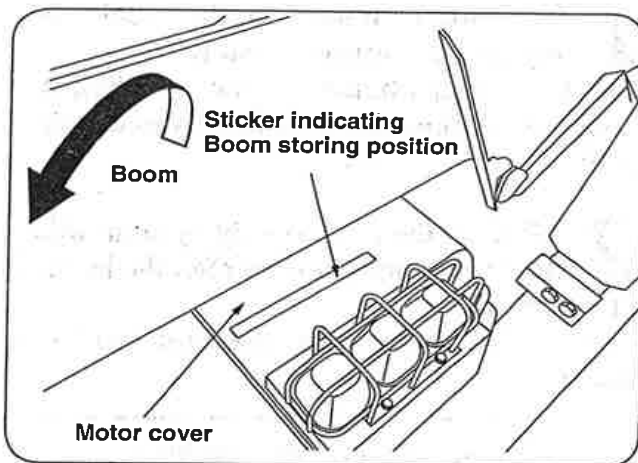

- 1** Retract the boom.
- 2** Slew the boom to a place close to the "sticker for boom storage".
- 3** Lower the boom to its extreme.
- 4** Position so that the side of boom of your side comes right over the sticker indicating storing position stuck on the motor cover.
- 5** Store the hook.

HOW TO OPERATE CRANE

9 *Procedures for storing hook*

! WARNING

- ★ Never try operating the crane by controlling the hook storing control switch as this is dangerous.
- ★ Store the hook after all boom sections have been retracted and lowered fully.
- ★ Do not operate the hook storing control switch and other control lever at the same time which may cause a malfunction and a breakdown.

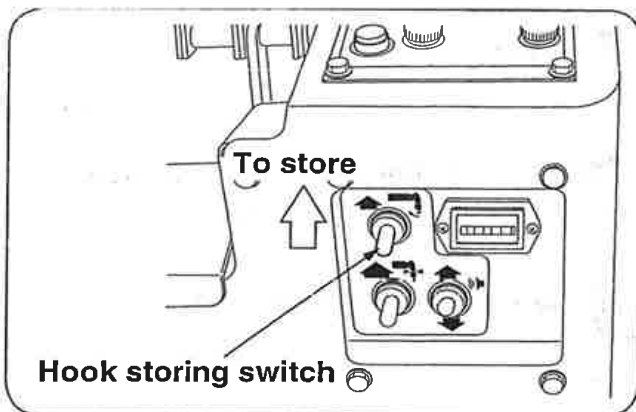

1 Hoist up the hook with the "hook storing switch" turned to "Store". The hook stops being wound up when the hook hits against the weight of over-winding alarm.

2 Wind up the hook slowly by controlling the hook storing switch after the hook is at a standstill. Release the switch after the hook has been stored.

! CAUTION

- ★ Storing hook while it is swinging may cause the boom, the hook, and the wire rope to be damaged.
- ★ Take care that the manual control lever for hoisting/lowering hook moves toward hoisting side when storing the hook.

HOW TO OPERATE CRANE

10 *How to store outriggers*

! WARNING

- ★ Start storing outriggers after the boom has been stored.
- ★ When storing outriggers, be sure to retract the inner boxes to their extremes after the cylinders have been fully retracted.
(It is very dangerous that inner box may fall by own weight unless the inner boxes are retracted after the cylinders have been fully retracted.)
- ★ When storing the outriggers, be sure to insert the set pins securely so that the outriggers may not be rotated unexpectedly.

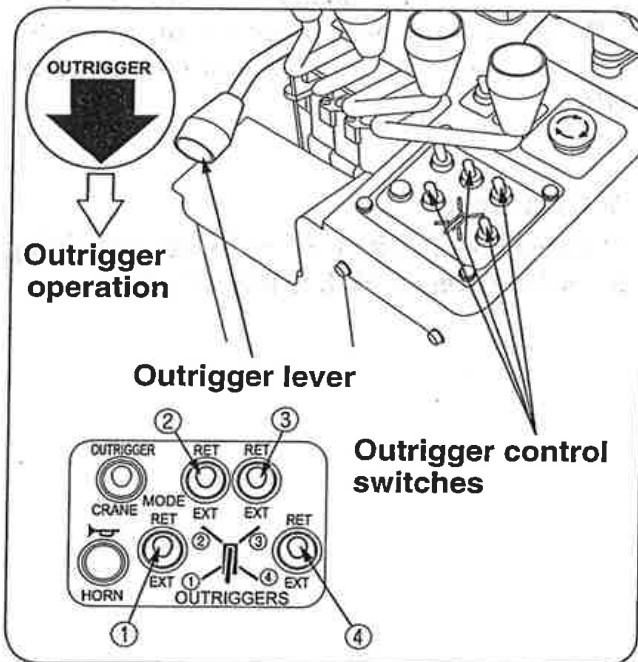

There are four (4) outrigger control switches and each switch is numbered. Select an outrigger control switch to throw it to desired function and operate the outrigger lever accordingly. Carry out each operation of the outriggers according to instructions on the sticker.

HOW TO OPERATE CRANE

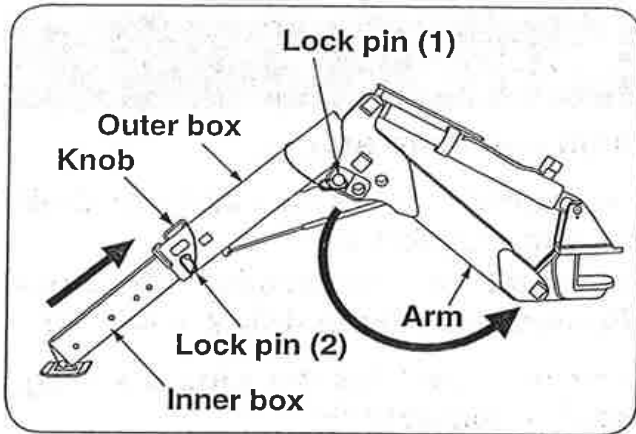

Store the outriggers as follows:

- 1** Retract the cylinders fully first to retract the inner boxes to their extremes.
- 2** Remove the lock pin (2), push in the inner box fully, and insert the lock pin (2) back again.
Retain the lock pin with a stopper pin.
- 3** Remove the lock pin (1) in the arm and hold the knob of outer box firmly to push it down strongly.
Insert the lock pin (1) and retain it with a stopper pin..
- 4** Remove the outrigger set pin and insert it securely in appropriate place so that the outrigger may not be rotated unexpectedly.

● Remarks

Outriggers may be lowered while traveling for a long time which is not a fault.

HOW TO OPERATE CRANE

11 *How to switch manual operation mode to/from radio remote control mode*

1 Put the traveling lever stand in the operating position of the crane.

2 Check that each lever for controlling the crane and the outriggers stays at its neutral position.

3 Turn on the power.

4 When operated in manual control mode, the outriggers and the crane can only be operated by manual control. No operation can be carried out through radio remote controller. The operation mode indicator lamp located on the top of cover will not be lit during manual control mode.

5 Push the mode selector switch to switch it to the radio remote control mode.

6 When it is switched to the radio remote control mode, the outriggers and the crane can only be operated through radio remote controller. Turn ON the radio remote controller to carry out remote control operation. The outriggers and the crane cannot be operated by manual control.

7 When switched to radio remote control mode, the operation mode indicator lamp located on the top of cover will be lit. The lamp should always be lit when operated on radio control mode.

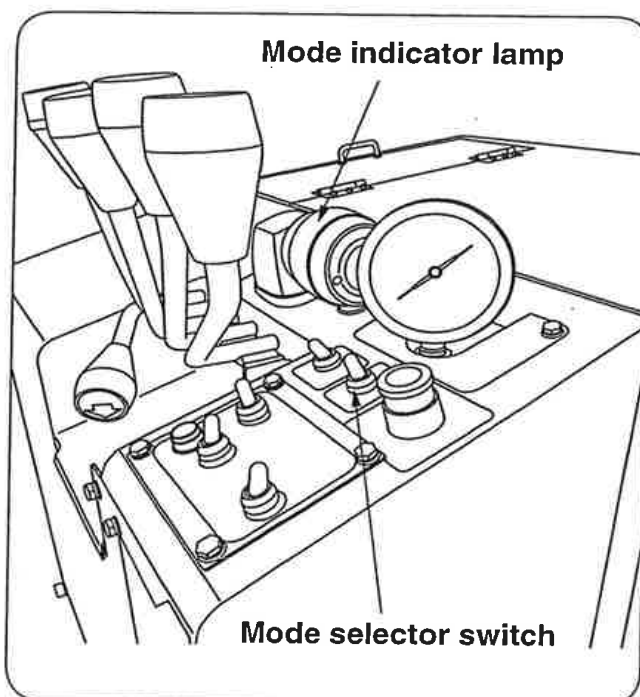



HOW TO OPERATE CRANE

CAUTION

★ The state of each operation mode will be maintained even after the power has once been turned OFF.

Check the operation mode and the operation mode indicator lamp when it has been re-started.

★ The operation mode indicator lamp functions according to each operation mode as follows:

Radio control mode : Operation mode indicator lamp lights.

Manual operation mode : Operation mode indicator lamp goes off.

HOW TO OPERATE CRANE

12 How to operate outriggers when in an emergency

! WARNING

- ★ Do not touch the motor, its cover with your bare finger/hand as they are very hot immediately after operation.
- ★ Be sure to put the cover back again after the outriggers have been stored.

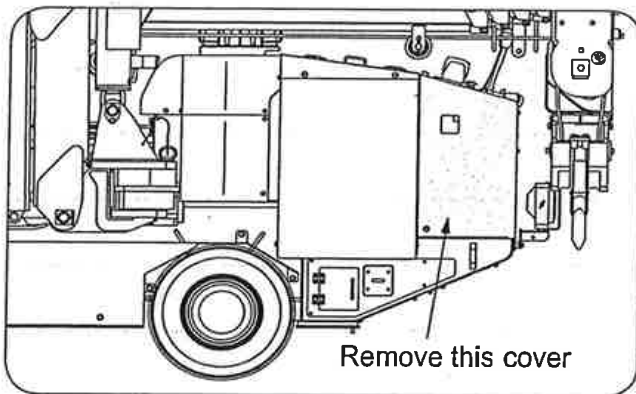

If outriggers fail to make a functioning correctly in normal operation, operate outriggers temporarily according to procedures illustrated below.

1 Remove the cover over the outrigger valves.

Remove the thumb-screws (7 places) to remove the cover.

2 Push the solenoid valve button of outrigger you want to operate with a bar such as screwdriver.

When the outrigger control lever concerned operates, the outrigger functions.

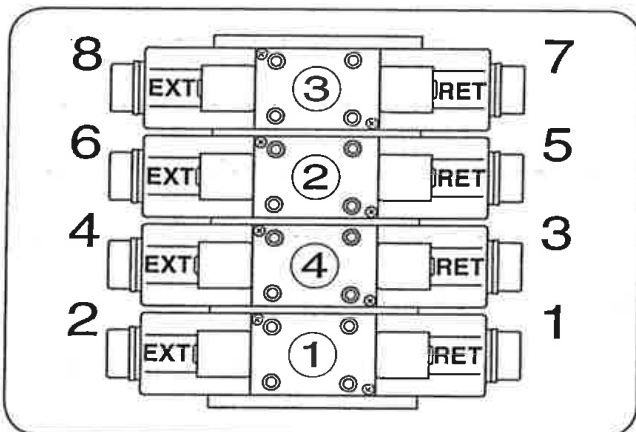

Outrigger to be operated		Operation
Outrigger ①	Retract	Operate lever with button 1 depressed
	Extend	Operate lever with button 2 depressed
Outrigger ②	Retract	Operate lever with button 5 depressed
	Extend	Operate lever with button 6 depressed
Outrigger ③	Retract	Operate lever with button 7 depressed
	Extend	Operate lever with button 8 depressed
Outrigger ④	Retract	Operate lever with button 3 depressed
	Extend	Operate lever with button 4 depressed

! CAUTION

- ★ While cover is being removed or when depressing a solenoid valve button, work carefully not to damage the electric wiring.
- ★ After the procedures have been completed, have the crane repaired by the nearest UNIC service shop.



MEMO



A series of horizontal lines for writing, starting with a solid line and followed by several dashed lines, providing a template for a memo.

13. U-WAVE, RADIO REMOTE CONTROL DEVICE

1 Request to those who operate the crane

This radio remote control device conforms to regulations for specified small power radio station in the radio wave law.

Use of U-WAVE, "specific low power type" interlocking radio control device, allows the crane operation that will hardly be influenced by radio interference compared with conventional radio remote controllers of weak radio wave type.

In addition, there is no need to get qualification, license, or registration in using the radio remote control device.

Read this manual carefully and understand the contents to use this device.

◆ When making inquiries

When making inquiries, be sure to inform us of model, serial number illustrated on the following label in the remote control transmitter.

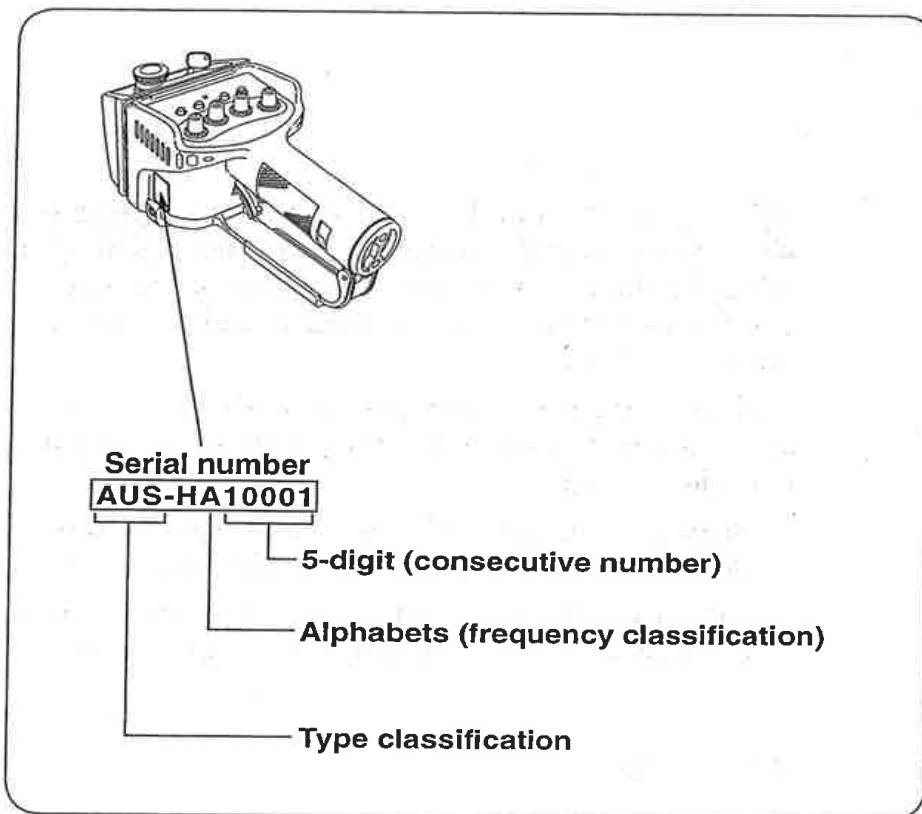

U-WAVE, RADIO REMOTE CONTROL DEVICE

2 Safety precautions

! WARNING

★ Observe the cautions for securing safety.
Failure to observe the cautions may invite troubles or serious accidents.

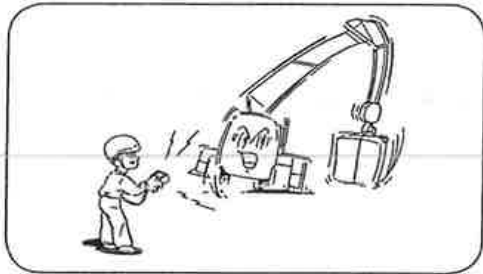

1 In case of crane operation through transmitter, pay attention to circumstances around the crane and to the safety especially for the crane that it will not to be overturned as the operator is to control the crane at a distance.

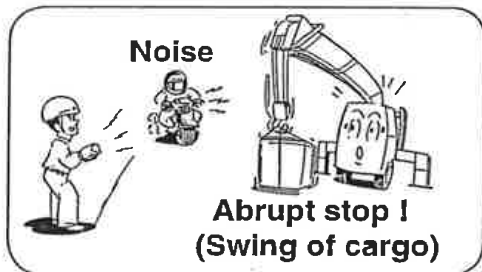

2 Pay attention to the swing of a lifted cargo as the crane may make an abrupt stop when operating it through radio remote control device because it may be affected by radio interference, radio jamming, and noise coming from outside.

In order for the crane system not to be affected easily by noise coming from outside, operate the crane with the following in mind:

- ① Operator must not leave the crane unnecessarily. Operate the crane within working radius of the crane.
- ② Correct or repair the transmission antenna (located at the stem of transmitter) if it has been distorted or damaged.

● **Remarks**

Typical source of noise interference:

- Ignition noise emitted from the engines such as of motorcycles or of portable generators.
- Buzzers using contacts such as for alarming when reversing vehicles.
- Electric motors of air-conditioner fan, electric fan, and flashing beacon mounted in cab compartment.

U-WAVE, RADIO REMOTE CONTROL DEVICE



8 Do not thrust the control panel in the transmitter and/or control keys with a sharp article as it may make a hole resulting in entering water inside through it.



9 Do not give the transmitter an abrupt temperature change. An abrupt temperature change may cause a fault due to building-up condensation inside of the transmitter.

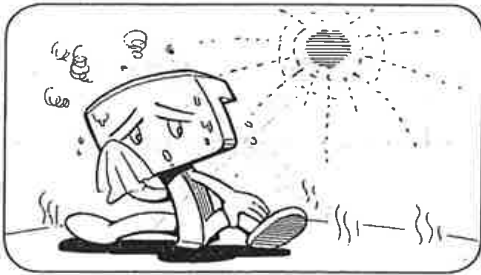

10 Do not put or store the transmitter where:

- It is exposed to direct sunlight,
- It is in front of hot air outlet exhausted out of the vehicle, and
- It is close to a heating apparatus or it is too humid.

U-WAVE, RADIO REMOTE CONTROL DEVICE

3 *Designation of each equipment*

◆ **1. Construction of radio remote control device**
(Showing typical mounting example)

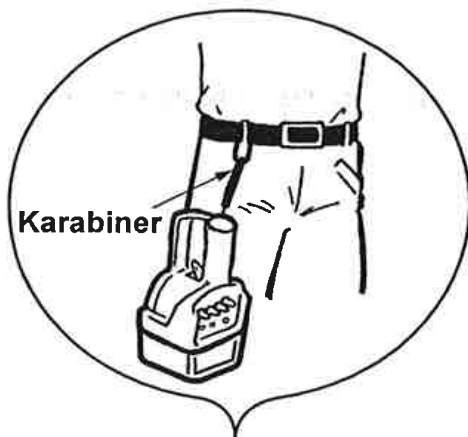
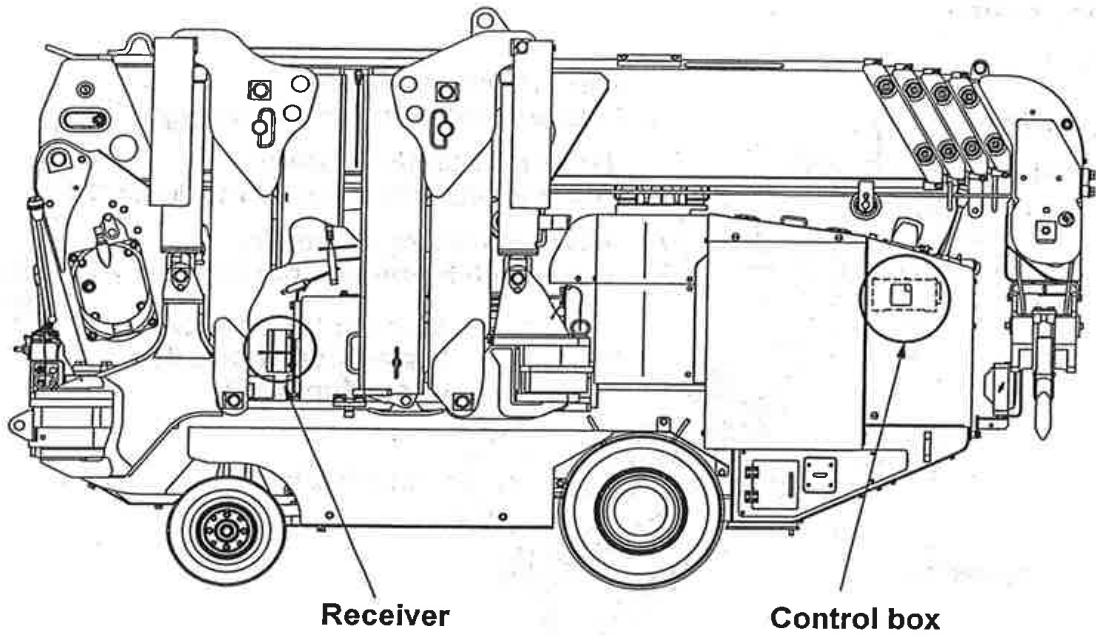

When hanging the transmitter
at your waist

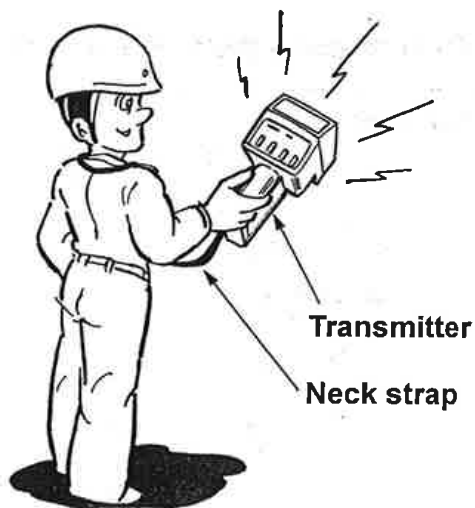

U-WAVE, RADIO REMOTE CONTROL DEVICE

◆2. Designation of each part of transmitter

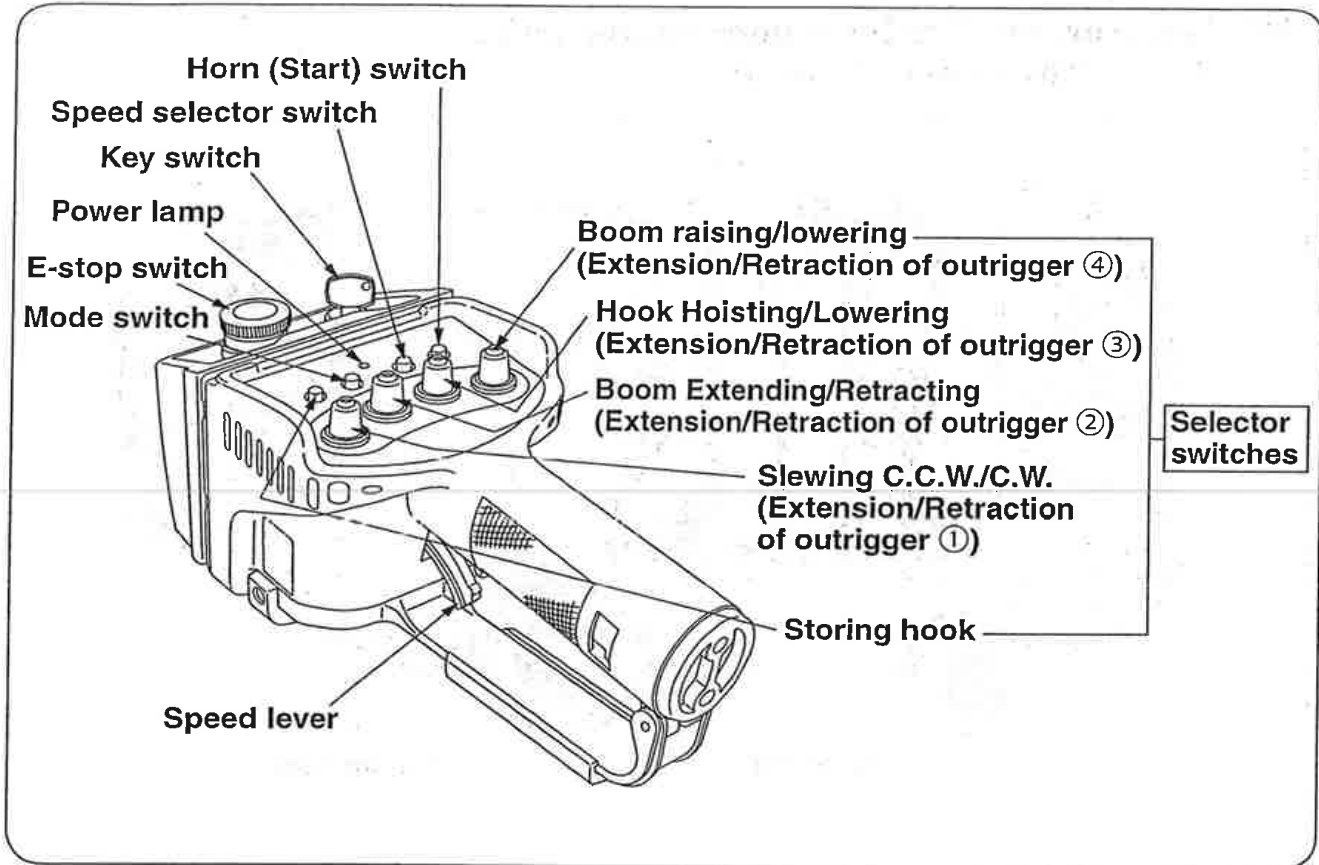

◆3. Designation of each part of receiver

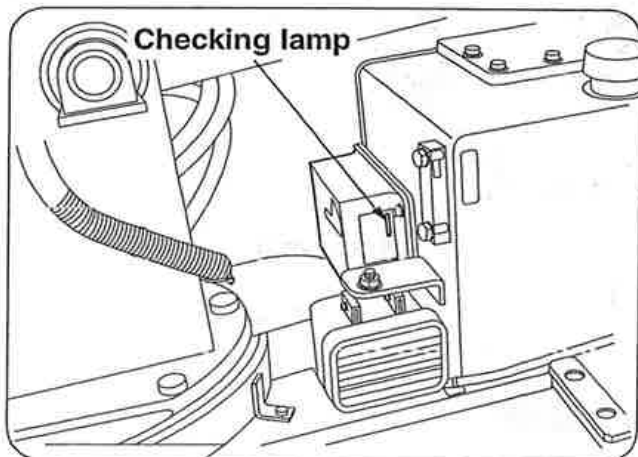

Receiving antenna is built in the receiver.

U-WAVE, RADIO REMOTE CONTROL DEVICE

◆4. Designation of each part of control box

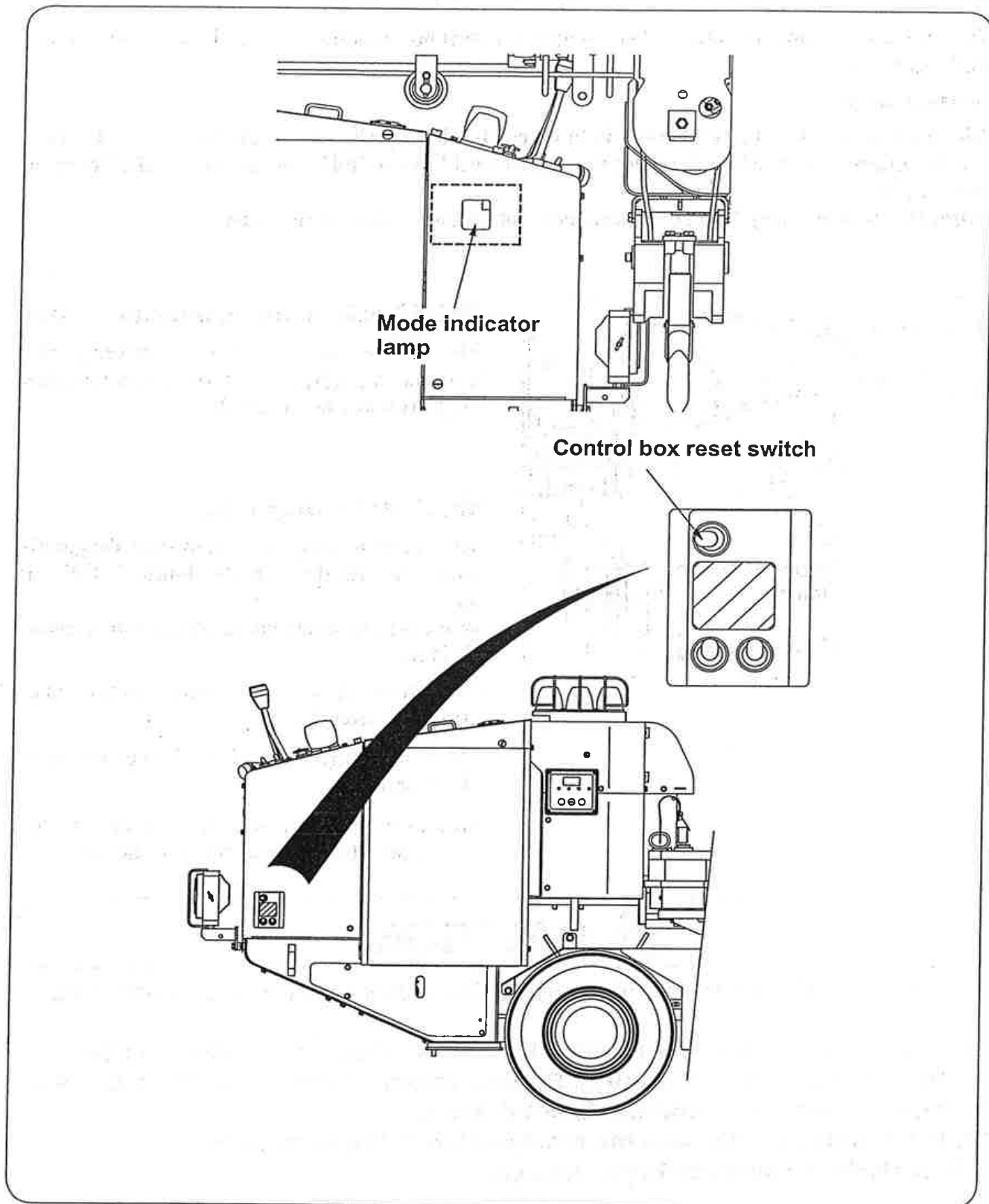

U-WAVE, RADIO REMOTE CONTROL DEVICE

4 Inspection before crane operation

Before starting crane operation, check that the control box functions correctly according to procedures below.

● Remarks

Since power to the "control box" is to be controlled by the motor starter key, it is energized automatically when starting the motor and "mode indicator lamp" in the "control box" lights.

Also, the "power lamp" on the "radio control receiver" blinks in green.

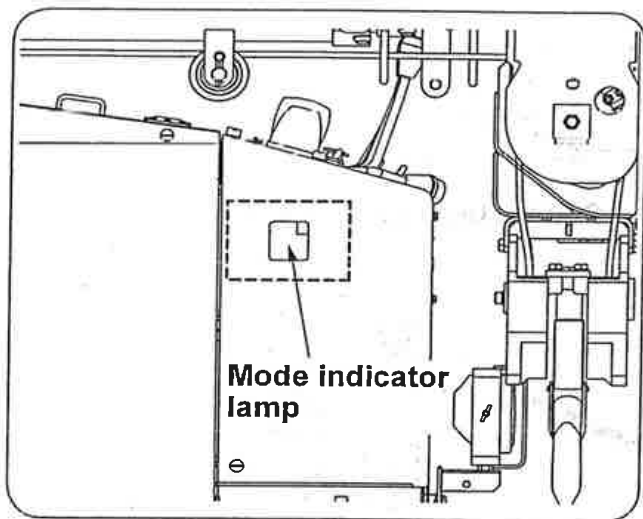

◆ 1. Checking mode indicator lamp

The "mode indicator lamp" makes a full lighting as in [B.B.] for about 2 seconds after the starter key is turned ON.

◆ 2. System diagnosis

The crane is carrying out system diagnosis while the "mode indicator lamp" is fully lit up.

What is to be checked during system diagnosis is if:

- Electronic circuit in the control box is functioning correctly,
- Manual control lever is at its neutral position, and
- Radio control receiver is connected to the crane and the receiver functions normally.



CAUTION

★ Do not make a crane operation while system diagnosis is being carried out.

If the crane is operated during the system diagnosis, voice message, "Beep, Service remote control, Service remote control", sounds and the crane is turned into inoperable conditions.

If this happened, depress the reset switch in the control box.

This starts the system diagnosis again.



U-WAVE, RADIO REMOTE CONTROL DEVICE

If it was found normal after the system diagnosis has been completed, the mode indicator lamp lights either one of following indication and voice message, "Ping-pong, Remote control ready, Remote control ready", is issued.

Mode	Information	Indication priority
00	Current operation mode is on normal radio remote control mode.	4
0F	Current operation mode is traveling mode.	1
04	Current operation mode is on outrigger radio remote control mode.	2
10	Hook hits against weight for over-winding alarm (over-wound condition).	3

- Since priority is assigned for each mode in its information, it is to be indicated in the order of higher priority.

● **Remarks**

If the "mode indicator lamp" indicates [04], current control is on outrigger radio control mode.

No crane operation other than extension/retraction of outriggers is possible.

When operating the crane, turn the "crane/outrigger operation mode selector" switch to "crane".

 **CAUTION**

★ If the "mode indicator lamp" fails to make a full lighting during system diagnosis, or voice message, "Beep, Service remote control, Service remote control", is issued despite the fact that the crane has not been operated, take measures according to the section 13. 8 ◆3. "Trouble inspection" (on page 13-39).

U-WAVE, RADIO REMOTE CONTROL DEVICE

5 How to switch crane operation mode

The crane can be operated either by manual control levers or by the radio remote control transmitter.

Switch crane operation mode to the manual control mode for operating the crane with manual control lever, and to the radio remote control mode for operating the crane through radio remote control transmitter.

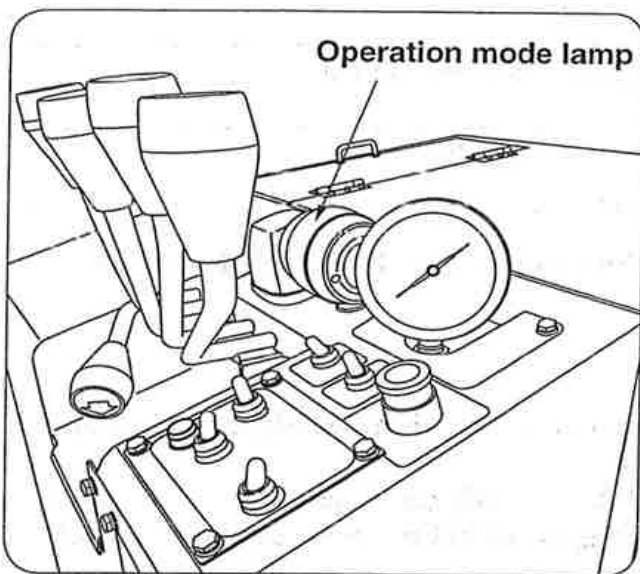

How to switch operation mode

Switching of manual control mode between radio remote control modes is to be made by the radio control selector switch mounted on the cover.

Depression of radio control operation switch when operated on manual operation mode allows to switch it into the radio control operation mode and following voice message is issued:

"Remote control ready, Remote control ready"

The operation mode lamp lights when switched to the radio control operation mode.

Depression of radio control operation switch when operated on the radio remote control mode allows to switch it into the manual operation mode and following voice message is issued:

"Crane mode, Crane mode"

The operation mode lamp goes off when switched to the manual operation mode.

The crane can only be operated via manual control levers when it is on the manual control mode but it cannot be operated through the radio control transmitter.



U-WAVE, RADIO REMOTE CONTROL DEVICE

The crane can only be operated through the radio control transmitter when it is on the radio remote control mode but it cannot be operated via manual control levers (including outriggers).

List of available functions to be operated on each control mode

Crane operation		Operation mode	
		Manual	Radio remote control
Manual lever	Boom Raising/Lowering	○	×
	Hook Hoisting/Lowering	○	×
	Boom Extending/Retracting	○	×
	Slewing C.C.W./C.W.	○	×
	Outrigger Extend/Retract	○	×
Radio remote control transmitter	Boom Raising/Lowering	×	○
	Hook Hoisting/Lowering	×	○
	Boom Extending/Retracting	×	○
	Slewing C.C.W./C.W.	×	○
	Storing hook	×	○
	Mode	×	○
	Speed select	×	○
	Horn	×	○
Emergency stop	×	○	

Operation ○: Possible ×: Impossible

● Remarks

The crane cannot be operated both by manual and by radio remote control without selecting operation mode.

Operation mode of the crane can also be selected by "Radio control operation switch" located on lower side of the control box.

The operation mode is to be memorized even after power to the crane has been turned OFF.

U-WAVE, RADIO REMOTE CONTROL DEVICE

6 *How to operate the crane through radio control operation*

◆ **1. Preparation before operation**

1. Extend the outriggers to their maximum with the manual control lever and level the crane.

- The outriggers are to be controlled on manual operation mode.
If manual mode has not been selected, depress the "radio remote control selector switch" on the switch panel to turn it to be operated on manual mode.

● **Remarks**

If a crane operation (such as boom Raising/Lowering, hook Hoisting/Lowering, boom Extending/Retracting, and slewing C.C.W./C.W.) is carried out while the outriggers are being extended or retracted by manual control lever, the crane will make an automatic stop to avoid dangerous situation.

(The "mode indicator lamp" blinks [□4]. Refer to section "9 Mode indicator lamp" on page 13-43 for detail.)

If this has taken place, stop both operation of the crane and of the outriggers once and try carrying out extension and retraction of outriggers again.

2. Check that the "E-stop switch" on the transmitter has been reset to turn ON the "key switch".

If the "E-stop switch" has not been reset, turn the switch clockwise or pull the switch to reset it.

- Emergency stop function is to be actuated if the "E-stop switch" is pushed in, and emergency stop resets when it is not being depressed.

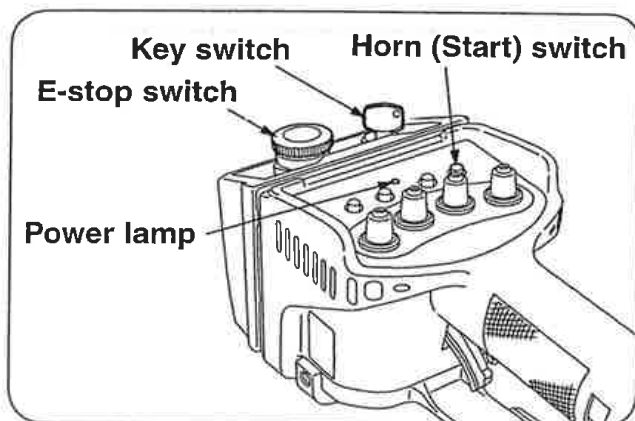

U-WAVE, RADIO REMOTE CONTROL DEVICE

3. Depression of the "horn (start) switch" on the transmitter energizes the transmitter and "power lamp" lights (in red, in orange, or in green).

- Power to the transmitter is to be turned OFF by pushing in the "E-stop switch", or by turning OFF the "key switch, or if time has passed for more than 5 minutes when no crane operation has been carried out.
- If the "power lamp" blinks or fails to be lit, replace batteries of transmitter according to the section 13. "◆3. How to replace batteries" illustrated on page 13-36.

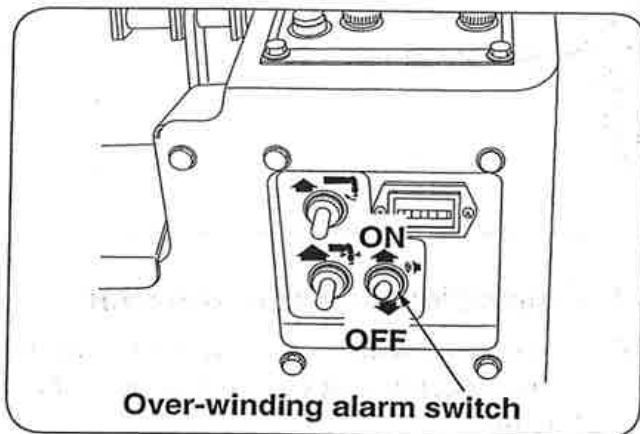

4. Check that the voice switch has been turned ON.
If not, turn it ON.

● Remarks

Voice message will not be issued when the voice switch has been turned OFF.

5. Depress the "radio remote control selector switch" on the switch panel to turn it to be operated on radio remote control mode.

The mode indicator lamp indicates [00] and the following voice message is issued:

"Remote control ready, Remote control ready"

- When the operation mode is switched to "radio remote control mode." with power to transmitter turned OFF, the mode indicator lamp indicates [90].

Turning ON the power to the transmitter allows the mode indicator lamp to indicate [00].

U-WAVE, RADIO REMOTE CONTROL DEVICE

◆2. How to operate

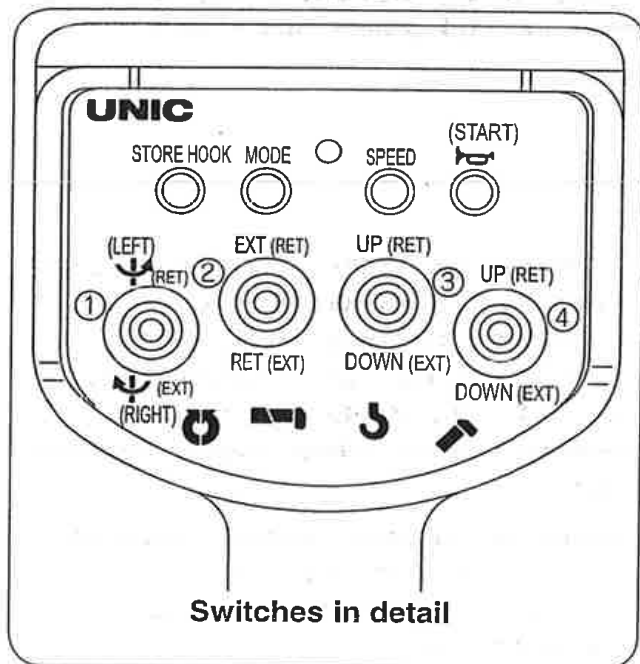
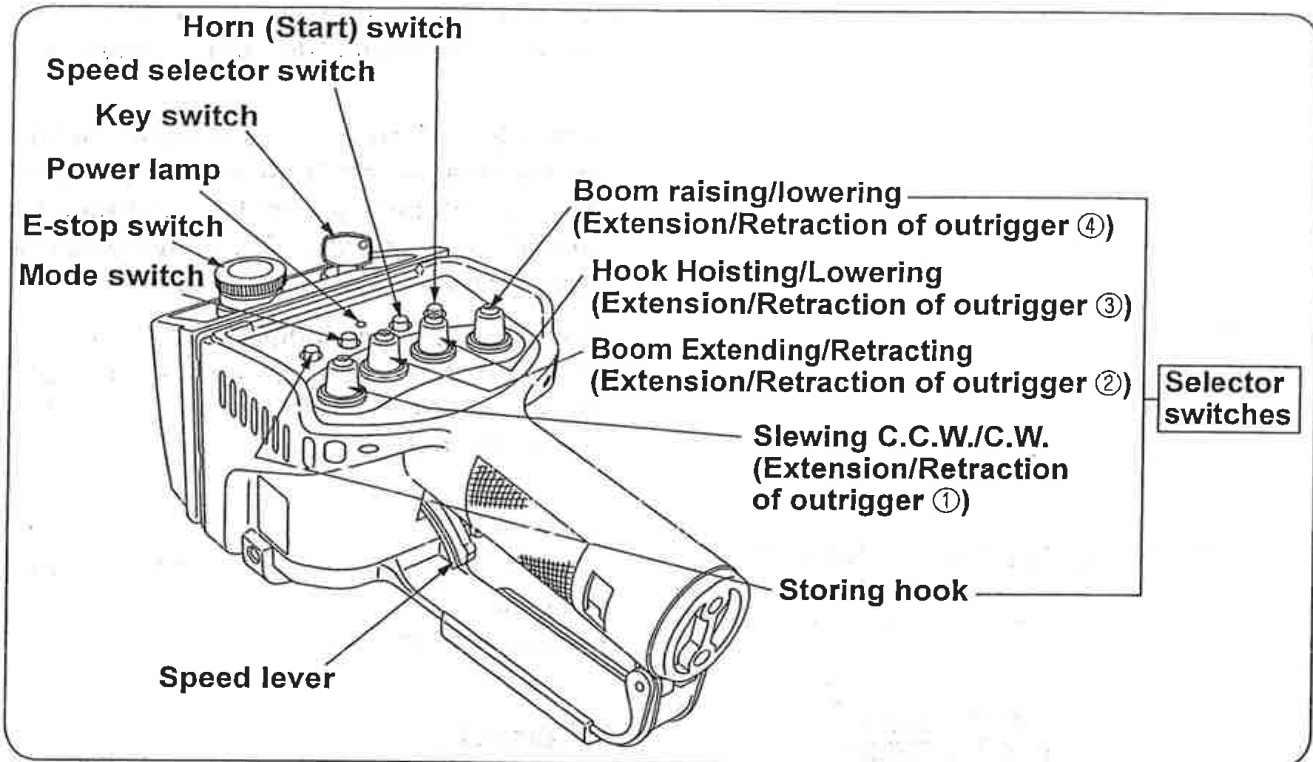

1. Operation of crane function

(1) Throw a corresponding "selector switch" to the direction allowing the desired crane function.

(2) Pull the "speed lever" slowly with the "selector switch" remained as it has been thrown.

If only one of the selector switches is to be operated, the crane starts to move slowly with the motor rotated at a low speed when pulling the "speed lever" slowly.

When the speed lever is pulled further, the motor speed increases to allow the operation speed of crane to be faster.

• If the "speed lever" is pulled with more than two "selector switches" thrown, the motor speed becomes faster than that in case of only one of selector switches is being pulled. (However, maximum motor speed will not change. Refer to section 6 "Motor speed control function" (on page 13-24) for detail.

U-WAVE, RADIO REMOTE CONTROL DEVICE

! WARNING

★ When operating the crane with the radio remote control transmitter, be sure not to touch any of manual levers as manual levers shift simultaneously.

(3) When stopping the crane operation, return the "speed lever" slowly, and then return the "selector switch"

(4) Depression of the "horn switch" activates the horn.
Use it when calling attention to those who stand around the vehicle.

● **Remarks**

- Switches mounted on the remote controller are ON/OFF type which can be actuated with a light touch. Do not apply strong force as it may cause damage to the switches.
- When the same radio wave (of specified small power radiation type radio system) is being used near by working site, response time of the crane it takes from the time when the radio remote control device has been operated may become longer to some extent which is not a fault.
- When operating with the remote controller, working speed may become a bit slower than that of manual operation.

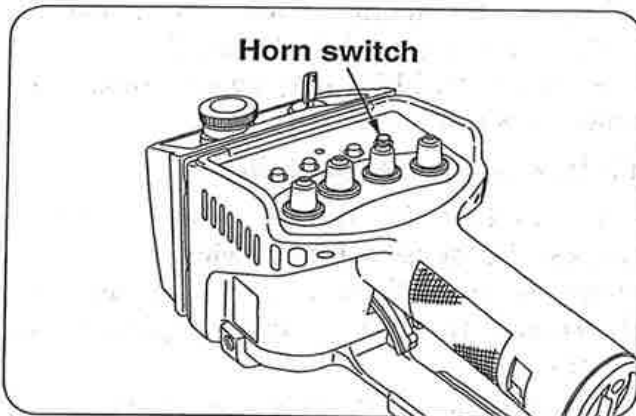

U-WAVE, RADIO REMOTE CONTROL DEVICE

2. How to confirm and change speed mode

When operating the crane with the motor running at a medium speed, or at a lower speed such as in case of working at night, the speed mode can be changed.

(1) How to confirm speed mode

Check the "power lamp" for lighting color, if it is lit in;

- ① Red : High speed mode
- ② Orange : Medium speed mode
- ③ Green : Low speed mode

If the "power lamp" is not lit, turn ON the power to transmitter to light the "power lamp".

• Orange illumination is realized by lighting both red and green LED elements. Red and green LEDs may be seen separately where it is in a lot of sunshine.

(2) How to change speed mode

Confirm that the "power lamp" is lit to depress the "speed selector switch".

Every time the "speed selector switch" is depressed, the "power lamp" lights in the order of



changing speed mode accordingly.

Depression of the "speed selector switch" with the "power lamp" lit in red allows the lamp to light in orange changing it into on medium speed mode.

Depression of the "speed selector switch" with the "power lamp" lit in orange allows the lamp to light in green changing it into on low speed mode.

Depression of the "speed selector switch" with the "power lamp" lit in green allows the lamp to light in red changing it into on high speed mode.

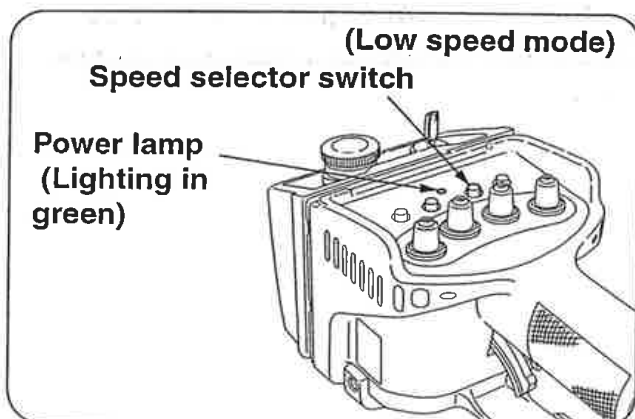
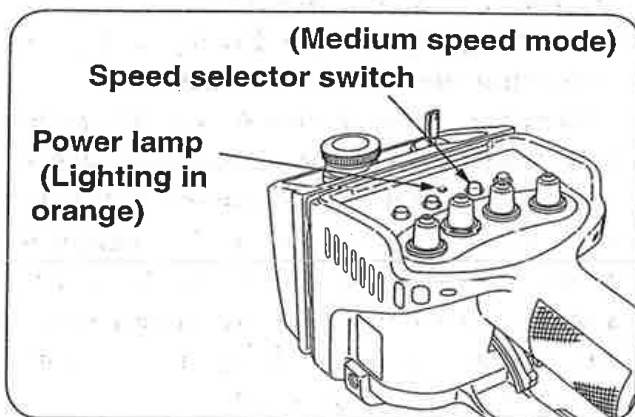
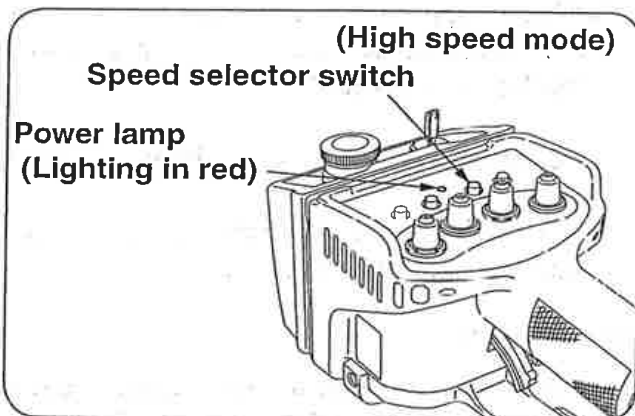



U-WAVE, RADIO REMOTE CONTROL DEVICE

● **Remarks**

Setting of speed mode is to be memorized even when power to transmitter has been turned OFF.

Note that a slight speed difference between slewing C.C.W./C.W. may be found when slewing it on the low speed mode which is not a fault.

(3) Speed mode and manual lever control

Manual lever control is also applied to the speed mode.

High speed mode..... Motor will run at maximum speed.

Medium speed mode Motor will run at medium speed range.

Low speed mode Motor will run at minimum speed.

● **Remarks**

Speed mode can only be changed through radio control transmitter.

Speed mode switches to high speed mode when power to the crane is turned OFF (starter switch is turned OFF).

Since setting of speed mode is memorized even when power to radio control transmitter has been turned OFF, speed mode is switched to the mode as the radio control transmitter has memorized previously when the crane is operated through radio control transmitter after power to the crane is turned ON again.

U-WAVE, RADIO REMOTE CONTROL DEVICE

3. Interlocking balance control function

When interlocking operation (operation of speed lever with more than 2 of "selector switches" thrown) is carried out through the radio control transmitter, the system equips the function controlling movement of each control lever for each combination of the "selector switches".

Therefore, when the speed lever is pulled to its extreme, movement of each control lever varies in accordance with combination of "selector switches".

In some cases, the control lever may not be shifted to its full extent despite the fact that the speed lever on the radio control transmitter has been fully pulled which is not a fault.

● Remarks On interlocking balance retaining function:

The crane equips interlocking retaining function which prevent its operating speed from making an abrupt increase when interlocking operation is switched to independent operation,

When operation is switched from interlocking to independent (change from operation of speed lever with more than 2 of "selector switches" thrown to operation of speed lever with one of "selector switches" thrown), control speed may become slower as oppose to that of the independent operation, which is not a fault.

In order to correct this, release all the "selector switches" once and go back to independent operation again.

For immediate returning to normal speed of independent operation when it is switched from interlocking to independent, validity of interlocking balance retaining function can be switched through the transmitter.

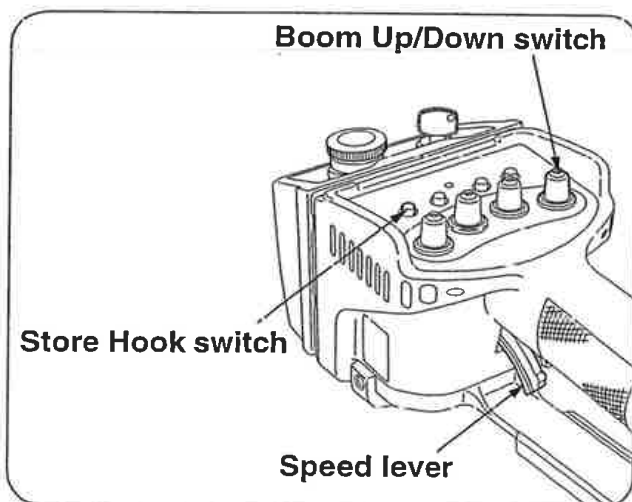

In order for the interlocking balance retaining function to be invalid, depress the "store hook" switch with the "boom Up/Down" switch turned to "Down".

Voice message, "Change control mode, Change control mode", sounds and the interlocking balance retaining function changes to be invalid.

(The voice message does not sound when the function remains as it was.)

Switching condition of the interlocking balance retaining function can be confirmed as the mode indicator is to be lit as in [$\square F$] (meaning "invalid") while the switch is being controlled.



U-WAVE, RADIO REMOTE CONTROL DEVICE

In order for the interlocking balance retaining function to be valid, depress the "store hook" switch with the "boom Up/Down" switch turned to "Up".

Voice message, "Change control mode, Change control mode", sounds and the interlocking balance retaining function changes to be valid.

(The voice message does not sound when the function remains as it was.)

Switching condition of the interlocking balance retaining function can be confirmed as the mode indicator is to be lit as in [□□] (meaning "valid") while the switch is being controlled.

CAUTION

★ Be careful that the operation speed returns to that of independent operation immediately when it is switched from interlocking to independent with the interlocking balance retaining function switched to be invalid.

● Remarks

If the "boom Up/Down" switch is controlled before depression of the "store hook" switch, voice message, "Ping-pong, Secure lifting hook, Secure lifting hook", may sounds which is not a fault.

The interlocking balance retaining function switches regardless of sounding voice message.

The interlocking balance retaining function is to be memorized even after power to the crane has been turned OFF.

4. Temporary changing function of interlocking balance (Click operation)

When interlocking operation with 2 "selector switches" thrown (2-interlocking operation) is carried out with the radio control transmitter, each speed balance can be changed temporarily.

Click a "selector switch" for which faster speed is needed during 2-interlocking operation.

Operating speed related to the "clicked" switch becomes faster than that of other operation.

The more number of times a switch has been clicked, the faster the operation related to the clicked switch becomes as opposed to against that of other operation relatively.

Turning OFF both "selector switches" on 2-interlocking operation releases the function to allow them to return to previous conditions.

U-WAVE, RADIO REMOTE CONTROL DEVICE

• Example of operation

Interlocking operation of both "Boom extending" and "Hook Lowering".

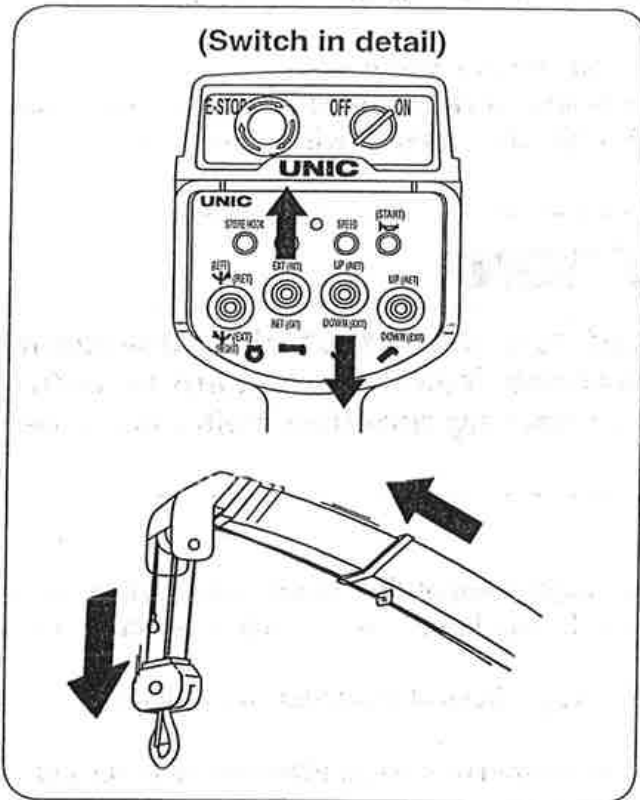

Pull the speed lever with the "hook Up/Down switch" thrown to "Down" and the "Boom Ext/Ret switch" put to "Ext".

The hook lowers and the boom starts to extend.

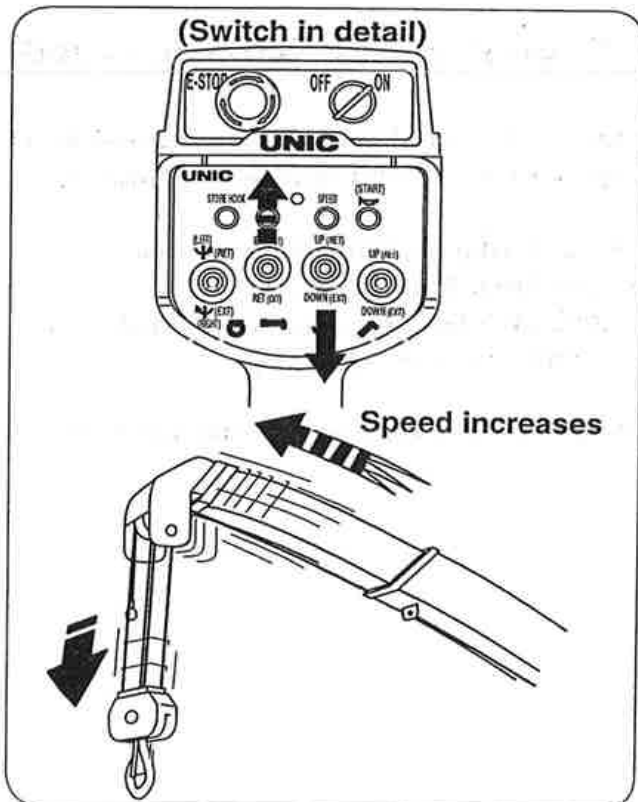

• **To increase extending speed of boom**
Click (operate it quickly in order of ON→OFF→ON) the "Boom Ext/Ret switch" to "Ext" side.

This allows extending speed of boom to become faster than that of hook down.

The more number of times the switch has been clicked toward "Ext", the faster the boom extension becomes as oppose to that of hook down.

U-WAVE, RADIO REMOTE CONTROL DEVICE

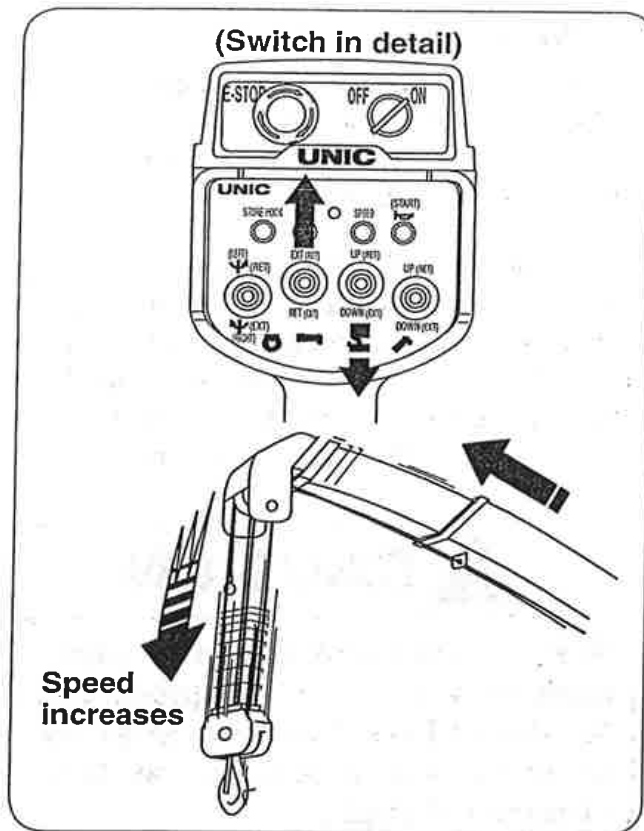

- To increase winding Down speed of hook

Click the "hook Up/Down switch" to "Down" side.

This allows the speed of hook down to become faster than that of boom extension.

The more number of times the switch has been clicked for "Down", the faster the speed of winding down hook becomes as opposed to that of boom extension.

● Remarks

- Repeated clicks allow the other operation not to function in the end.
If this happened, release all the "selector switches" once, or click the "selector switch" for which operation is inactivated.
- When one of "selector switches" is released during the clicking operation, speed of crane under operation may become faster.
- The clicking function is possible only when in 2-interlocking operation.
It will not be applied to operation such as of 3-interlocking and 4-interlocking.

U-WAVE, RADIO REMOTE CONTROL DEVICE

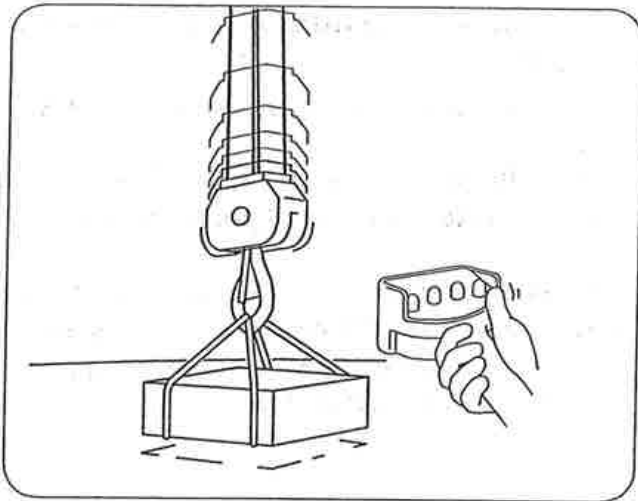

5. Shock-less function

The system equips a "shock-less" function allowing the crane to stop gently even when the crane has been made an abrupt stop by radio control transmitter.

Since the crane will not make an abrupt stop against a sharp operation, it eases shock to the crane and/or to the mounted vehicle, and it is also effective to prevent the wire rope from jumping up and a lifted cargo from swinging when the hook has stopped winding-up.



CAUTION

★ Pay attention that the crane makes a slight movement due to shock-less function after the radio control operation has been stopped abruptly.

● Remarks

When making the crane a sudden stop:

If the crane has to be made a sudden stop, actuate the "selector switch" controlling opposite function while the shock-less is functioning.

(Do not pull the speed lever in this case.)

Otherwise, the shock-less function is released to allow the crane to make a sudden stop.

When canceling the shock-less function:

If the shock-less function is unnecessary, it can be activated/inactivated by the radio control transmitter.



U-WAVE, RADIO REMOTE CONTROL DEVICE

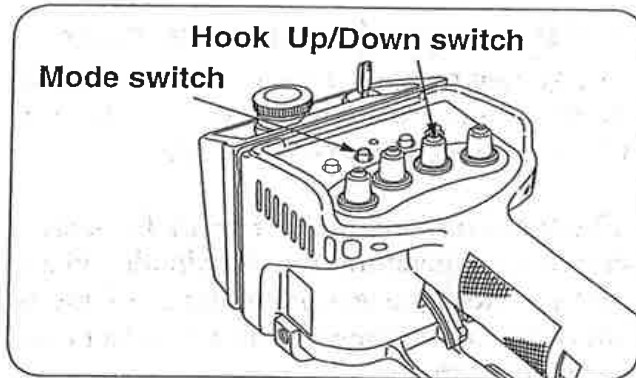

In order to inactivate the shock-less function, throw the "hook Up/Down" switch to "Down" with the "mode switch" depressed. The shock-less will not be functioning.

In order to activate the shock-less function, throw the "hook Up/Down" switch to "Up" with the "mode switch" depressed. The shock-less starts functioning.

When the shock-less function is active and the "mode indicator lamp" shows any of [00], [01], [04], [06] and [07], switching it to be inactive allows the figure indicated on the left to change to [-].

Switching the shock-less function to be active allows the mark [-] indicated on the left to change to [0].

Mode display	
When shock-less function active:	When shock-less function inactive:
00	-0
01	-1
04	-4
06	-6
07	-7

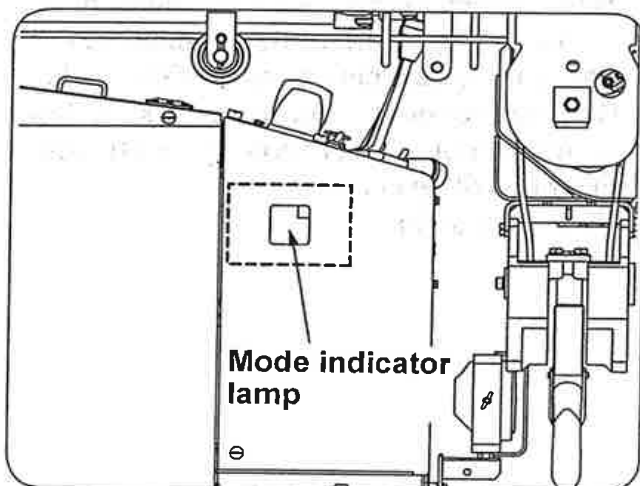

CAUTION

★ Be sure to check if the mode indicator changes accordingly after the shock-less function has been switched.

● Remarks

When the mode indicator shows [10] (overwound condition), no change happens even after the shock-less function has been switched.

When checking condition of the shock-less function, remove the over-wound condition by operation of lowering hook or retracting boom.

Setting of shock-less function is to be memorized after power to the crane has been turned OFF.

U-WAVE, RADIO REMOTE CONTROL DEVICE

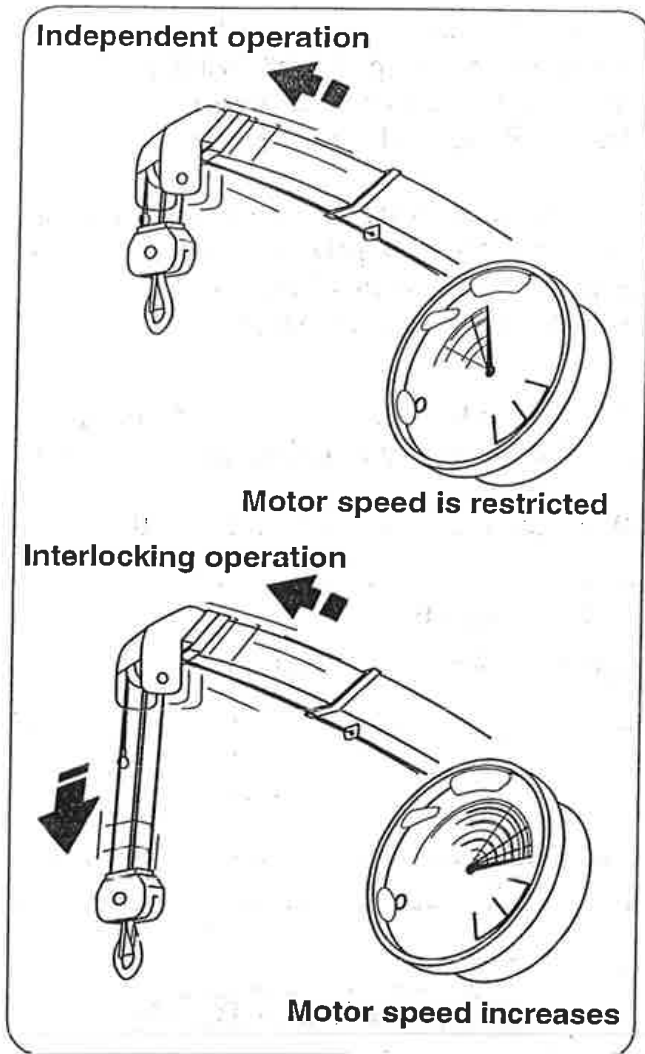

6. Motor speed control function

The system equips a function controlling the motor running at a suitable speed according to operating condition of the crane.

The function helps save energy because it can ease temperature rise of hydraulic oil and restrict the unnecessary increase of motor speed by controlling the motor to run at an appropriate speed.

- On independent crane operation, it allows the motor speed not to be increased unnecessarily while the crane is operating functions such as lowering boom, retracting boom, slewing C.C.W./C.W., and retracting outriggers.
- The motor speed increases when the crane operation has been switched from independent to interlocking. (But no change in maximum motor speed.)
- The motor runs at a medium speed while the outriggers are being extended and retracted.
- When swinging the crane on independent operation by controlling manual lever, swinging speed may become faster when the independent operation is switched to interlocking operation by controlling other one of levers.
This is not a fault.

U-WAVE, RADIO REMOTE CONTROL DEVICE

◆ 3. How to store hook

! WARNING



★ Since releasing the hook from its stored position allows it to swing, it may cause an accident if a person stands under or in front of the hook.

In addition, excessive pulling of the “speed lever” increases the hook to swing that is dangerous so that do not pull the lever extremely.

★ It is strictly prohibited to operate the crane with the “storing hook” as this is very dangerous.

★ Retract the boom fully and lower it to its extreme to store it.

★ Do not operate the “storing hook” with any one of control levers at the same time.

This may cause an incorrect action and/or a breakdown of the crane.

★ Pay attention that the manual control lever for “hook Up/Down” moves “Up” side when retracting the hook.

U-WAVE, RADIO REMOTE CONTROL DEVICE

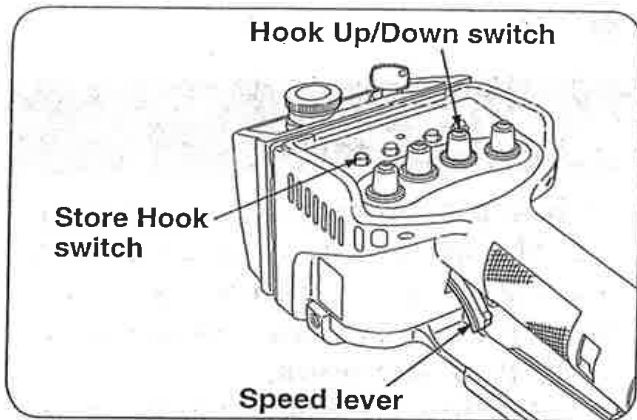

(1) Wind up the hook with the "hook Up/ Down" of selector switches.

The hook stops being wound-up automatically when it hits against the weight for overwinding alarm.

- When it stops being wound-up, following voice message, "Beep, Stop winch up, Stop winch up, Beep, Beep" is issued.

The last part of voice message, "Beep, Beep", stops sounding when the operation concerned has been stopped.

(2) Depress the "store hook switch" after the hook is at a standstill.

- Following voice message, "Ping-pong, Secure lifting hook, Secure lifting hook" is issued.

(3) When pulling the "speed lever" with the "store hook switch" depressed, the hook starts being wound up slowly.

The "mode indicator lamp" indicates [] while the hook is being stored.

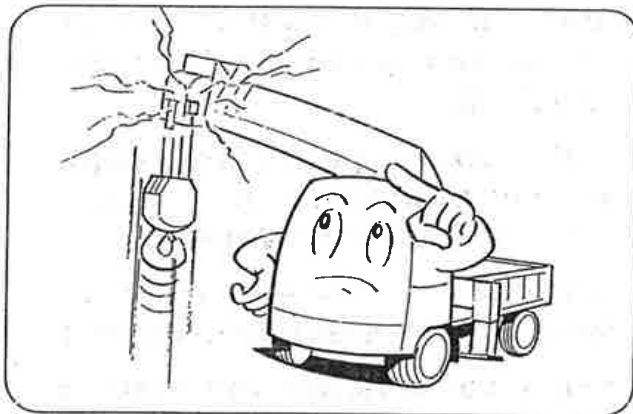

CAUTION

★ Storing the hook while it is swinging may cause damage to the boom, to the hook itself, and to the wire rope.

U-WAVE, RADIO REMOTE CONTROL DEVICE

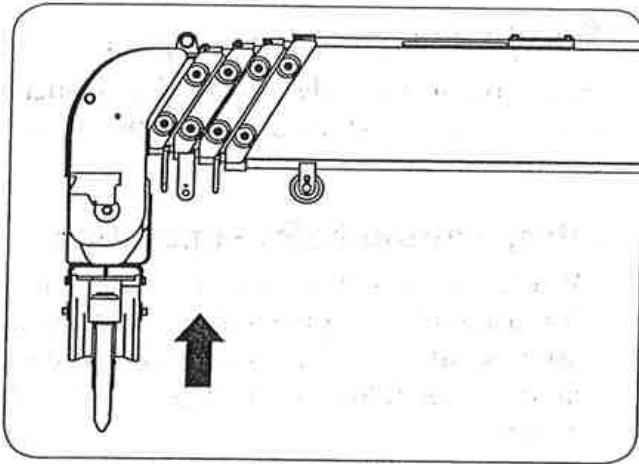

- (4) The hook hits against the guide on the boom top to be stored in position
Storing hook operation stops when the "speed lever" is returned and then the "store hook switch" is returned.

● **Remarks**

The motor is still running at a low speed (idling) while the hook is being stored.

CAUTION

★ If the hook hits against the guide on the boom top obliquely or it is off the guide halfway, wind-down the hook to try storing operation again.

U-WAVE, RADIO REMOTE CONTROL DEVICE

◆ 4. How to operate outriggers

Crane operation mode and outrigger operation mode can also be switched from radio control transmitter.

1. Preparation before operation

When the selector switch is thrown to "Outrigger" the outrigger mode indicator lamp located on the cover lights and the mode is switched to outrigger operation mode.

Indication of "mode indicator lamp" changes to [04] and [05], and voice message, "Change control mode", is issued.

● Remarks

Turning OFF switch on the buzzer to stop the alarm sound.

If alarm sound of buzzer is to be avoided such as in working at night, turn it OFF to stop the buzzer.

Turn it ON when in normal crane operation.

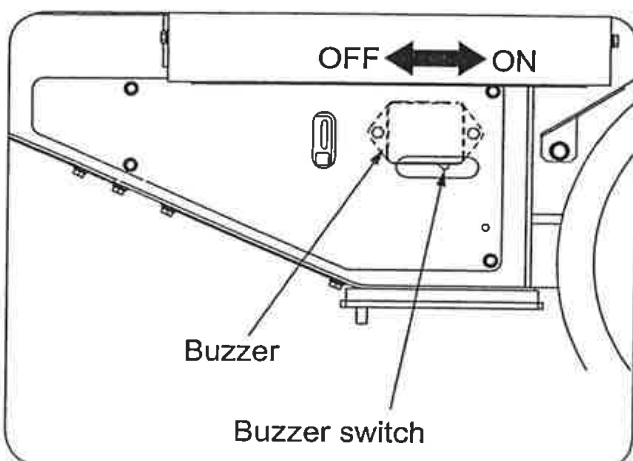
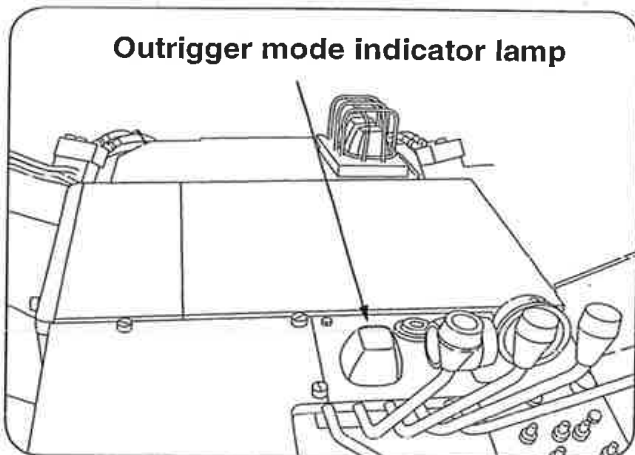
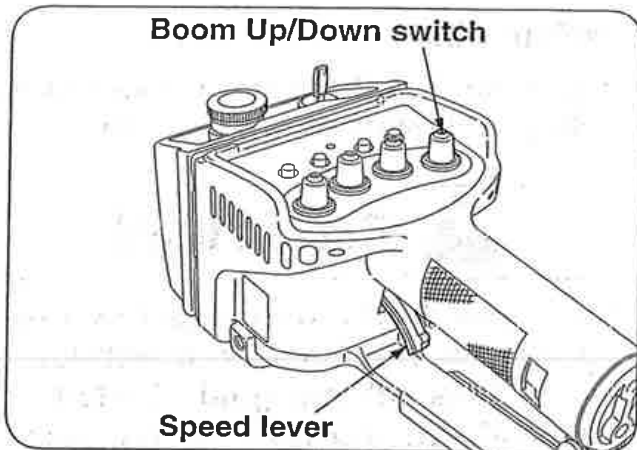

U-WAVE, RADIO REMOTE CONTROL DEVICE

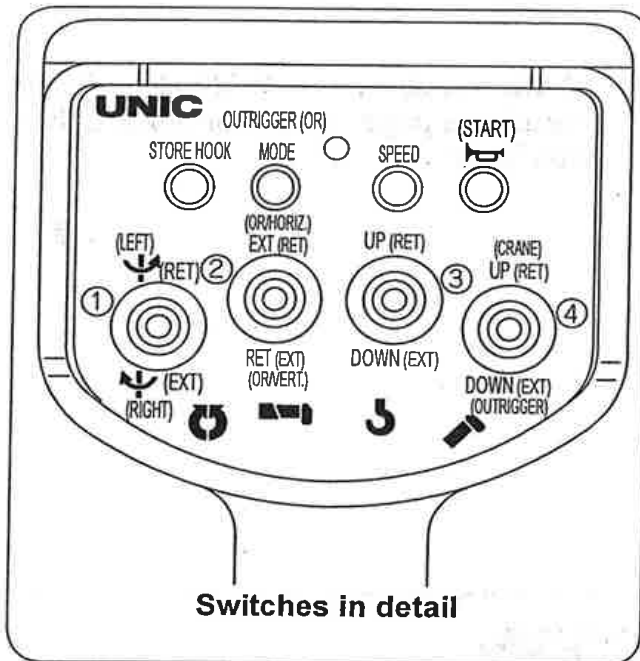
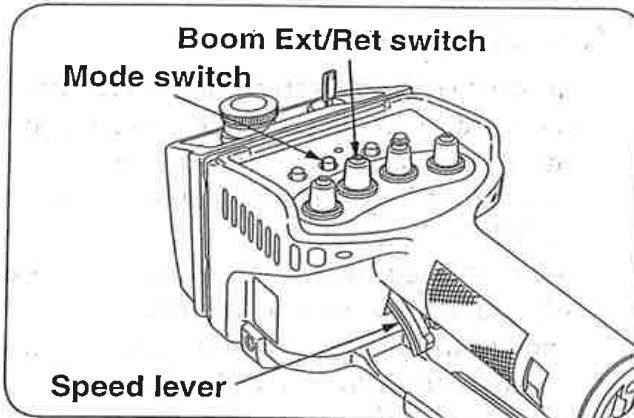

2. Operation

Throw the "selector switch" corresponding to the outrigger number requiring control to the desired operation side.

Then pull the "speed lever" slowly while keeping the "selector switch" thrown to the desired operation.

As the "speed lever" is pulled slowly, the vertical cylinder starts to be operated gradually with the motor running at a low speed, and pulling it further allows operating speed of the vertical cylinder becomes faster as the motor speed is increased.

To extend

Turn the switch to "Ext" to pull the "speed lever".

To retract

Turn the switch to "Ret" to pull the "speed lever".

To stop

Return the "selector switch" after the "speed lever" has been returned slowly.

● Remarks

When the "crane/outrigger operation mode selector switch" is turned to "outrigger" (outrigger mode indicator lamp is being lit), normal crane operation of "boom Up/Down", "hook Up/Down", "telescoping boom", "slewing C.C.W./C.W.", and "storing hook" to be impossible both in radio control transmitter and in manual control lever.

When the selector switch is thrown to "crane" voice message, "Change control mode", is issued and the mode is switched to crane operation mode when the yellow lamp located on the cover goes off.

CAUTION

★ If it has been selected to the mode (operation) to which is going to be selected, voice message will not be issued.

U-WAVE, RADIO REMOTE CONTROL DEVICE

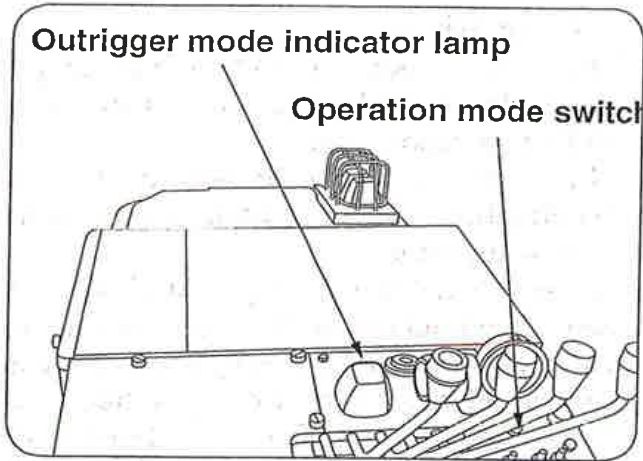

3. Closing operation

When extending/retracting operation of outrigger through the radio control transmitter has been over, be sure to turn the "crane/outrigger operation mode selector switch" to "crane".

The outrigger mode indicator lamp goes off and the buzzer stop sounding.

Indication of the "mode indicator lamp" changes to either one of [00], [01], [06], or [07], and voice message, "Change control mode", is issued.

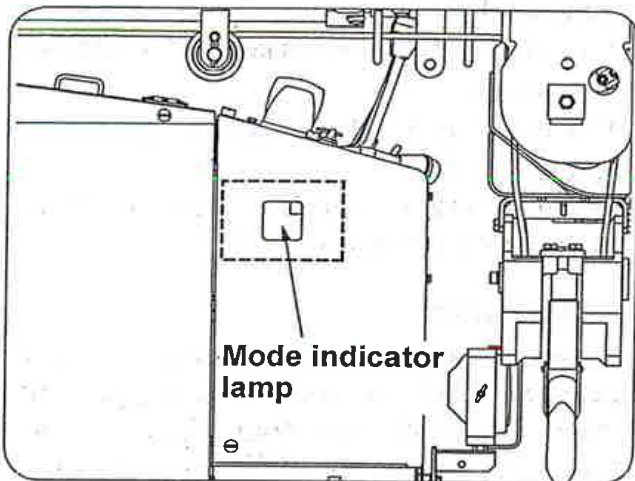

(Refer to section 13. 9 "Mode indicator lamp" (on page 13-43) for mode indication in detail.

CAUTION

★ Take special care that your foot will not be stamped by outrigger while extending outriggers.

★ Be sure to secure the hook in place while outriggers are being operated.

*U-WAVE, RADIO REMOTE CONTROL DEVICE* **CAUTION**

★ When the motor is to be stopped for a long period of time, be sure to turn OFF the starter key on the side of crane.

★ The radio control system carries out system diagnosis automatically every time when power is turned ON.

Do not operate the crane while the system diagnosis is being carried out.

(Do not touch any one of switches and levers during this period.)

If the crane is operated during system diagnosis, voice message, "Beep, Service remote control, Service remote control", sounds and the crane is turned into inoperable conditions.

If this happened, depress the reset switch in the control box to carry out system diagnosis again.

★ If the voice message, "Beep, Service remote control, Service remote control", is issued when turning ON the power despite the fact that the crane has not been operated, ask a UNIC authorized service shop for repair as failure in the radio control system is suspected.

U-WAVE, RADIO REMOTE CONTROL DEVICE

◆5. How to operate when motor speed becomes unstable due to low temperature

When in winter season or when temperature is too low, the motor speed may become unstable as viscosity of hydraulic oil increases.

In this case, switch the system to "low temperature operation mode" to allow the motor speed to be stable.

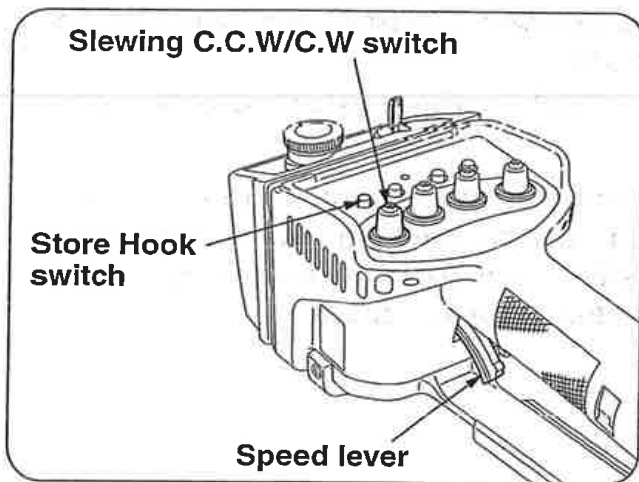

1. Switching to low temperature operation mode

Depress the "store hook switch" with the "slewing C.C.W./C.W. switch" turned to "C.C.W.".

Indication of the "mode indicator lamp" changes to [05]; and voice message, "Ping-pong, Change control mode, Change control mode", is issued.

(Indication will not change if the "mode indicator lamp" is showing [04], [05], or [10].)

● Remarks

When switching it to low temperature operation mode, operation of the "store hook switch" before the "swing C.C.W./C.W. selector switch" has been actuated may allow voice message, "Ping-pong, Secure lifting hook, Secure lifting hook", to be issued.



U-WAVE, RADIO REMOTE CONTROL DEVICE

2. Resetting low temperature operation mode

Depress the "store hook switch" with the "slewing C.C.W./C.W. switch" turned to "C.W.". Indication of "mode indicator lamp" changes to [00] and voice message "Ping-pong, Change control mode, Change control mode", is issued. (Indication will not change if the "mode indicator" is showing [04], [05], or [10].)

In addition, the low temperature operation mode is to be reset automatically, even when operation illustrated above has not been carried out, after approx. 10 minutes from the time when it has been switched to the "low temperature operation mode".

The voice message "Ping-pong, Change control mode, Change control mode", is issued at this time.

● **Remarks**

Response of the crane functions becomes slower when operated on low temperature operation mode.

In normal case, operate the crane after warming-up for a while to raise temperature of hydraulic oil.

Under extreme low temperature, crane operation may still be unstable even after the system has been switched to the "low temperature operation mode".

In this case take measures such as by carrying out warm-up operation to raise temperature of hydraulic oil or by using hydraulic oil suitable for extreme low temperature.

 **CAUTION**

★ If viscosity of hydraulic oil is too high at a low temperature, excessive load will be imposed on hydraulic pumps which may cause damage to them.

In order to avoid this, be sure to carry out warming-up to raise temperature of hydraulic oil to an appropriate temperature to operate the crane.

◆ **7. Closing crane operation**

After completion of the crane work, turn OFF the starter switch to shut off power to the crane after the boom, the hook, and the outriggers have been stored in their respective positions.

U-WAVE, RADIO REMOTE CONTROL DEVICE

7 *How to replace batteries of transmitter*

◆ 1. When to replace batteries

CAUTION

★ When the power lamp of transmitter starts blinking, replace the batteries as early as possible. Leaving them as they were may cause the liquid in the batteries to leak.

★ In case where leakage of battery liquid is found, wipe it off the battery holder and the battery case thoroughly to put new batteries in it.

• Check how the "power lamp" lights with the "speed selector switch" on the transmitter depressed.

- ① Continuous lighting: Radio control transmitter can be used.
- ② Blinking in low frequency (a flash every second): It allows the radio control transmitter to be used for about 1 hour after the blinking has started.
Replace the batteries as early as possible as they are close to running out.
- ③ Blinking in high frequency (a flash every 0.1 second): The radio control transmitter can not be used further as the batteries have been running out.
- ④ No lighting: The radio control transmitter can not be used as the batteries have completely run out.

• If the "power lamp" blinks slow as in the state of ② above, following voice message, "Ping-pong, Low transmitter battery, Low transmitter battery", is issued.

The trouble lamp on the receiver blinks in red, and the "mode indicator lamp" shows [99] in blinking.

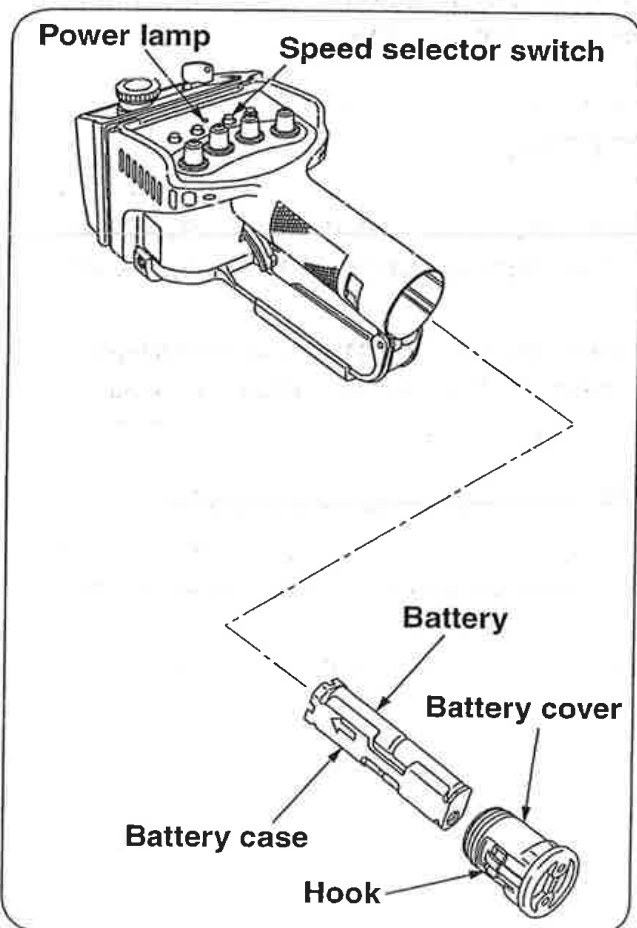



U-WAVE, RADIO REMOTE CONTROL DEVICE

◆ 2. Battery to be employed

a size AAA battery: 4 pieces

Use alkaline-type battery.

(Manganese-type battery has a short service life.)

● Remarks

About the use of rechargeable batteries

Although UNIC recommends the use of alkaline type battery in the radio control transmitter, other rechargeable batteries such as nickel-hydrogen type and nickel-cadmium type may also be used.

Pay attention to the following when a rechargeable battery is used:

- Message suggesting replacement of battery may not be issued.

Be sure to prepare alkaline-type batteries when operating the crane through radio remote control device because rechargeable batteries tend to become inoperable suddenly.

- In some cases, service life of rechargeable battery may become shorter than that of alkaline battery in accordance with the capacity.
- There is a disadvantage such as memory effect comparing with alkaline-type battery.



CAUTION

★ Do not mix up batteries of old and new, of different manufacturers, or of different types.

U-WAVE, RADIO REMOTE CONTROL DEVICE

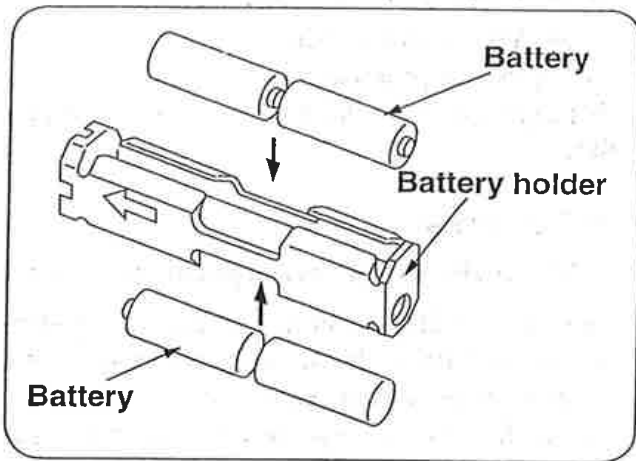

◆ 3. How to replace batteries

- (1) Turn OFF power to the crane (Turn OFF the starter switch.).
- (2) Pull out the battery cover with the hook on the cover pushed in.
- (3) Replace old batteries in the battery holder with new ones.

CAUTION

- ★ Pay attention to polarity of batteries.
(Put them as indicated on the battery holder)
- ★ Do not connect between terminals of (+) and (-) directly with a metal piece.

- (4) Insert the battery holder into the transmitter grip to tighten up the battery cover securely.

CAUTION

- ★ Take care that a drop of water will not enter inside of the grip.

- (5) Depress the "speed selector switch" to check that the "power lamp" lights.

● Remarks

Unless to the power to crane is turned OFF once when replacing batteries, blinking indication of [99] on the mode indicator lamp will not goes off even after batteries have been replaced.



U-WAVE, RADIO REMOTE CONTROL DEVICE

8 *Daily checks, trouble inspection*

◆ **1. Daily checks**

For cranes with radio remote control device, you are requested to inspect your crane for following items as well as carry out daily checks on your crane (read operator's manual of UNIC crane concerned for detail).

Check that;

1. Each enclosure of transmitter, receiver, and control box has not been damaged.
If the enclosure has been damaged, repair it immediately because moisture and/or dust entered through the break may cause a failure to electronic parts inside and cause incorrect operation of the crane concerned.
2. The stay on the transmitter has not been broken or deformed.
The transmitting antenna is built in the stay.
If break or remarkable deformation is found in the stay, replace or repair it as soon as possible because it may cause radio interference.
3. Switches and control levers on the radio control transmitter make a smooth operation.
Using the remote control transmitter with dust, dirt, and mud being stuck on may lead to failure especially in operation of switches and/or control levers.
Wipe them off with a piece of cloth after use.
If any of the selector switches fails to function correctly due to contamination, ask a UNIC authorized service shop for cleaning.

 **CAUTION**

★ **Never try disassembly or alteration of the transmitter, the receiver, and the control box.**

★ **Electric system is very sensitive to moisture.**

Do not wash the transmitter, the receiver, and the control box with water directly.

U-WAVE, RADIO REMOTE CONTROL DEVICE

◆2. Check lamps (Radio control receiver)

Check lamps are mounted on the radio receiver, and they light as follows when it is in normal operating condition:

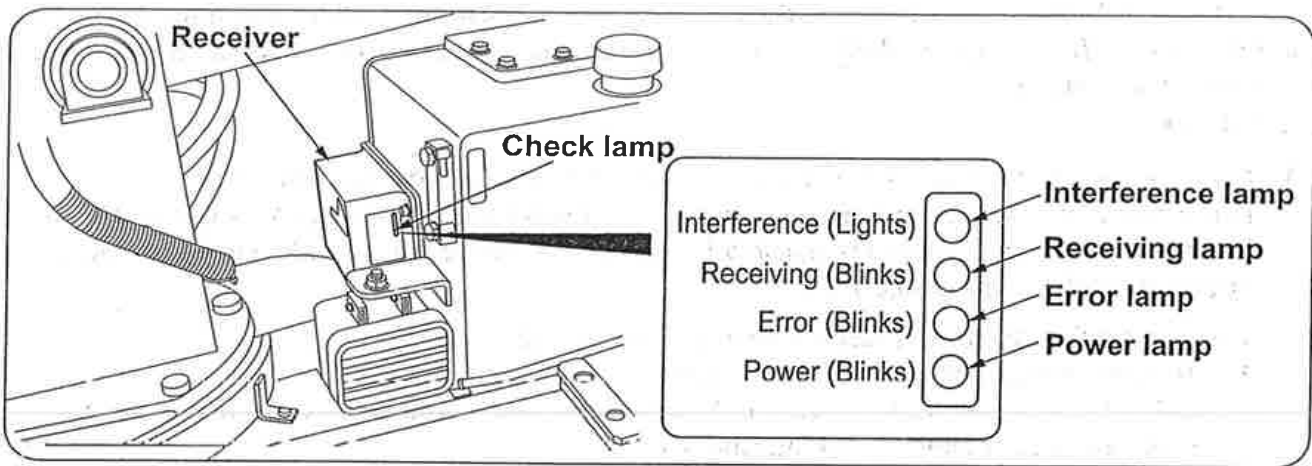

- **Power lamp**

When energizing the crane by turning ON the starter switch, it blinks in green.

- **Receiving lamp**

When the receiver is received radio wave transmitted from the transmitter correctly, it blinks in green.

- **Interference lamp**

If it lights in red when power to the transmitter is turned OFF, it indicates that the receiver is receiving radio wave from outside.

If it lights in red when power to the transmitter is turned OFF, response time during radio control operation may become longer to a certain extent.

When radio control operation is initiated from the state where the power to transmitter is turned OFF, the "interference lamp" may light for a moment but it is not a fault.

- **Error lamp**

It blinks in red when something is wrong with the radio control transmitter/receiver.

It also blinks in red when batteries in the transmitter have been run out.



U-WAVE, RADIO REMOTE CONTROL DEVICE

◆ 3. Trouble inspection

If a trouble is found in the radio remote control device, check the following then contact the nearest UNIC authorized service shop.

Check if:

- ① Crane is controlled by manual levers.
- ② The "power lamp" on the transmitter lights. If it blinks or does not light, replace the batteries in the transmitter.
- ③ Switches and control levers on the transmitter make a correct operation.
- ④ The stay on the transmitter (antenna is built in) has not been broken or deformed.
- ⑤ The "mode indicator lamp" in the control box lights and the "power lamp" on the receiver blinks in green when power to the control box is turned ON.

If the "mode indicator lamp" blinks, refer to section "13. [9] Mode indicator" (on page 13-43).

If the "error lamp" on the receiver blinks in red, turn OFF the power once and turn it ON again (turn ON the starter switch again).

If blinking of "error lamp" persists, repair is needed as the radio remote control device is in failure.

U-WAVE, RADIO REMOTE CONTROL DEVICE

◆4. How to make an emergency stop

In case of emergency such as that the crane does not stop operation or the motor will not return to non rotating even if no crane operation has been made, depress the "EMERGENCY stop switch" on the switch panel.

This makes the crane and the motor to stop operation forcibly.

WARNING

★ After the emergency stop switch is pressed, "E13" is displayed on the display panel of the sub-control box and the crane is rendered inoperable. Release the button and re-energize the power for the crane.

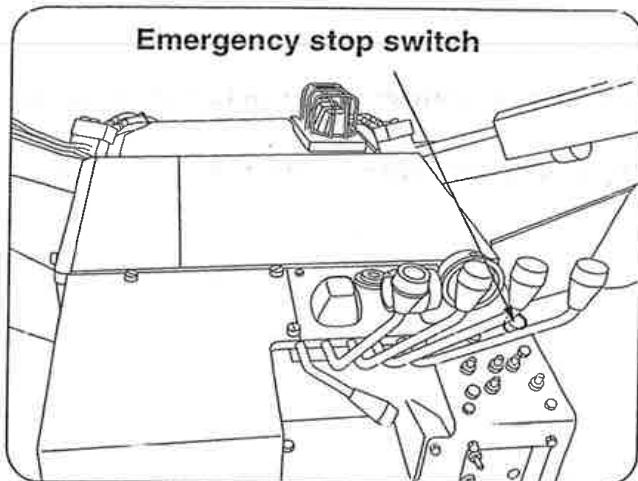

• How to make an emergency stop for the crane and reset it

Depress the "EMERGENCY stop switch" on the switch panel of crane body.

The switch is held pushed in allowing the motor to stop operation.

When the switch is held pushed in, the motor cannot be re-started.

Rotate the emergency stop switch clockwise in arrow direction to return to its original state to release the switch.

U-WAVE, RADIO REMOTE CONTROL DEVICE

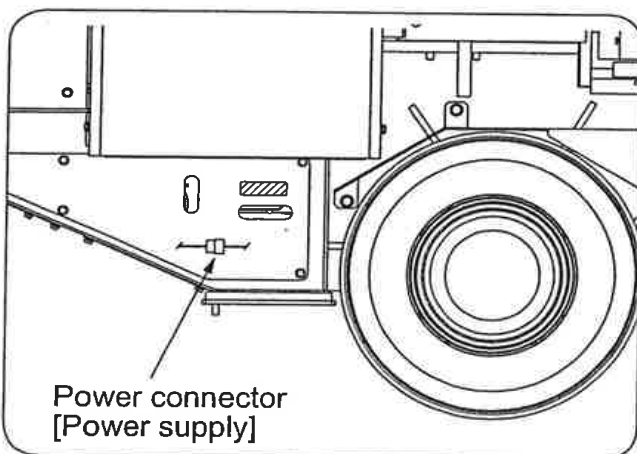
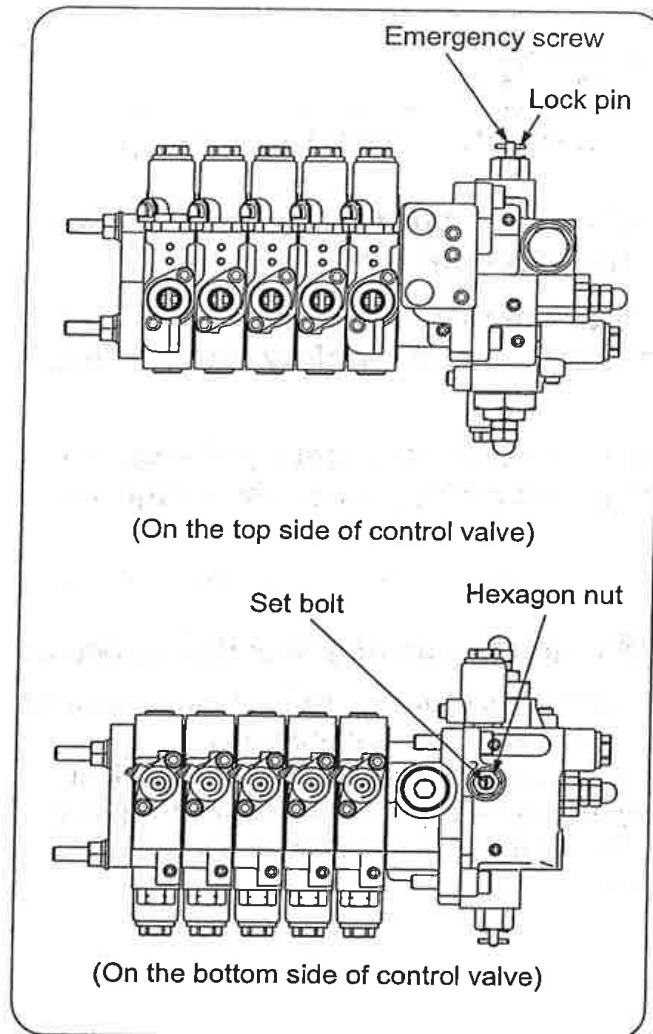

◆ 5. Operation in an emergency

If the crane fails to be operated either by radio remote control or by manual control, operate the crane by taking procedures as follows:

Procedure

- ① Remove the lock pin attached to the emergency screw and gently turn the emergency screw clockwise until tight. (Be careful that the screw may be damaged when tightening it with an excessive force.)
- ② Check that all the manual control levers are at their neutral positions. In case where a lever is caught in half-way, return it to its neutral position.
- ③ Remove the panel under the control valve to disconnect the power connector inside of it.
- ④ Loosen the hexagon nut attached to the lower part of the control valve and then tighten the locked set bolt until tight.
- ⑤ Rotate the motor under the idling mode.

Since this allows the crane to be operated, store the crane with manual control levers.

CAUTION

★ When the battery level is 10% or less, idling mode is not possible. Charging is necessary.

U-WAVE, RADIO REMOTE CONTROL DEVICE

⚠ CAUTION

★ Be sure to disconnect the power connector after the emergency screw has been tightened up.

If the power connector is disconnected without tightening up the emergency screw, the crane may make an abrupt movement.

★ If the power connector is disconnected, operate the crane carefully as the motor speed control, the voice message, and the safety device such as automatic stop will not function.

★ Since this is a temporary measure when in an emergency, be sure to repair the crane at an authorized UNIC service shop after the crane has been stored.

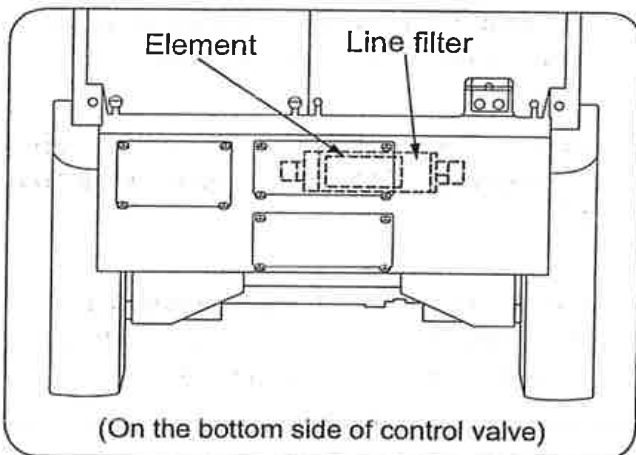

◆ 6. Replacement of line filter element

Replace the element inside of line filter after 1 year from the start of operation.

Be sure also to replace the element when the hydraulic pump is replaced and replace it after 1 year from the start of operation of the pump.



U-WAVE, RADIO REMOTE CONTROL DEVICE

9 Mode indicator lamp (Control box)

The "mode indicator lamp" is mounted in the control box indicating conditions of crane operation and troubles in detail.

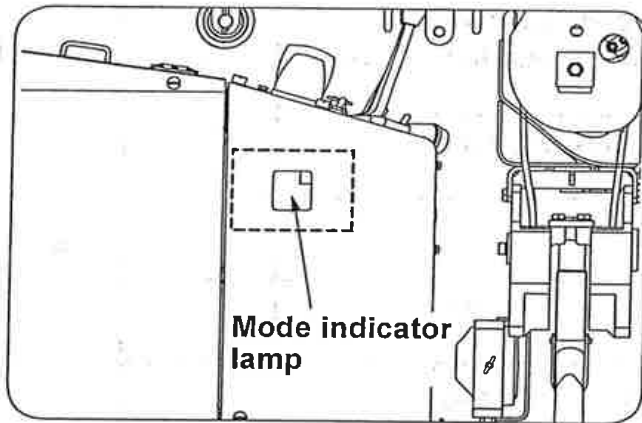

When the "mode indicator lamp" lights, the crane system is working normally.

When the "mode indicator lamp" blinks, the crane system is in a trouble or prohibited operation is being carried out.

◆ 1. Mode indication when crane is in normal operation

It indicates each operation mode and condition of the crane when it is normal.

Description of mode indication when it is in normal is as follows:

Mode indication when crane is in normal condition (lighting indication)

Mode	Mode description	Radio control operation mode	Manual operation mode	Priority
0F	Current control is on traveling mode. No operation other than traveling is possible either by manual control or by radio remote control.	×	×	1
00	Current control is on normal crane operation mode. Operation is possible either by manual control or by radio remote control.	○	×	9
01	Current control is on normal crane operation mode. Operation can only be carried out manually but not through radio remote control device.	×	○	9
04 05	Current operation is in outrigger radio control mode. Extension and retraction of outriggers can only be possible by manual control when in manual control mode or by radio remote control when in radio remote control mode.	○	×	5
	Operation other than the above is impossible either by manual or by radio remote control.	×	○	
06	Current control is on low temperature operation mode. Operation can be carried either by manual control or by radio remote control device.	○	○	8



U-WAVE, RADIO REMOTE CONTROL DEVICE

Mode	Mode description	Radio control operation mode	Manual operation mode	Priority
07.	Current control is on low temperature operation mode. Operation can be carried by manual control but not through radio remote control.	×	○	8
10	Hook hits against weight for over-winding alarm (over-wound condition).	—	—	7
13	During operation of storing hook.	—	—	6
14	Automatic stop for over-winding reset switch is being controlled	—	—	4
15	<ul style="list-style-type: none"> • Outriggers fail to touch the ground or overturn threshold alarm is actuated (URW095WBE). • Automatic stop of SLI system (URW295WBE). • Automatic stop of the boom storing. 	—	—	2
16	<ul style="list-style-type: none"> • Outriggers fail to be set up on the ground securely or overturn prediction alarm is actuated (URW095WBE). • SLI system alarm is actuated (URW295WBE). • Crane operating speed is slowly. 	—	—	3

● Remarks

Since priority is assigned for each mode description, it is to be indicated in the order of higher priority.

If the [.] (dot) is indicated on the bottom right of "mode indicator lamp", it means the "radio control OFF" mode.

Crane cannot be operated through radio control transmitter.

When operated on outrigger radio control mode, crane operation other than extension/retraction of outriggers cannot be carried out.

When the shock-less function has been cancelled, the letter on the left indicated in the mode indicator changes to [-].

Refer to page 13-23 for detail.



U-WAVE, RADIO REMOTE CONTROL DEVICE

◆2. Mode indication when crane is in trouble

When the "mode indicator lamp" is blinking figures larger than [42] (or [54] lights), the crane system is in trouble (system trouble indication).

If the system trouble indication is found on the "mode indicator lamp", confirm and follow the mode description on the table illustrated below:

If the crane becomes impossible to be operated, store the crane by following procedures described in section 13. 8 "◆5. Operation in an emergency" (on page 13-41), and ask an authorized UNIC service shop for repair.

Mode description when crane is in trouble (Blinking indication)

Mode	Mode description	Radio control operation mode	Manual operation mode
42~46	No operation is possible either by radio control or by manual control.	×	×
47~50	Turn OFF power once then turn it ON. If the trouble persists, ask an authorized UNIC service shop for repair. (Although it can be operated either by radio control or by manually, shock-less function returns to be "active".)	○	○
51~53	No radio control operation is possible.	×	○
54	Radio control receiver is not connected. Check that cable connector (located inside switch box) of receiver is securely connected. Check cable to receiver for damage and break.	×	○
55	Either "mode selector switch", "hook storing switch" or "radio control selector switch" in the control box is faulty. (Failed switch cannot be controlled but crane operation is possible.)	○	○
56	No operation is possible either by radio control or by manual control.	×	×
57	No operation is possible either by radio control or by manual control. Turn OFF power once then turn it ON again.	×	×
58	Radio control operation cannot be possible and motor speed control and safety devices will not function.	×	○



U-WAVE, RADIO REMOTE CONTROL DEVICE

Mode	Mode description	Radio control operation mode	Manual operation mode
60~65	Manual lever is not at its neutral position when power is turned ON. Do not operate the crane as it is carrying out system diagnosis for about 3 seconds after power has been turned ON. If this appears even when the crane has not been operated, ask an authorized UNIC service shop for repair.	×	×
66~69	Either one of "Outrigger control switches" in switch panel of the crane is in failure. (Failed switch cannot be controlled but crane operation is possible.)	○	○
70~74	Stop radio control operation to try controlling levers manually. Check that the manual control levers make a smooth movement and that any of levers will not interfere with anything. If indication fails to return to be normal, ask an authorized UNIC service shop for repair.	×	×
70~74	No radio control operation is possible.	×	○
80~85	No operation is possible either by radio control or by manual control.	×	×
99	Batteries of radio control transmitter are running out. Replace old batteries with new ones and turn OFF power once then turn it ON again.	○	○



U-WAVE, RADIO REMOTE CONTROL DEVICE

◆3. Mode indication when crane is mistakenly operated

When prohibited operation or combination of operation which may invites dangerous situations has been carried out, the "mode indicator lamp" will blink corresponding numbers (operation error indication).

When the operation error is indicated, the "mode indicator lamp" blinks showing corresponding numbers accordingly.

Confirm and follow the mode description concerned on the table illustrated below:

●Remarks

The operation error indication is not to indicate that the crane system is in trouble.

The error indication is to be reset when stopping the operation concerned.

Mode description when crane is mistakenly operated (Blinking indication)

Mode	Description of wrong operation	Measures to be taken
01	Radio remote control operation is carried out in manual control mode. ●Mode indicator lamp located on the top of cover will not be lit when in manual control mode.	Radio remote control cannot be carried out in manual control mode. When operating with radio remote controller, turn the selector switch located on the top of cover to radio remote control mode. ●Operation mode indicator lamp located on the top of cover will be lit when in radio remote control mode.
	Crane is being operated when in outrigger mode.	Crane cannot be operated when in outrigger control mode. When operating crane, turn the mode selector switch to "crane" to select crane mode.
04	Current control is on normal crane operation mode. Operation can only be carried out manually but not through radio remote control device.	Crane cannot be operated when in outrigger control mode. When operating crane, turn the mode selector switch to "crane" to select crane mode.
	Crane and outriggers are operated simultaneously.	When crane and outriggers are operated simultaneously, both operating functions are stopped automatically to avoid a risk. Stop the simultaneous operation once and carry out either one of operation.



U-WAVE, RADIO REMOTE CONTROL DEVICE

Mode	Description of wrong operation	Measures to be taken
06	"Low temperature operation mode" is being switched during crane operation.	In order to avoid a risk, "low temperature operation mode" cannot be switched during crane operation. Stop crane operation once to switch it to "low temperature operation mode". For switching "low temperature operation mode", refer to section 5 [6] "Switching to low temperature operation mode" (on page 13-32).
10	Either one of operation such as "boom Up", "hook Up", or "boom Extend" is being carried out while hook has hit against weight for over-winding alarm.	Detach hook from weight for over-winding alarm.



U-WAVE, RADIO REMOTE CONTROL DEVICE

10 Measures to be taken in an emergency

The "mode indicator lamp" is mounted in the control box indicating conditions of crane operation and troubles in detail.

Trouble	Possible cause	Measure to be taken
Crane fails to be operated by radio remote control device.	Batteries in transmitter have been run out or they are not loaded.	Replace batteries in transmitter.
Crane works just when a selector switch on transmitter is actuated.	Speed lever of radio control transmitter is faulty.	Repair radio control transmitter at a UNIC authorized service shop.
Crane works arbitrarily even when no controls have been made or a manual control lever has been shifted.	A solenoid valve of control valve is in failure.	Depress EMERGENCY stop switch to stop crane operation immediately. Gently turn the emergency screw clockwise until tight. (Pay attention that the screw may break if it is tightened with an excessive force.) Depress EMERGENCY stop switch again to reset emergency stop. Check that crane does not work when no controls have been made. Store crane with manual levers and ask a UNIC authorized service shop for replacement of faulty solenoid valve.

U-WAVE, RADIO REMOTE CONTROL DEVICE

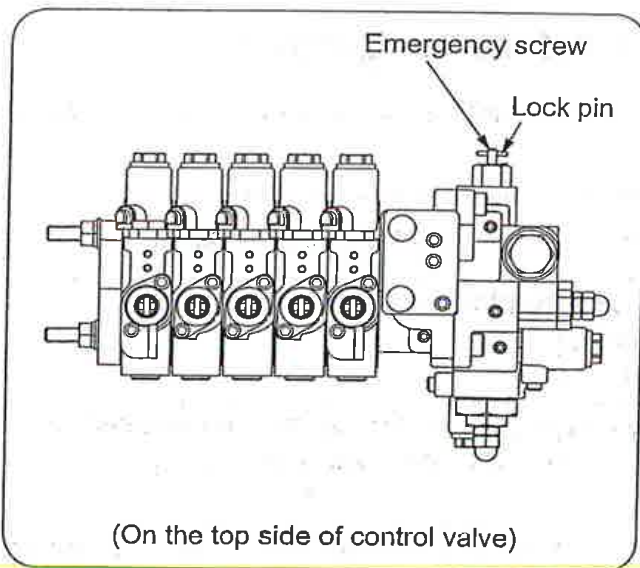

● Remarks

The emergency screw is fixed with a lock pin.
Remove the lock pin before turning the emergency screw.



14. MAINTENANCE AND INSPECTION OF CARRIER

WARNING

★ **Caution signboard**

Be sure to hang a “caution signboard” such as on control levers while either maintenance or inspection is being carried out, and do not try operating the crane.

★ Be sure to replace consumable items according to the replacement criteria.

Failure to observe the replacement as specified may cause a breakdown and warranty will not be given even if it is within the period to be applied.

★ When a part needs to be replaced or anything abnormal is found, contact a UNIC service shop for consultation or for inspection or ask repair as soon as possible.



MAINTENANCE AND INSPECTION OF CARRIER

1 *Inspection before operation*

! WARNING

- ★ When you perform an inspection, unplug the connector for the battery to avoid being shocked.
Do not touch the electrical components for 10 minutes or more as electricity is built up inside the equipment shortly after unplugging it.
- ★ Be sure to stop the motor, and store the boom and the outriggers before carrying out maintenance and inspection.
- ★ A fire source such as smoking cigarette in mouth is strictly prohibited.
- ★ Do not start maintenance and inspection immediately after the motor has been stopped.
Carry it out after the motor and the heated parts have been cooled down.
- ★ Do not plug/unplug any connectors or perform wiring work and inspection with wet hands as you could be shocked.

In order to secure safety in crane operation and to improve working efficiency, be sure to inspect each part of the carrier according to the table as follows:

Device	Servicing item	Device	Servicing item
Battery	Damaged wires	Hydraulic oil tank	Oil leakage, Oil quantity, Filling up
	Battery electrolytic solution level check	Interlock for crane-travel lever	Function
	Amount of electrolyte solution	Steering lever Traveling lever	Slack, Travel
	Electrolyte specific gravity	Wheel	Loose bolt
Motor	Corrosion	Solid rubber tire	Crack, Damage
	Loose bolt, Broken bolt Strange noise Abnormal vibration Abnormal smell	Frame Steering	Bend, Crack, Deformation Loose nut, Oil leakage

! CAUTION

- ★ Perform monthly and annual inspection according to “Voluntary inspection table” in the warranty which is provided separately.
- ★ Keep the crane in good condition so that it will be always ready for normal operation.

MAINTENANCE AND INSPECTION OF CARRIER

◆ 1. Inspection of Battery

! WARNING

- ★ To perform battery maintenance, make sure the electric power unit is stopped and the battery plug is disconnected.
- ★ The hydrogen gas produced from the battery fluid is flammable. When you want to service the battery, never do so near flame.
- ★ The battery is high voltage. When performing installation, maintenance and inspection on it, if you come in contact with its conductive parts, you might sustain burns due to electric shock.
- ★ The battery fluid contains sulfuric acid components. If any of it gets into your eyes, or on your skin or clothes it may cause visual impairment and burns. Always wear protective gear such as safety glasses and rubber gloves when handling the battery fluid. If the battery fluid comes in contact with your skin or clothes, rinse it off immediately with plenty of water. Above all, if it gets into your eyes consult a physician.
- ★ If electrolyte gets into your mouth or is swallowed, immediately gargle with plenty of drinking water several times. Then, drink a large amount of drinking water or milk. Afterwards, seek immediate medical attention. Ingestion of electrolyte can cause chemical burns.
- ★ Do not clean the battery surface or connections with a feather duster or dry cloth because the battery produces flammable gas and the static electricity may ignite the gas causing an explosion.
- ★ Do not wipe the battery with static electricity-producing cloth because the battery produces flammable gas and the static electricity may ignite the gas causing an explosion.

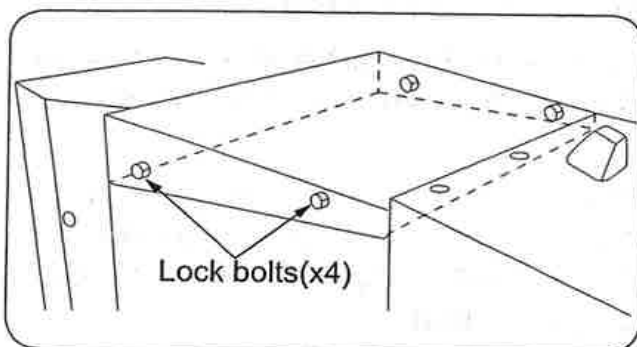

Make space to remove the battery case by extending the outriggers and raising the boom.

Unfasten the lock bolts (x4) on the battery case cover to remove it.

MAINTENANCE AND INSPECTION OF CARRIER

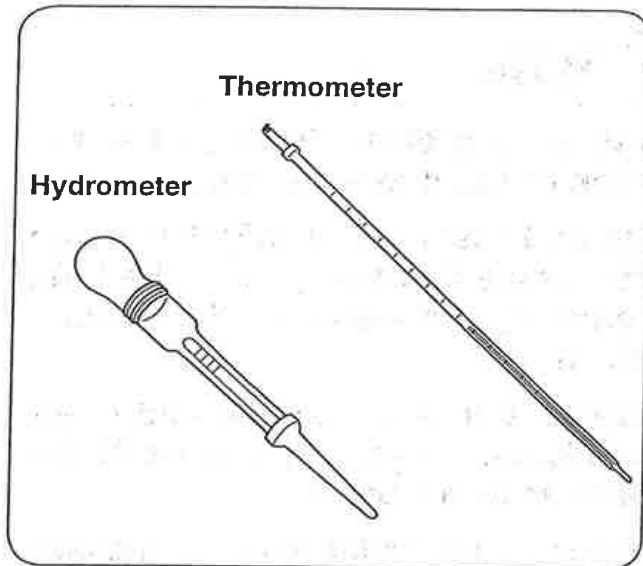

◆ **1-2 Specific gravity inspection**

- Check the specific gravity of the electrolyte solution one time a month. Inspect whether the proper charge is being executed, and for any difference in performance across each cell of the battery.
- Measure initially [i.e., when fully charged, approx. 1.280/20°C] and check that the values are normal.
- Measure the liquid temperature with a thermometer and convert the specific gravity measurement in terms of the specific gravity at 20°C. The hydrometer formula is as follows.
- $D_{20} = D_t + 0.0007 (t-20)$
- D_{20} : Specific gravity when converted at 20°C
- D_t : Specific gravity measurement
- t : Temperature of the electrolyte solution (°C) at the time of measurement
- If the specific gravity has reached 1.150 (20°C) or less, always charge the battery until it reaches a specific gravity of 1.280 (20°C).
- Specific gravity when fully (total) charged
1.280 (20°C)

MAINTENANCE AND INSPECTION OF CARRIER

◆2. Battery cleaning

CAUTION

- ★ If dirt or foreign matter is sticking to the top of the battery or to the connections, it might cause an explosion or fire due to leakage.
- ★ Do not wash the battery while it is still installed. It might damage the crane. Remove the battery from the crane and then, close the fluid injection cap to prevent water from entering the inside of the battery. Finally, dry the battery well and reinstall it.
- ★ Do not clean the battery with benzene, thinner, gasoline and other organic solvents, detergents and chemicals. Organic solvents might damage the battery and cause electrolyte to leak from it.
- ★ Do not expose the battery to rain water or sea water. Getting the battery wet might cause a fire or damage the battery.



Wipe the battery clean of dirt and foreign matter using a well rung damp cloth. Always keep the area around the battery clean and dry. Do not use high-pressure washing on the battery as the water from the washing might infiltrate the electrical system and cause a malfunction.



MAINTENANCE AND INSPECTION OF CARRIER

⚠ CAUTION

- ★ **Traveling on damaged rim(s) or tire(s), or worn tire(s) is very dangerous as it might cause the crane to slide. If any damage is noted, contact your designated Unic service facility so they can inspect and repair the damage.**
- ★ **Do not run the crane over lying rocks or stones with sharp edges.**
- ★ **Do not change direction where there is a difference in ground level.**
- ★ **Do not operate the crane on a ground being heated to the temperature of more than 60°C.**
- ★ **Do not stain the rubber tire with oils such as fuel, hydraulic oil, grease, and the other oil.**
- ★ **Do not operate the crane at a place where salt content is abundant.**
- ★ **When storing the crane for long period of time, store it indoors where it will not be exposed to the ray of the sun or to the rain directly.**

◆ 3. Tire and rim inspection

Inspect for any tire wear, tire damage and bending of the rim(s). Change the tire before the tire pattern (groove) is worn too far down.

◆ 4. Inspecting the steering

Stop the crane in a safe area. Move the steering lever to the left and right, and check for any problems when turning the steering fully to the left and right.

◆ 5. Inspecting the motor and inverter

Turn ON the power to the crane. Using the idling mode, run the motor and inverter and check for any strange noises.

* Refer to section 10-6 about the idling mode.

MAINTENANCE AND INSPECTION OF CARRIER

◆ 6. Check hydraulic oil tank for oil level / Filling up

! WARNING

★ Since temperature on the hydraulic oil tank surface is too high immediately after operation, remove the cap of the filling port after the temperature has gone down.

! CAUTION

★ Replace hydraulic oil for the first time after 3 months of operation, and every year or every 500 hours of operation thereafter.

★ Clean up the suction strainer and the return-filter once a year.

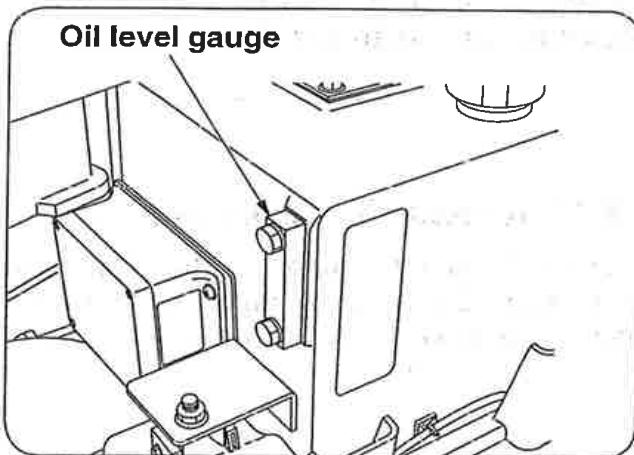

- Park the crane on a flat ground to stop the motor.
- Check the oil quantity at the oil level gauge located in front of oil tank.
Capacity of hydraulic oil tank: 27 liters

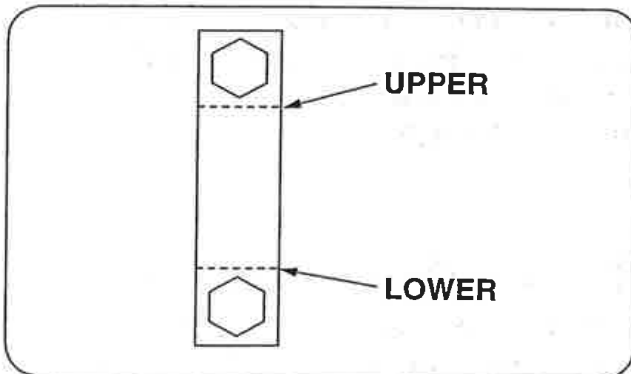

- A proper quantity of hydraulic oil is somewhere between "UPPER" and "LOWER" limits as illustrated in the figure.

- If oil level is found below the "LOWER" limit, remove the cover to the tank and remove the cap to fill it up with a specified oil.

MAINTENANCE AND INSPECTION OF CARRIER

2 Inspection and Maintenance which is to be carried out every 250 hours or 3 months

- ◆ 1. Check oil quantity in the reduction gears of traveling motor/Filling up (Change oil every 1,000 hours)

! WARNING

★ Do not rush to work as each section of traveling devices is heated to a high temperature immediately after the crane operation.

Work after temperature of traveling devices has cooled down.

★ Pressure may be remained inside of the reduction gears of traveling motor.

Unfasten the filling port plug by 2~3 turns slowly to release the internal pressure and then remove the plug.

An abrupt removal of the plug may cause the plug to pop out or the oil to spurt out which is dangerous.

Do not turn your body or face toward the plug.

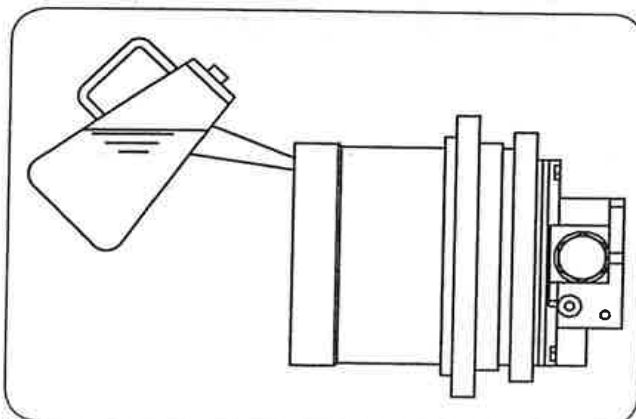
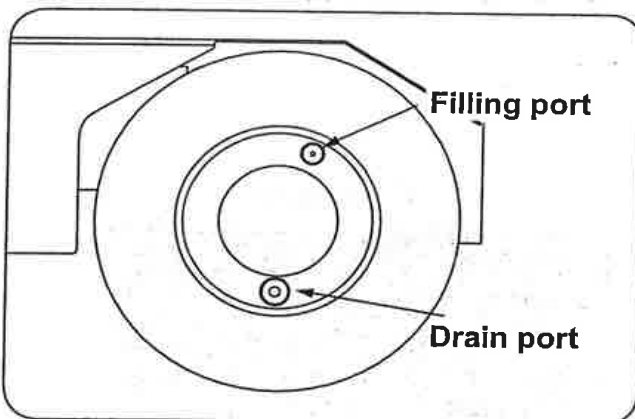

- 1** Park the crane on a flat ground.
- 2** Position 2 (two) plugs at the end of reduction gears of traveling motor as illustrated in the figure, "position for inspection", and stop the motor.
- 3** Unfasten the filling port plug slowly to bleed air.
- 4** Remove the filling port plug and oil quantity is correct if oil flows out of the filling port. If oil quantity is insufficient, fill it with the oil specified.
- 5** Check the sealing of each plug, replace it with new seal if it is found damaged.
- 6** Put the plug on the filling port and tighten it.

MAINTENANCE AND INSPECTION OF CARRIER

3 Storage

! WARNING

★ Stop the motor and thoroughly remove dirt and dust stuck on the carrier body.

In particular, be sure to remove the dust stuck to the battery, electric wiring, and the members directly affected by motor heat may cause a fire.

★ In order to prevent those who are not in charge such as children from access to the crane, cover the crane or store it in a storage house.

Cover the crane after all the heated parts in the crane body have been cooled down, otherwise it may cause a fire.

★ Shift travel lever and steering lever at its neutral position.

★ Avoid storing the crane more than 3 months at a place where it is likely to be exposed to the direct sun light as the tire made of rubber.

★ Disconnect a plug of battery cable if the crane is to be stored for a long period of time.

Failure to do this may cause a fire due to short-circuited such as by biting of a rat.

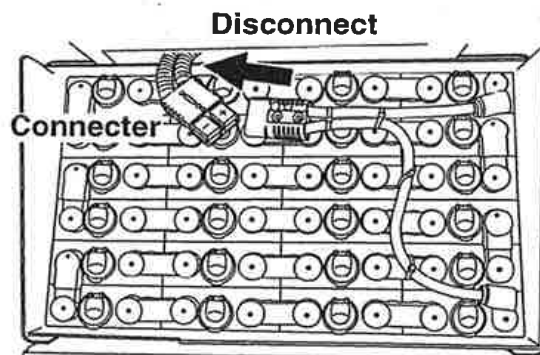



MAINTENANCE AND INSPECTION OF CARRIER

4 *Fitting safety covers*

! WARNING

★ Be sure to fit the safety covers removed during inspection and maintenance where they were fitted originally. Otherwise, it is very dangerous because uncovered rotating members and heated parts may cause injury.



15. MAINTENANCE AND INSPECTION OF CRANE

WARNING

★ **Caution signboard**

Be sure to hang a “caution signboard” such as on control levers while either maintenance or inspection is being carried out, and do not try operating the crane.

★ **Be sure to replace consumable items according to the replacement criteria.**

Failure to observe the replacement as specified may cause a breakdown and warranty will not be given even if it is within the period to be applied.

★ **When a part needs to be replaced or anything abnormal is found, contact a UNIC service shop for consultation or for ask inspection or repair as soon as possible.**



MAINTENANCE AND INSPECTION OF CRANE

1 Inspection before operation

In order to secure safe operation and improve working efficiency, be sure to inspect daily each part of the crane according to the table as follows:

Device	Servicing item	Device	Servicing item	Device	Servicing item
Pump	Tightness of each mounting Oil leakage Unusual noise	Hook	Rotation of hook Function of retaining mechanism	Frame	Mounting of crane body Cracks Tightness of bolts Missing bolt
Hydraulic oil tank	Oil level Oil leakage	Wire rope	Damage Condition of rope-end	Slinging implements	Items necessary for crane operation are provided
Outriggers	Natural descent Function Control lever return Deformation Damage Oil leakage Cracks	Overwinding alarm	Function Alarm sound	Automatic storing device for hook	Function of automatic stop and storing operation
Hoisting winch	Function Control lever return Braking function Irregular winding	Interlock for crane-travel lever	Check that crane will not actuate on traveling, and wheelcrane will not travel on travel lever return and on crane operation.	Automatic stop for leaving minimum wire rope	Further unwinding stops automatically when remaining wire rope on the drum comes to 3 turns.
Slewing device	Function Control lever return Oil leakage	Load meter	Oil leakage Function	Turn over prevention device (URW-095WBE)	Refer to page 9-12 Inspection before starting operation Daily inspection Trouble inspection Alarm inspection Inspection for automatic stop Check wiring for damage Check sensor mounting for tightness
Derricking boom	Function Control lever return Oil leakage Mounting of foot-pin	Warning horn	Function		
Telescoping boom	Function Control lever return Oil leakage Deformation Cracks Mounting of fixing pin	Piping, Hydraulic hose	Oil leakage Damage		

CAUTION

★ Perform monthly and annual inspection according to “Voluntary inspection table” in the warranty which is provided separately.

★ Keep the crane in good condition so that it will be always ready for normal operation.

MAINTENANCE AND INSPECTION OF CRANE

2 *Cleaning*

Keep the crane clean at any time.

Sands and fine dusts may cause an abnormal wear .

Do not wash the crane by splashing highly pressurized water to prevent it from entering into the electric system by which may cause malfunction of the crane.

3 *Inspection of bolts mounting slewing bearings*

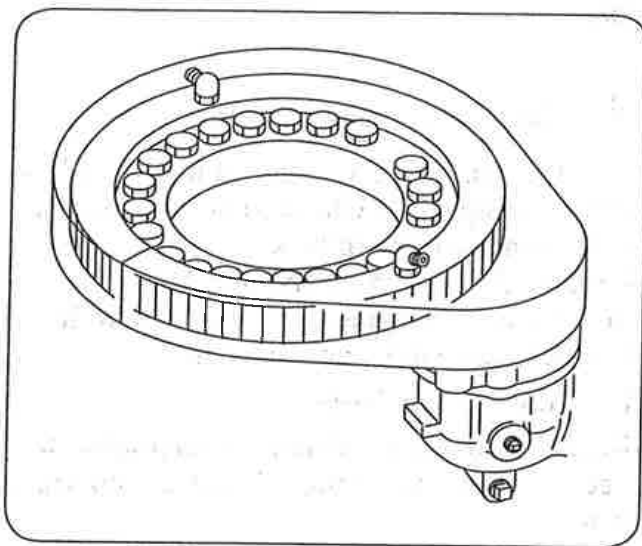

When the slewing device makes an unusual noise while operating or traveling the crane, or when a gap is created on the mounting surface, contact a UNIC authorized service shop for inspection and/ for repair.



CAUTION

★ Break of the bolts mounting slewing bearings may invite an accident such as overturn and destruction of the crane.

Check the mounting bolts (outer ring side) for tightness once every 6 months.

MAINTENANCE AND INSPECTION OF CRANE

4 Replacement of wire rope (for winding-up)



Wire rope is an expendable article and it will be damaged and its strand wires are broken to allow it to be thinner through a long period of operation. Replace the rope according to following criteria.

◆ 1. Replacement criteria

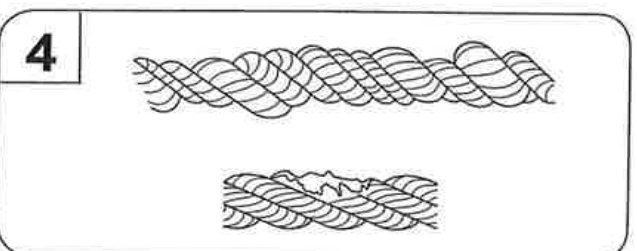
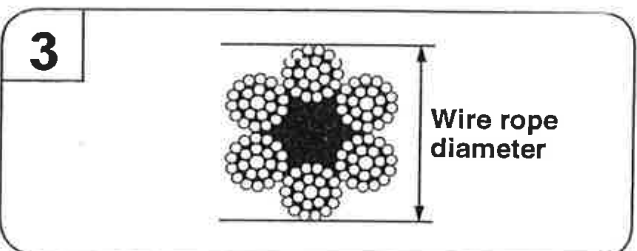
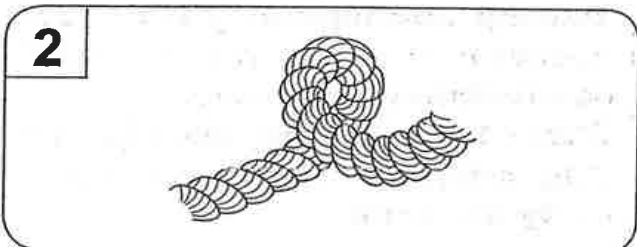
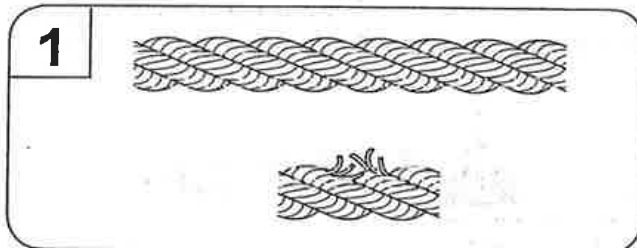

1. A rope in which amount of broken strand wires (except filler wires) comes to more than 10% within a pitch of twist.

Replace the wire ropes intended for use with this crane if 13 pieces of strand wire have been broken within a pitch of twist.

2. A rope being kinked.

3. A rope from which its diameter has decreased by more than 7% of the nominal diameter.

For example, if wire rope with a nominal diameter of 8mm is used, replace it when the diameter becomes 7.5mm.

Refer to the section 17, MAJOR SPECIFICATIONS, for length and construction of the wire rope for winding-up.

4. A rope which has been deformed and/or corroded excessively.

★ Be sure to replace a wire rope when it comes under the criteria, item 1 through 4, illustrated above.

CAUTION

★ Wear leather gloves when replacing wire ropes.

MAINTENANCE AND INSPECTION OF CRANE

◆ **2. How to replace wire ropes**

1. Refer to the figure in the left for how to hook the wire ropes for winding -up and for where the weight for overwinding alarm is to be mounted.

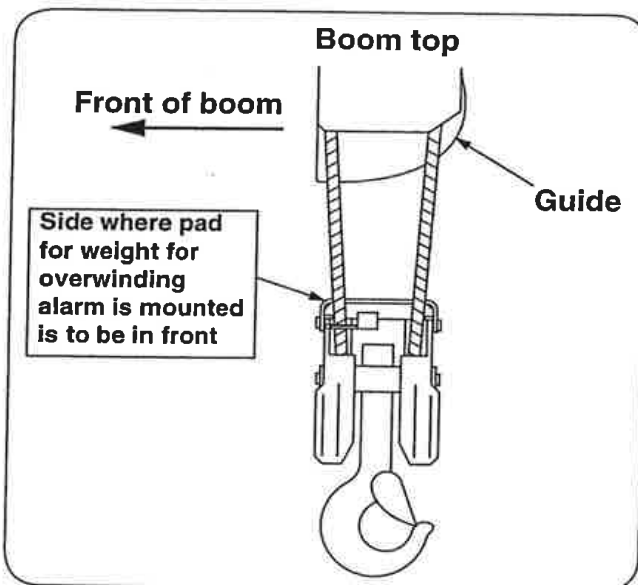
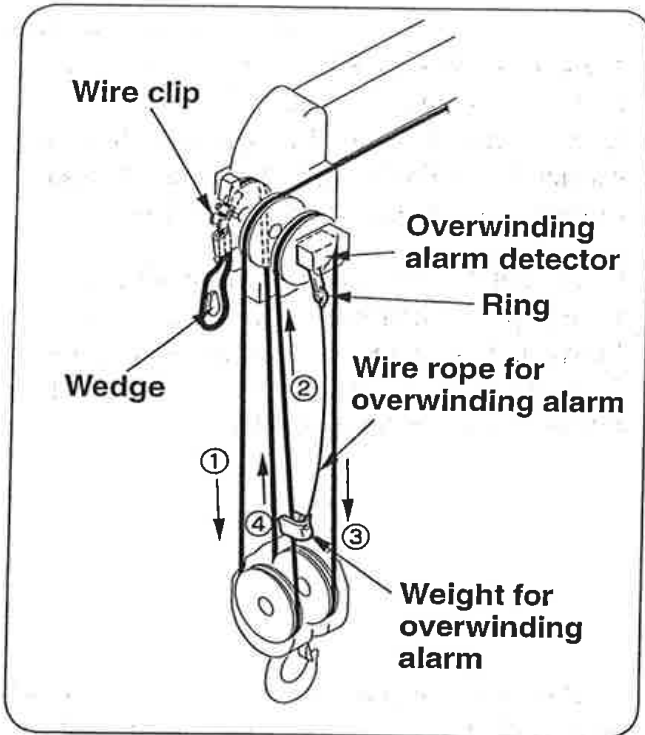

Refer to the figure in the left for how to attach the hook.

MAINTENANCE AND INSPECTION OF CRANE

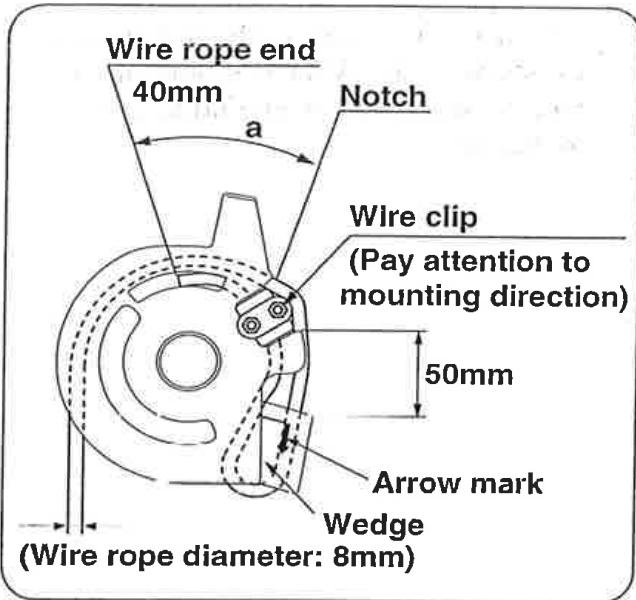

2. How to fix wire rope end.

① When passing the wire rope end through the wire socket, be sure to pass it as indicated by the arrow mark on the socket.

If it is passed from the opposite direction, service life of wire rope becomes shorter as the wire rope is kept bent all the time.

② Do not forget to mount the wedge and the wire clip as illustrated in the figure in the left. Leave the wire rope end to allow a distance from the notch to the rope end by more than 40mm as illustrated in the figure as "a"

③ Pass the pin through with the wire socket held with your hand and tighten it with the bolt securely.

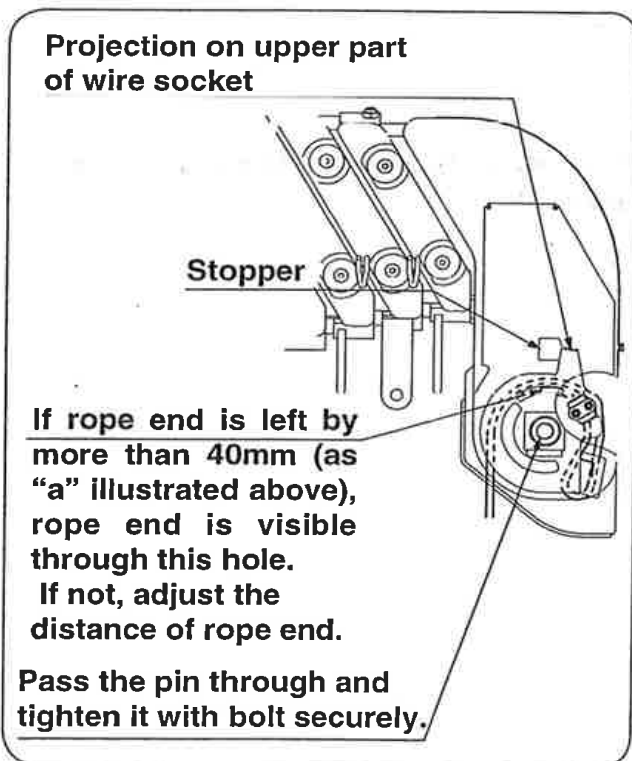

MAINTENANCE AND INSPECTION OF CRANE

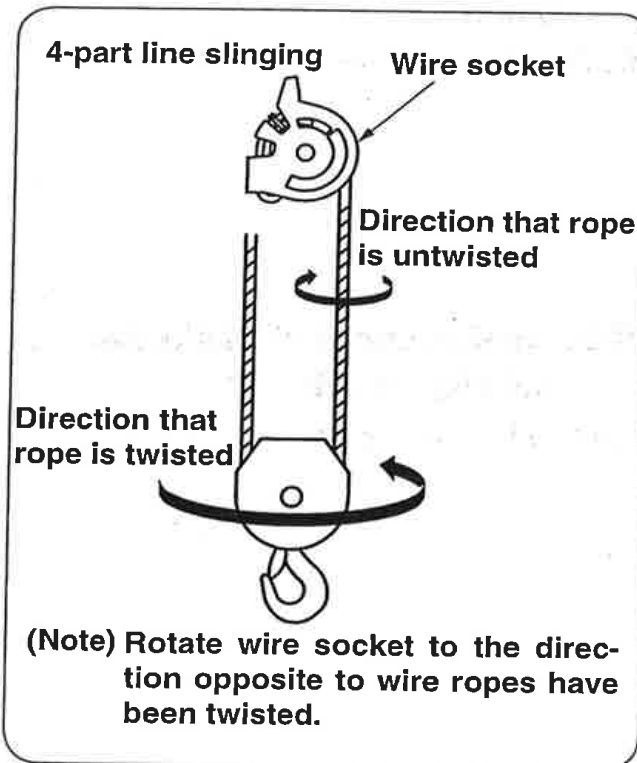
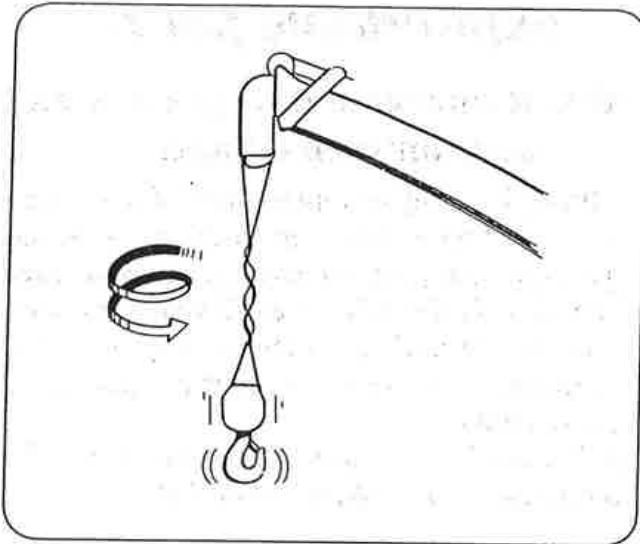

3. How to correct twisted wire ropes

Wire ropes tend to turn in untwisting direction when they are under tension.

If two or more wire ropes are hooked together, they tend to be twisted particularly while they are new.

The twist will decrease as the ropes are getting fit to the crane.

If wire ropes are twisted, correct them as follows:

1. Unload the hook.
2. Extend the boom fully.
3. Raise the boom to an angle of approximately 65°.
4. Unwind the hook until it comes close to the ground.
5. Check how many turns the wire rope has been twisted.
6. Wind up the hook and retract the boom to be on a stored condition.
7. Remove the wire socket and turn the socket in the untwisting direction by as many turns as the wire ropes have been twisted multiplied by the number of wire ropes being hooked. However, remember that the wire socket may be turned up to 4 turns at a time.
8. Attach the wire socket and repeat winding up and down the rope 2 or 3 times between both extremes. Then, check if twist of the wire ropes is corrected. If they remain twisted, repeat the procedures shown above.

MAINTENANCE AND INSPECTION OF CRANE

5 Replacement of expendable parts

◆ 1. Replacement of gaskets and seals for each cylinder

Although timing of replacement of a part varies according to how frequently the crane has been operated, replace gaskets and seals used in each cylinder after every 3 years of operation (period during which crane has not been operated is included) in order to operate the crane safely.

Ask a local UNIC authorized service shop for replacement of gaskets and/or seals.

◆ 2. Replacement of sliding plate of boom

Replace it every 3 years.

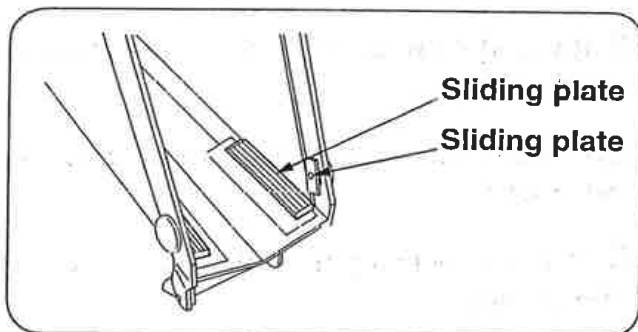

◆ 3. Replacement of brake shoe of hoisting winch

Replace it every 3 years.

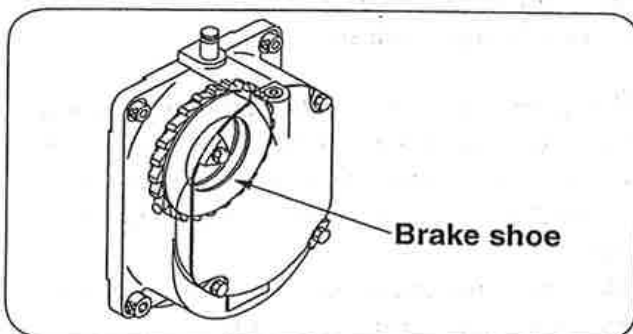



16. LUBRICATION TO CARRIER

WARNING

- ★ Be sure to stop the motor, and store the boom and the outriggers before carrying out filling/replacing lubricant.
- ★ A fire source such as smoking cigarette in mouth is strictly prohibited.
- ★ Do not rush to start maintenance and inspection as the motor and the members close to the motor is heated to a high temperature immediately after the motor has been stopped.
- ★ When you perform an inspection, unplug the connector for the battery to avoid being shocked.

1 *Precaution when carrying out lubrication*

Lubricate according to "Lubrication chart" and keep the following instructions in mind when carrying out lubrication.

1. Clean filling ports and grease nipples thoroughly before carrying out lubrication.
2. Always supply new lubricant and prevent dusts from entering inside.
3. When supplying grease into each grease nipple, be sure to inject it until old grease is forced out of it.

CAUTION

★ In order to ensure smooth operation of each part of the crane, minimum wear, and longer service life, be sure to supply lubricant as well as hydraulic oil which is indispensable to drive hydraulic equipment.

★ Warranty will not be given, even if it is within the period to be applied, for failure to observe the replacement of lubricant as specified.



LUBRICATION TO CARRIER

2 List of recommended lubricant

- ◆ 1. Use the recommended grease for lubrication as below.

Chassis grease

Use NLGI No. 2 grade for most temperatures.

Use NLGI No. 1 grade for extremely low temperatures.

- ◆ 2. Hydraulic oil is the same as the oil used in the crane.

- ◆ 3. Use the gear oils for the reduction gears of traveling motor as below:

Classification	Depending on atmospheric temperature						
	-30	-20	-10	0	10	20	30
Rating to be applied							
Engine oil							
Diesel engine oil of CD class	SAE30						

SIHELL : DONAX TT or TD

CALTEX : RPM TRACTOR HYDRAULIC FLUID

CHEVRON : TRACTOR HYDRAULIC FLUID

TEXACO : TDH OIL

MOBIL : MOBILAND SUPER UNIVERSAL.

- ◆ 4. Use the purified water to the battery replenisher.

LUBRICATION TO CARRIER

3 *Filling oil and lubrication chart*

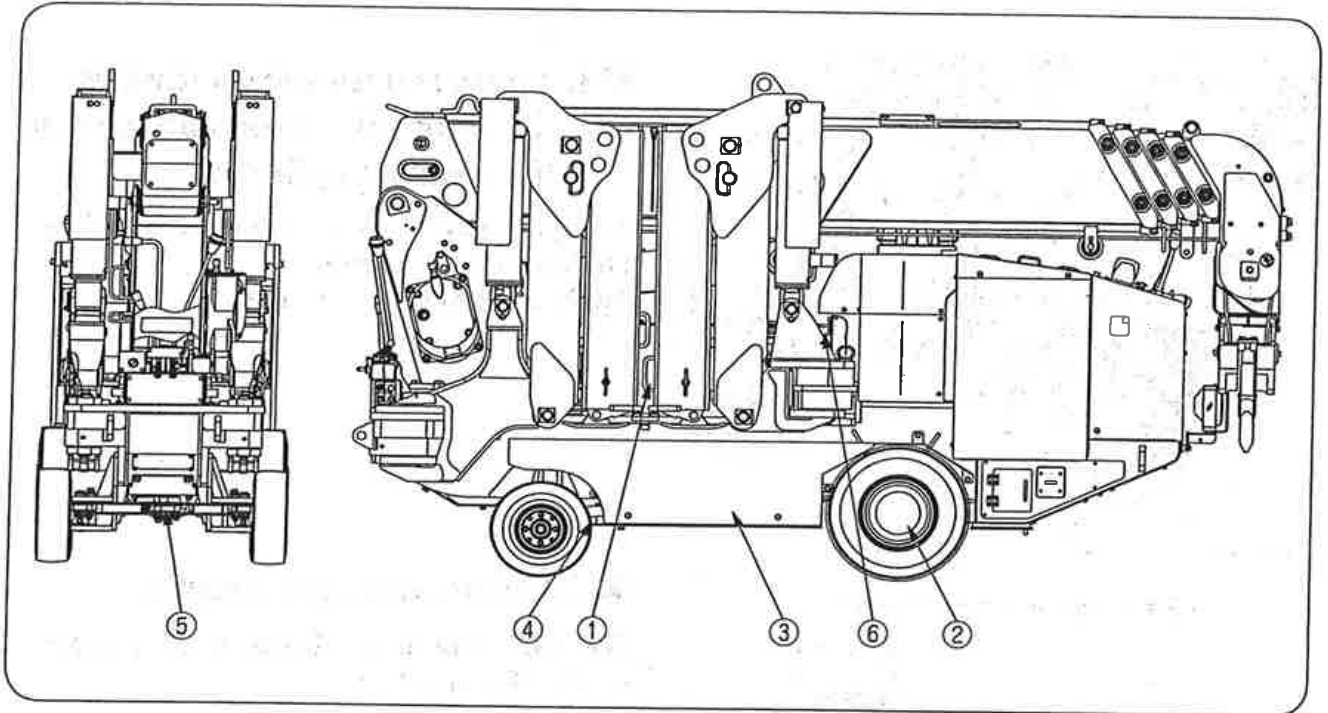

Service interval	Where to lubricate	No. of part	Lubricant	Tool
Initial: Replace after 3 months After : Replace once a year or every 500 hours	①Hydraulic oil tank (27 liters)	1	Hydraulic oil	
Replace every 1000 hours	②Reduction gears of traveling motor (0.33 liters)	2 (Right/Left)	Diesel engine oil	
Daily	③Front support pin of steering cylinder	1	Chassis grease	Grease pump
	④Rear support pin of steering cylinder	1	Chassis grease	Grease pump
	⑤Steering link (Each pin of the link and shaft connects the left and right tires)	6	Chassis grease	Grease pump
Replace every 6 month	⑥Coupling input shaft and hydraulic pump input shaft	1	Chassis grease	Manual application

LUBRICATION TO CARRIER

4 Lubrication

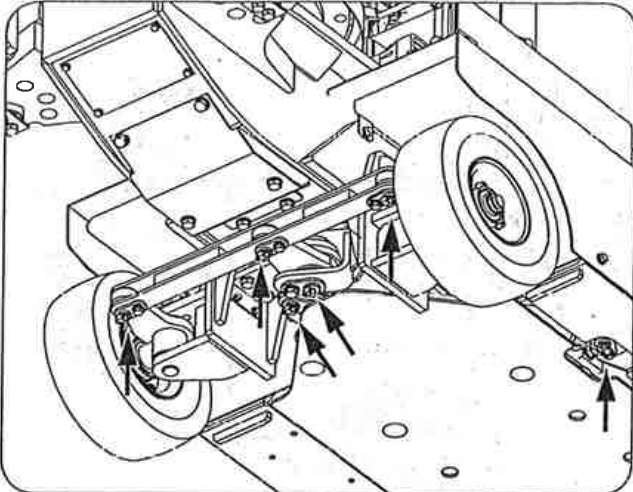

- ◆ **1. There is a nipple on the boss of the lubrication rod end around the steering cylinder.**

Always apply lubricant as insufficient lubrication can cause failure.
Apply lubricant once per day.

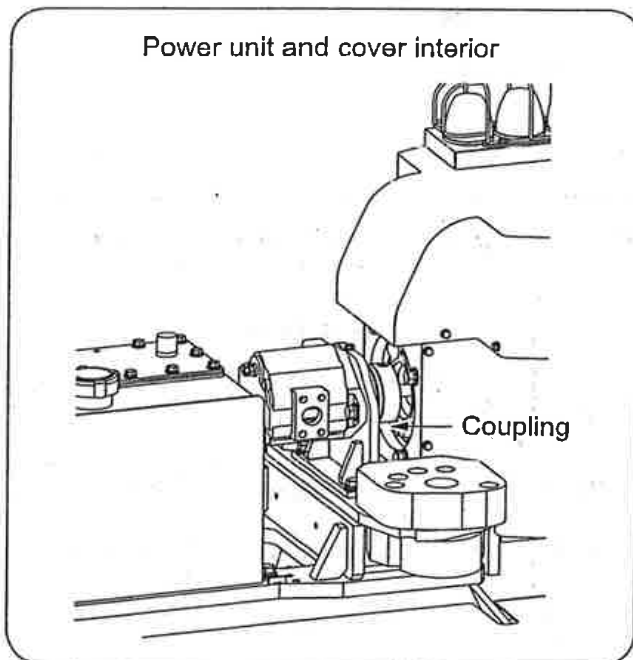

- ◆ **2. Lubricating the coupling**

We recommend the following lubrication greases for this device.

Chassis grease No.1

(Consistency 310 to 340)

Application point: Coupling input shaft

Hydraulic pump input shaft



CAUTION

★ The lubrication grease for the coupling should be applied when performing the periodic inspection every six months.

17. LUBRICATION TO CRANE

! WARNING

- ★ When you perform an inspection, unplug the connector for the battery to avoid being shocked.
 - ★ Do not carry out maintenance and inspection while temperature of hydraulic oil is still high.
 - ★ Be sure to stop the motor to carry out lubrication.
 - ★ Temperature of both hydraulic and gear oils is very high immediately after crane operation so that accumulated high pressure still remains inside.
- Uncapping the filling port, draining oil, and replacing filter while oil temperature is high may allow the hydraulic and/or gear oils to spout out from which a scald may result.

1 Precaution when carrying out lubrication

Lubricate according to "Lubrication chart" and keep the following instructions in mind when carrying out lubrication.

1. Clean filling ports and grease nipples thoroughly before carrying out lubrication.
2. Always supply new lubricant and prevent dusts from entering inside.
3. When supplying grease into each grease nipple, be sure to inject it until old grease is forced out of it.

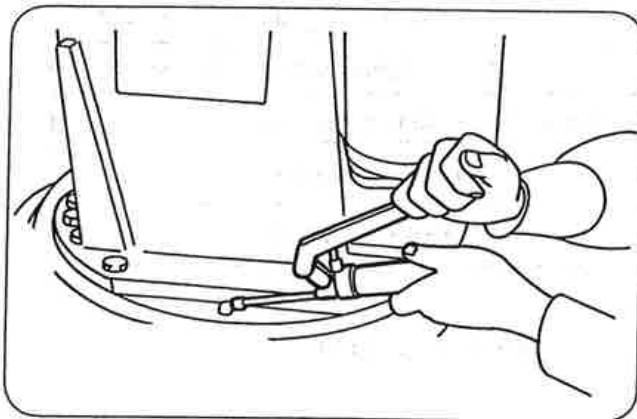

! CAUTION

★ In order to ensure smooth operation of each part of the crane, minimum wear, and longer service life, be sure to supply lubricant as well as hydraulic oil which is indispensable to drive hydraulic equipment.

★ Warranty will not be given, even if it is within the period to be applied, for failure to observe the replacement of lubricant as specified.



LUBRICATION TO CRANE

2 List of recommended lubricant

◆ 1. List of recommended lubricants

★ Use the UNIC genuine hydraulic oils listed below as hydraulic oil for the crane.

Use industrial-type hydraulic oil

ISO VG 32 for temperatures below 0°C.

Petroleum Maker	Brand
	ISO VG 32
EXXON MOBIL	Mobil DTE 24
CHEVRON	Rando Oil HD ISO 32
SHELL	Shell Tellus Oil 32

★ Use the recommended lubricants listed below as gear oil for lubrication.

Aplication	Petroleum Maker	Brand
Reducer for winch	EXXON MOBIL	Mobil Delvac Super DH-2 15W-40
	SHELL	Shell Rimula R3 X 15W-40
Reducer for slewing gear	Use API service GL-4 gear oils. (Refer to the followings)	
	CHEVRON	Thuban GL4 90
	SHELL	Shell Spirax EP 90

★ Use the recommended greases listed below as grease for lubrication.

(a) Chassis grease

Use NLGI No. 2 grade for most temperatures.

Use NLGI No. 1 grade for extremely low temperatures.

(b) Molybdenum grease

Use NLGI No. 2 grade.

Petroleum Maker	Brand
EXXON MOBIL	Mobilgrease CM-P
CHEVRON	Moly greases EP 2 (Texaco Molytex EP 2)
SHELL	Retinax grease EPX 2 (Retinax grease AM)



LUBRICATION TO CRANE

3 Lubrication chart

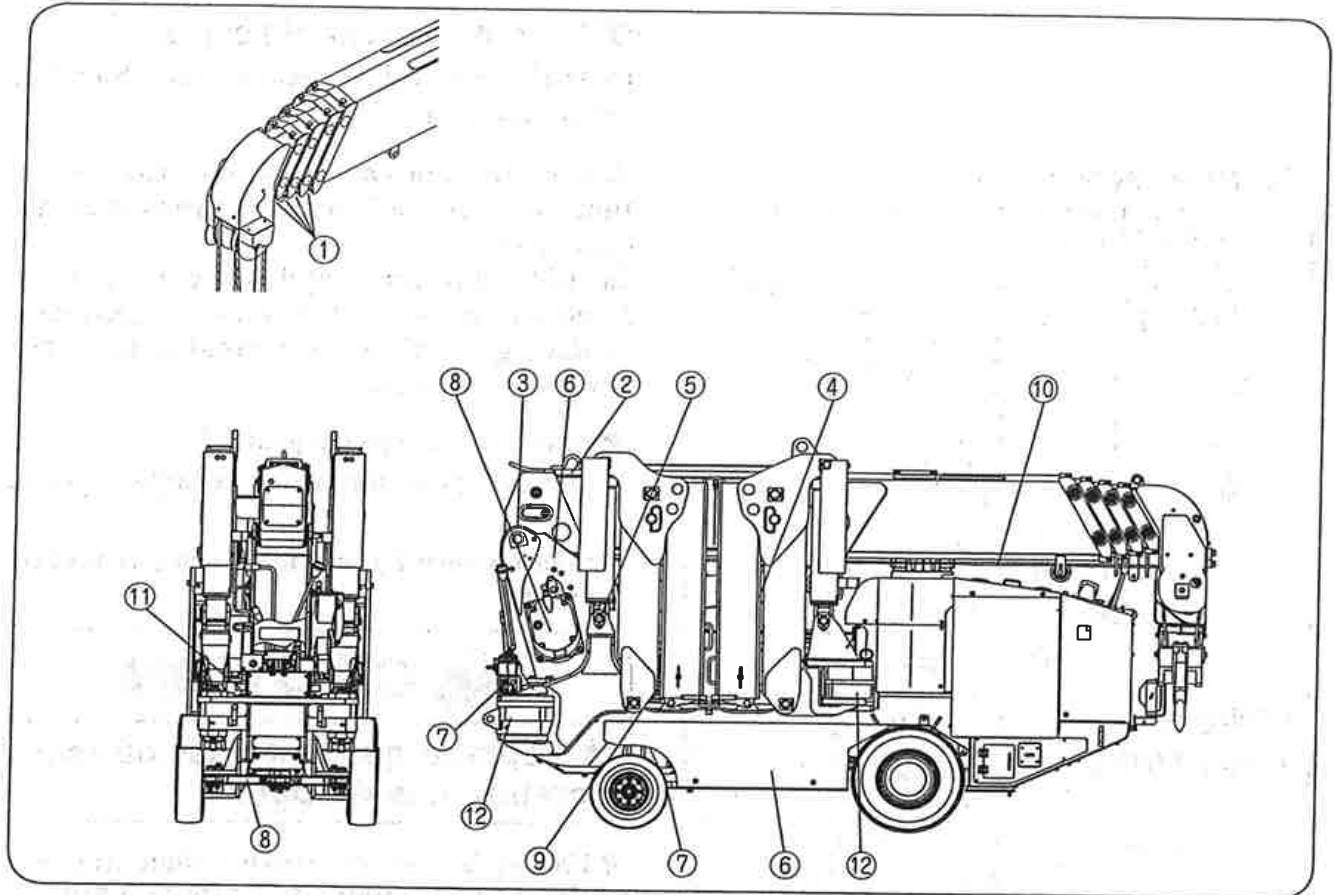

Service interval	Where to lubricate	No. of part	Lubricant	Tool
Daily	① Boom slide plate (Underside & side face of boom sections ②, ③, ④, and ⑤) For 5-section boom	4	Molybdenum grease	Manual application
	② Boom slide plate (Upper side of boom section ①)	4	Molybdenum grease	Grease pump
	③ Boom foot pin	1	Chassis grease	Grease pump
	④ Upper support pin of derrick cylinder	1	Chassis grease	Grease pump
	⑤ Lower support pin of derrick cylinder	1	Chassis grease	Grease pump
Weekly	⑥ Winch drum gears	1	Chassis grease	Grease pump
	⑦ Slewing gears	1	Chassis grease	Manual application
Monthly	⑧ Winch reduction gears (Approx. 1.0 liter)	1	Gear oil	
	⑨ Slewing reduction gears (Approx. 0.3 liters)	1	Gear oil	
	⑩ Wire rope	1	Rope grease	Spray gun
	⑪ Slewing bearings	2	Chassis grease	Grease pump
	⑫ Outrigger fulcrum pin	4	Chassis grease	Grease pump

LUBRICATION TO CRANE

4 Lubrication

◆ 1. Replacement of gear oil

(Winch reduction gears and Slewing reduction gears)

★ Air enters in and out of the gear case so that dirt and moisture are brought in the gear case.

In addition, since hydraulic equipment gradually wears to produce worn particles, replace gear oil after 6 months from the start of operation.

★ Afterward, replace gear oil:

- Once a year for winch reduction gears, and
- Once every 2 years for slewing reduction gears.

⚠ CAUTION

★ Replace gear oil after oil temperature has dropped.

★ Fill up the oil for winch reduction gears until oil level comes to halfway between upper limit and lower limit on the oil level gauge (oil quantity: approx. 1.0 liter).

★ Fill up the oil for slewing reduction gear until oil level comes to halfway between upper limit and lower limit on the oil level gauge (oil quantity: approx. 0.3 liters).

In order to check oil level, insert the level gauge until it just touches the oil level port (not screwing it in).

Winch reduction gears

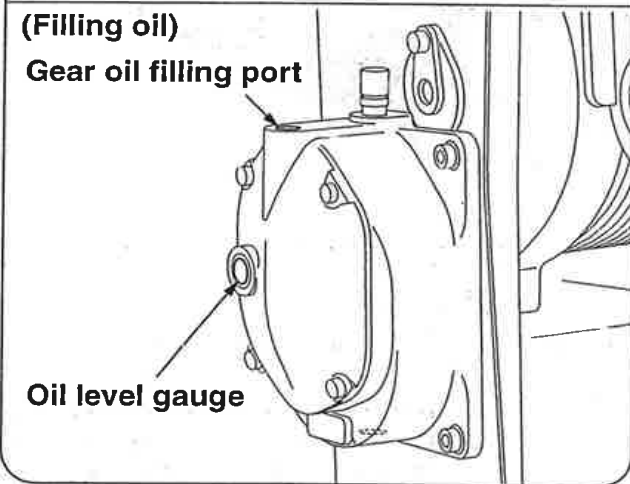
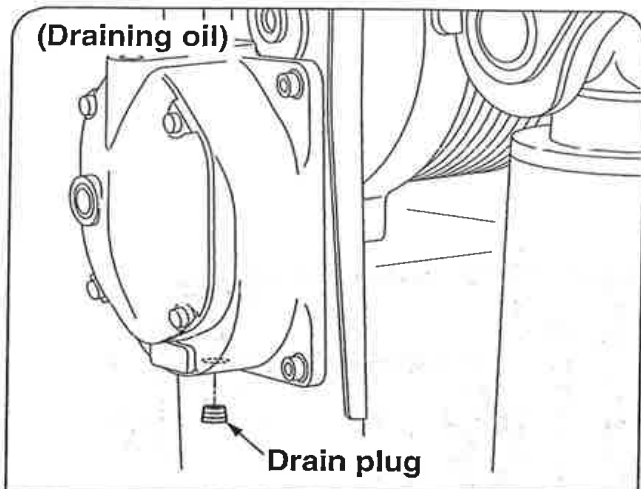

Slewing reduction gears

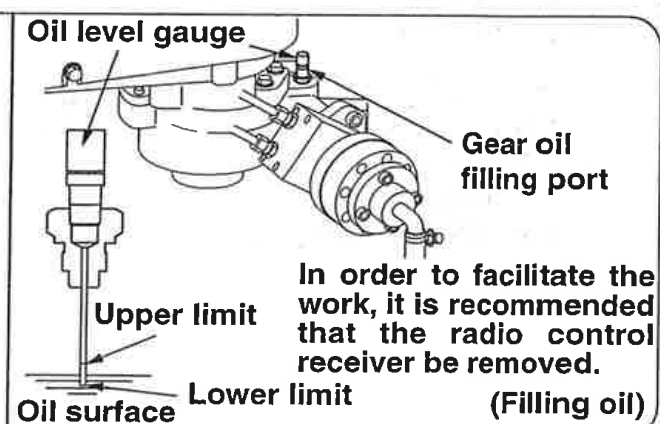
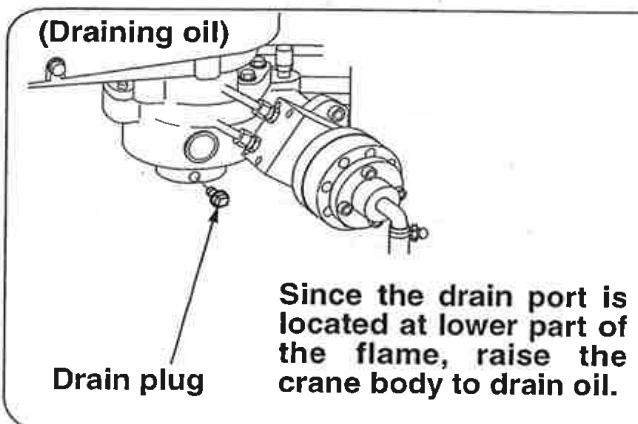

LUBRICATION TO CRANE

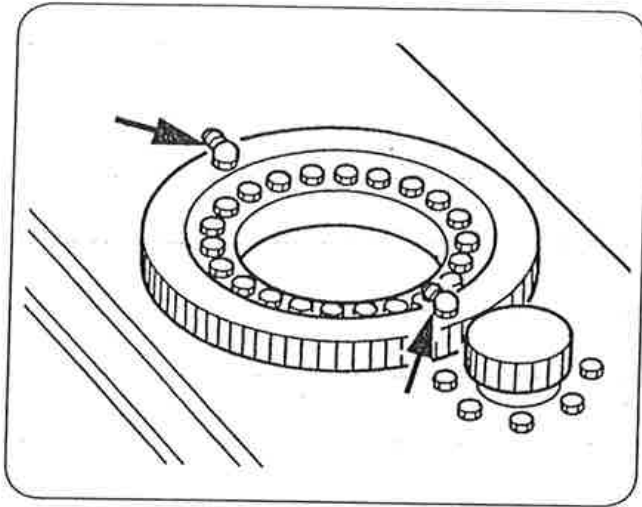

◆ **2. Lubrication to slewing bearings**

The crane employs ball bearings as the slewing bearing.

Be sure to lubricate the bearings as insufficient lubrication may cause it to make unusual noise.

Grease the nipples while slewing the boom once a month for moderate operation, and once a week for heavy-duty operation.



18. MAJOR SPECIFICATIONS

1 URW295WBE (5-section boom)

(Speed indicated in the table below is at oil temperature range of 45~55°C, operating with no-load, and at rated pump discharge.)

Major specifications

Model		URW295WBE (5-section boom)
Crane capacity (maximum lifting load)		2.93t×1.4m (With outriggers extended fully)
Maximum lift above ground (Hook)		Approx. 8.9mm
Boom to be extended to:		2.53m ~ 4.075m ~ 5.61m ~ 7.13m ~ 8.65m
Maximum working radius		8.41m
Speed of winding-up (Rope speed)		Standard: 32m/min (At 4th layer on the drum)
		Highspeed: 36.4m/min (At 4th layer on the drum)
Hoisting speed of hook		Standard: 7.0m/min (At 4th layer on the drum)
		Highspeed: 9.1m/min (At 4th layer on the drum)
Extending speed of boom		Standard: 6.12m/31sec
		Highspeed: 6.12m/23sec
Raising speed of boom		Standard: 0° ~ 78°/17sec
		Highspeed: 0° ~ 78°/12sec
Slewing speed		1.5r.p.m.
Slewing range		360°(continuous)
Hoisting rope	Construction	IWRC 6×WS (26) Class B (Breaking load: 42.4kN{4320kgf})
	Diameter×length	8mm×54.0m
Outrigger		Direct pushing by double acting hydraulic cylinder (directly connected to hydraulic automatic locking device)
Hydraulic pump	Rated pressure	Crane: 20.6MPa(210kgf/cm ²) Travel: 21.6MPa(220kgf/cm ²)
	Rated discharge	Standard: 18l/min
		Highspeed: 26.4l/min
Rated rotation	Standard: Approx. 1500rpm	
	Highspeed: Approx. 2200rpm	
Hydraulic oil tank Capacity		27 L



MAJOR SPECIFICATIONS (URW295WBE)

Equipment and construction

Model	URW295WBE (5-section boom)
Boom telescoping	Boom: 5-section, Hexagonal box beam
	Telescoped by direct pushing of hydraulic cylinder and by wire rope (With hydraulic automatic locking device) (2nd & 3rd sections: sequential actuation, 4th & 5th sections: simultaneous actuation)
Boom derricking	Direct pushing by hydraulic cylinder (With hydraulic automatic locking device)
Hoisting	Hydraulic motor: Axial plunger type
	Reduction gears: Spur-gear reduction
	Brake: Automatic mechanical brake
Slewing	Hydraulic motor: Trochoid type (With hydraulic automatic locking device)
	Reduction gears: Worm-gear+Spur-gear reduction (Supported by ball bearings)
	Brake: Worm self-lock
Hydraulic pump	Variable delivery piston pump
Hooking capacity	2.9t Number of slinging rope: 4
Safety devices	Pressure relief valve for hydraulic circuit
	Hydraulic automatic lock (Counterbalance valves and pilot-operated-check valves)
	Automatic stop for overwinding
	Overwinding alarm
	Alarm buzzer
	Hook safety latch
	Interlock for crane-travel lever and outriggers
Level	
Weight	Approx. 2380kg



MAJOR SPECIFICATIONS(URW295WBE)

Crawling device

Model	URW295WBE (5-section boom)
Travel model	Wheel type (tire type)
Tire, wheel	Front wheel 4.00-8(Rim3.00D-8) Rear wheel 3.5-5(Rim3.00SP-5)
Pressure of ground contact	Front wheel 671KPa(6.84+kgf/cm ²) Rear wheel 637KPa(6.50 kgf/cm ²)
Speed	Forward/Backward Standard: 0 ~ 1.7km/h)
	Forward/Backward Highspeed: 0 ~ 2.6km/h)
Steering angle	L50°、R50°
Hill-climbing ability	15°
Motor	Motor model: 14310-13950-71(TOYOTA INDUSTRIES CO.LTD.)
	Power supply voltage: DC 48 V
	Rated output : Standard 4.0 KW : Highspeed 6.0 KW
	Rated RPM : Standard 1500 rpm : Highspeed 2200 rpm
Traveling	Independently driven by hydraulic power
Parking brake	Disc brake with hydraulic motor built-in
Battery	Model:VCI-225 (DC48 V-225 Ah)
	Continuous operating time : Standard Approx. 270 min : Highspeed Approx. 240 min
	Charging time : 80% Approx. 5 hour : 100% Approx. 10 hour



MAJOR SPECIFICATIONS(Radio remote control device)

3 Major specification (Radio remote control device)

Model / Radio frequency	RC-500HA-AUS / 434 MHz band								
Transmission output	10 mW								
Frequency selection	Auto-scanning system								
Range of radio wave	100m min. (when in good conditions)								
System structure	Combined system of manual and radio remote control operation								
Controls (functions operated through radio control transmitter)	Selector switches : Boom :Raise/Lower (Hook RELEASE) Outrigger ④ Ret/Ext Hook :Hoist/Lower (Shock-less ON/OFF) Outrigger ③ Ret/Ext Boom telescoping:Extend/Retract Outrigger ② Ret/Ext Slewing :C.C.W./C.W. Outrigger ① Ret/Ext Store hook :Storage								
	Speed selector switch: Switching to mode of : High/Medium/Low speed Mode switch :Switching each function by combination of selector switch Horn switch :Alarm/Start Speed lever :Both hydraulic control and motor speed control								
Power supply	Crane: Battery on mounting vehicle (DC 12V) Transmitter: a size AAA battery: 4 pieces								
Power consumption	Crane operating single function at maximum speed: Approx. 50W, 120W max. (including control box) Transmitter (service life with alkaline batteries): 20 hours min.								
Voice messages	<table style="width:100%; border:none;"> <tr> <td style="width:50%;">"Crane mode"</td> <td style="width:50%;">"Remote control ready"</td> </tr> <tr> <td>"Outrigger mode, Outrigger's moving"</td> <td>"Stop winch up"</td> </tr> <tr> <td>"Secure lifting hook"</td> <td>"Low transmitter battery"</td> </tr> <tr> <td>"Service remote control"</td> <td>"Change control mode"</td> </tr> </table>	"Crane mode"	"Remote control ready"	"Outrigger mode, Outrigger's moving"	"Stop winch up"	"Secure lifting hook"	"Low transmitter battery"	"Service remote control"	"Change control mode"
"Crane mode"	"Remote control ready"								
"Outrigger mode, Outrigger's moving"	"Stop winch up"								
"Secure lifting hook"	"Low transmitter battery"								
"Service remote control"	"Change control mode"								
Operating temperature range	-20°C~+60°C								
Storing temperature range	-30°C~+75°C								
Weight of remote controller	700g (including batteries)								

★ The radio remote control device employs a unique data transmission system and an ID (identification) code is assigned to each equipment.

Therefore, the crane will not be worked by radio wave radiated from other radio equipment.

★ About auto-scanning system :

Auto-scanning system is a system that changes the current frequency to other frequencies automatically to avoid radio interference when a similar radio wave is being radiated nearby.





FURUKAWA UNIC CORPORATION

HEAD OFFICE : Nihonbashi nishikawa Bldg, 5-3, Nihonbashi
1-chome, Chuo-ku, Tokyo 103-0027, Japan